

# Site Preparation Guide

**hp 9000 rp7420**

**Third Edition**



**Manufacturing Part Number : A7025-96019**

**October 2006**

Printed in the U.S.A.

© Copyright 1979-2006 Hewlett-Packard Development Company, L.P.

---

## Legal Notices

© Copyright 2006 Hewlett-Packard Development Company, L.P.

The information contained herein is subject to change without notice.

The only warranties for HP products and services are set forth in the express warranty statements accompanying such products and services. Nothing herein should be construed as constituting an additional warranty. HP shall not be liable for technical or editorial errors or omissions contained herein.

### Revision History

First Edition Initial release. December 2003. P/N was A7025-96004

Second Edition Minor edits. June 2004.

Third Edition Minor edits. Updated system power requirements in Chapter 1. October 2006.

**1. System Specifications**

Dimensions and Weights . . . . .	2
Electrical Specifications . . . . .	3
Grounding . . . . .	3
Circuit Breaker . . . . .	3
System AC Power Specifications . . . . .	3
Environmental Specifications . . . . .	5
Temperature and Humidity . . . . .	5
Cooling . . . . .	5
Typical Power Dissipation and Cooling . . . . .	6
Acoustic Noise Specification . . . . .	6
Airflow . . . . .	7
System Requirements Summary . . . . .	8
Power Consumption and Air Conditioning . . . . .	8
Weight . . . . .	8

**2. General Site Preparation Guidelines**

Electrical Factors . . . . .	12
Computer Room Safety . . . . .	12
Power Consumption . . . . .	13
Electrical Load Requirements (Circuit Breaker Sizing) . . . . .	13
Power Quality . . . . .	13
Distribution Hardware . . . . .	14
Grounding Systems . . . . .	15
System Installation Guidelines . . . . .	18
Environmental Elements . . . . .	19
Computer Room Preparation . . . . .	19
Cooling Requirements . . . . .	19
Humidity Level . . . . .	22
Dust and Pollution Control . . . . .	22
Metallic Particle Contamination . . . . .	23
Electrostatic Discharge Prevention . . . . .	23
Acoustics . . . . .	24
Facility Characteristics . . . . .	25
Floor Loading . . . . .	25
Windows . . . . .	27
Space Requirements . . . . .	28
Delivery Space Requirements . . . . .	28
Operational Space Requirements . . . . .	28
Equipment Footprint Templates . . . . .	30
Computer Room Layout Plan . . . . .	31
Power Plug Configuration . . . . .	33
Conversion Factors and Formulas . . . . .	37
Example of an Installation Schedule . . . . .	38
Sample Site Inspection Checklist . . . . .	39
Delivery Survey . . . . .	42

---

# Contents

**Site Preparation Glossary.....45**

**Index .....49**

Table 1-1. HP 9000 rp7420 Server Server Dimensions and Weights . . . . .	2
Table 1-2. HP 9000 rp7420 Server Component Weights . . . . .	2
Table 1-3. Power Cords. . . . .	3
Table 1-4. AC Power Specifications . . . . .	4
Table 1-5. Typical HP 9000 rp7420 Server Configurations . . . . .	6
Table 1-6. Example Weight Summary. . . . .	8
Table 1-7. Weight Summary . . . . .	8
Table 2-1. Computer Room Environment . . . . .	21
Table 2-2. Effect of Humidity on ESD Charge Levels . . . . .	23
Table 2-3. Floor Loading Term Definitions . . . . .	25
Table 2-4. Typical Raised Floor Specifications . . . . .	26
Table 2-5. Customer and HP Information. . . . .	39
Table 2-6. Site Inspection Checklist . . . . .	39



Figure 1-1. Airflow Diagram . . . . .	7
Figure 2-1. Raised Floor Ground System . . . . .	17
Figure 2-2. Cabinet Dimensions . . . . .	28
Figure 2-3. Footprint . . . . .	29
Figure 2-4. Planning Grid . . . . .	32
Figure 2-5. C20 Male Receptacle (at power supply). . . . .	33
Figure 2-6. C19 Female Plug (on one end of the power cord) . . . . .	33
Figure 2-7. Unterminated Plug . . . . .	34
Figure 2-8. L6-20 Plug . . . . .	34
Figure 2-9. IEC 309 Plug . . . . .	34
Figure 2-10. CEE 7-7 Plug . . . . .	34
Figure 2-11. L6-30 Plug . . . . .	35
Figure 2-12. NEMA 5-20P Plug . . . . .	35
Figure 2-13. ISI 32 Plug . . . . .	35
Figure 2-14. GB 1002 Plug . . . . .	36
Figure 2-15. L6-20 Power Cable . . . . .	36
Figure 2-16. Delivery Survey (Part 1) . . . . .	43
Figure 2-17. Delivery Survey (Part 2) . . . . .	44





---

# **1 System Specifications**

This chapter describes the basic server configuration and its physical specifications and requirements.

---

## Dimensions and Weights

This section provides dimensions and weights of the system components.

**Table 1-1 HP 9000 rp7420 Server Server Dimensions and Weights**

	<b>Stand-alone</b>	<b>Packaged</b>
Height	17.3 in / 43.9 cm	35.75 in / 90.8 cm
Width	17.5 in / 44.4 cm	28.0 in / 71.1 cm
Depth	30.0 in / 76.2 cm	28.38 in / 72.0 cm
Weight - Pounds (kilograms)	220 lb / 100 kg	N/A

The shipping box, pallet, ramp, and container adds approximately 50 lb to the total system weight. The size and number of miscellaneous pallets will be determined by the equipment ordered.

**Table 1-2 HP 9000 rp7420 Server Component Weights**

<b>Quantity</b>	<b>Description</b>	<b>Weight (lb/kg)</b>
1 or 2	Cell board	27.80 lb / 12.61 kg
1	System backplane	12 lb (estimate) / 5.44 kg (estimate)
1	PCI backplane	20.4 lb / 9.25 kg
2	Bulk power supply	18 lb / 8.2 kg
1	Mass storage backplane	1 lb / 0.45 kg
2	PCI DC-to-DC converters	5 lb / 2.27 kg

## Electrical Specifications

This section provides electrical specifications for HP 9000 rp7420 Server.

### Grounding

The site building shall provide a safety ground for each AC service entrance to all cabinets.

Install a protective earthing conductor that is identical in size, insulation material, and thickness to the branch-circuit supply conductors. The PE conductor must be green with yellow stripes. The earthing conductor must be connected from the unit to the building installation earth or, if supplied by a separately derived system, at the supply transformer or motor-generator set grounding point.

### Circuit Breaker

The Marked Electrical for the HP 9000 rp7420 Server is 12 amps. The recommended circuit breaker size is 20 amps for North America. For countries outside North America, consult your local electrical authority having jurisdiction for the recommended circuit breaker size.

The HP 9000 rp7420 Server contains four C20 power receptacles located at the bottom rear bulkhead. A minimum of two power cords must be used to maintain normal operation of the HP 9000 rp7420 Server. A second set of two cords can be added to improve system availability by protecting, for example, against power source failures or accidentally tripped circuit breakers. The HP 9000 rp7420 Server can receive AC input from two different AC power sources.

## System AC Power Specifications

### Power Cords

Table 1-3 lists the various power cables available for use with a HP 9000 rp7420 Server system. Each power cord is 15 feet (4.5 meters) in length with a IEC 60320-1 C19 female connector attached to one end.

**Table 1-3 Power Cords**

Part Number	Description	Where Used
8120-6895	Stripped end, 240 volt	International–Other
8120-6897	Male IEC309, 240 volt	International–Europe
8121-0070	Male GB-1002, 240 volts	China
8120-6903	Male NEMA L6-20, 240 volt	North America/Japan

### System Power Specifications

Table 1-4 lists the AC power requirements for an HP 9000 rp7420 Server. This table provides information to help determine the amount of AC power needed for your computer room.

**Table 1-4 AC Power Specifications**

Requirements	Value	Comments
Nominal input voltage	200/208/220/230/240 (VAC rms)	
Frequency range (minimum – maximum)	50 – 60 (Hz)	
Number of phases	1	
Maximum input current	12 amps	Per line cord
Maximum inrush current	30 A peak for 15 ms	Per line cord
Power factor correction	>0.98 >0.95	At all loads of 50% –100% of supply rating At all loads Of 25% – 50% of supply rating
Ground leakage current (mA)	<3.0 (ma)	Per line cord

Power Required (50 - 60 Hz)	Watts	VA	Comments
Maximum Theoretical Power	3000	3060	See #1 below
Marked Electrical Power	---	2640	12A @ 220 VAC, see note #2
Typical Maximum Power	1975	2015	See note #3

1. “Maximum theoretical power” is used to describe input power at the AC input. It is expressed in Watts and Volt-Amps to take into account power factor correction. The calculated sum is the maximum worst case power consumption for every subsystem in the server. This number will not be exceeded by a properly functioning server for any combination of hardware and software.
2. “Marked electrical power” is the input power measured at the AC input expressed in Volt-Amps. The marked electrical power is the rating given on the chassis label and represents the input power required for facility AC power planning and wiring requirements. This number represents the expected maximum power consumption for the server based on the power rating of the bulk power supplies. This number can safely be used to size AC circuits and breakers for the system.
3. “Typical maximum power” is the input power measured at the AC input expressed in Watts and Volt-Amps, and the measured maximum worst case power consumption. This number represents the largest power consumption for the server under laboratory conditions, using aggressive software applications designed specifically to work the system at maximum loads and power consumption.

## Environmental Specifications

This section provides the environmental, power dissipation, noise emission, and airflow specifications for the HP 9000 rp7420 Server.

### Temperature and Humidity

The cabinet is actively cooled using forced convection in a Class C1-modified environment. The recommended humidity for a Class C1 server is 40-55%.

### Operating Environment

The system is designed to run continuously and meet reliability goals in an ambient temperature of 5° to 35° C at sea level. The maximum allowable temperature is derated 1° C per 1000 feet of elevation above 5000 feet above sea level up to 30° C at 10,000 feet. For optimum reliability and performance, the recommended operating range is 20° to 25° C

### Environmental Temperature Sensor

To ensure that the system is operating within the published limits, the ambient operating temperature is measured using a sensor placed near the chassis inlet, between the cell boards. Data from the sensor is used to control the fan speed and to initiate system overtemp shutdown.

### Non-Operating Environment

The system is designed to withstand ambient temperatures between -40° to 70° C under non-operating conditions.

## Cooling

### Cell Section Cooling

The cabinet incorporates front to back airflow across the cell boards and system backplane. Two 150 mm fans, mounted externally on the front chassis wall behind the cosmetic front bezel, push air into the cell section; and two 150 mm fans housed in cosmetic plastic fan carriers and mounted externally to the rear chassis wall, pull air through the cell section.

Each cell area fan cooling is controlled by a smart fan control board, embedded in the fan module plastic housing. The smart fan control board receives fan control input from the system fan controller on the system backplane and returns fan status information to the system fan controller. The smart fan control board also controls the power and the pulse width modulated control signal to the fan and monitors the speed indicator back from the fan. The fan status LED is driven by the smart fan control board.

### BPS Cooling

Cooling for the BPS is provided by two 60 mm fans contained within each BPS. Air flows into the front of the BPS and is exhausted out of the top of the power supply through upward facing vents near the rear of the supply. The air is then ducted out of the rear of the chassis with minimal leakage into the cell airflow plenum.

### PCI/Mass Storage Section Cooling

Six 92 mm fans located between the mass storage devices and the PCI card cage provide airflow through these devices. The PCI fans are powered with housekeeping power and run at full speed at all times. The air is pulled through the mass storage devices and pushed through the PCI card cage. Perforation is provided between the PCI bulkheads to allow adequate exhaust ventilation and to help reduce the localized airflow dead spots that typically occur at the faceplate tail of each PCI card.

### Standby Cooling

Several components within the chassis consume significant amounts of power while the system is in standby mode. The system fans run at 1541 rpm, or 38% of full speed, during standby to remove the resulting heat from the cabinet. The fans within the power supply will operate at full speed during standby.

### Typical Power Dissipation and Cooling

Table 1-5 Typical HP 9000 rp7420 Server Configurations

Cell Boards	Memory per Cell Board	PCI Cards (assumes 10 watts each)	DVDs	Hard Disk Drives	Core I/O	Bulk Power Supplies	Typical Power	Typical Cooling
Qty	GBytes	Qty	Qty	Qty	Qty	Qty	Watts	Btu/hr
2	16	16	1	4	2	2	2015	6879.21
2	8	8	0	2	2	2	1648	5626.27
2	4	8	0	2	2	2	1590	5482.26
1	4	8	0	1	1	2	995	3396.93

The air conditioning data is derived using the following equations.

- Watts x (0.860) = kcal/hour
- Watts x (3.414) = Btu/hour
- Btu/hour divided by 12,000 = tons of refrigeration required

---

**NOTE** When determining power requirements you must consider any peripheral equipment that will be installed during initial installation or as a later update. Refer to the applicable documentation for such devices to determine the power and air-conditioning that is required to support these devices.

---

### Acoustic Noise Specification

The acoustic noise specification for the HP 9000 rp7420 Server is 57.3 db (sound pressure level at bystander position). It is appropriate for dedicated computer room environments but not office environments. The LwA is 7.5 Bels. Be sure to understand the acoustic noise specifications relative to operator positions within the computer room or when adding servers to computer rooms with existing noise sources.

## Airflow

The HP 9000 rp7420 Server requires that the cabinet air intake temperature be between 68° and 77° F (20° and 25° C) at 332 CFM.

Figure 1-1 illustrates the location of the inlet and outlet airducts on a single cabinet.

**Figure 1-1**      **Airflow Diagram**

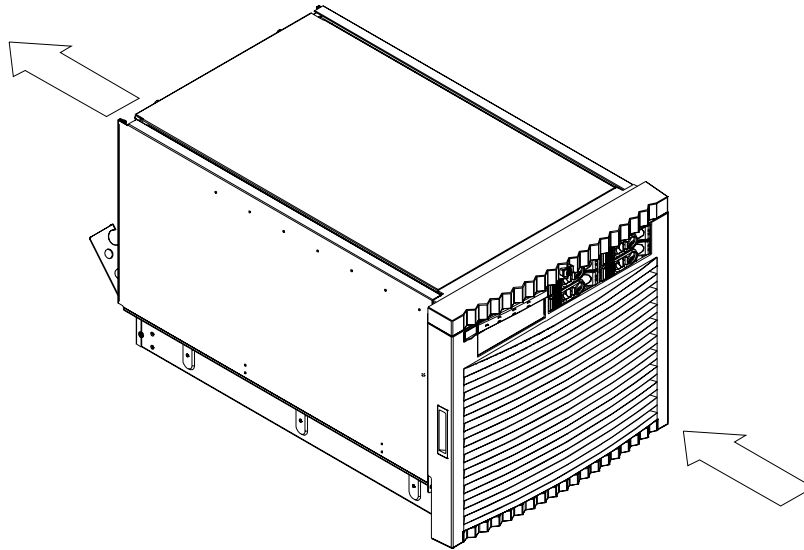

## System Requirements Summary

This section summarizes the requirements that must be considered in preparing the site for the HP 9000 rp7420 Server.

### Power Consumption and Air Conditioning

To determine the power consumed and the air conditioning required, follow the guidelines in Table 1-5.

**NOTE** When determining power requirements, consider any peripheral equipment that will be installed during initial installation or as a later update. Refer to the applicable documentation for such devices to determine the power and airconditioning that is required to support these devices.

Maximum power is the sum of the worst case power consumption of every subsystem in the box and should be used to size worst case power consumption. Typical power consumption numbers are what HP engineers have measured when running power-intensive applications. These are generally lower than maximum power numbers because all of the subsystems in the box to simultaneously drawing maximum power for long durations is uncommon.

### Weight

To determine overall weight, follow the examples in Table 1-6, then complete the entries in Table 1-7.

**Table 1-6 Example Weight Summary**

Component	Quantity	Multiply By	Weight
Cell Boards	2	27.80 lb / 12.61 kg	55.60 lb / 25.22 kg
PCI Card (varies – used A3739B here)	4	0.34 lb / 0.153 kg	1.36 lb / 0.61 kg
Power Supply (BPS)	2	18.0 lb / 8.2 kg	36 lb / 16.40 kg
DVD	1	2.2 lb / 1.0 kg	2.2 lb / 1.0 kg
Disk Drive	4	1.6 lb / 0.73 kg	6.40 lb / 2.90 kg
Chassis with skins and front bezel cover	1	131 lb / 59.42 kg	131 lb / 59.42 kg
Total weight			232.56 lb / 105.55kg

**Table 1-7 Weight Summary**

Component	Quantity	Multiply By	Weight (kg)
Cell Boards		27.80 lb / 12.61 kg	
PCI Card		weight varies	
Power Supply (BPS)		18 lb / 8.2 kg	
DVD		2.2 lb / 1.0 kg	



**Table 1-7 Weight Summary (Continued)**

<b>Component</b>	<b>Quantity</b>	<b>Multiply By</b>	<b>Weight (kg)</b>
Disk Drive		1.6 lb / 0.73 kg	
Chassis with skins and front bezel cover		131 lb / 59.42 kg	
		Total weight	



---

## **2 General Site Preparation Guidelines**

The following information provides general principles and practices to consider before the installation or operation of the system.

---

## Electrical Factors

---

**NOTE** Electrical practices and suggestions in this guide are based on North American practices. For regions and areas outside North America, local electrical codes will take precedence over North American electrical codes.

An example would be the recommendation that the Protective Earthing (PE) conductor be green with yellow stripes. This requirement is a North American directive and does not override the local code requirements for a region or area outside North America.

Local Authority Has Jurisdiction (LAHJ) and should make the final decision regarding adherence to region-specific or area-specific electrical codes and guidelines.

---

Proper design and installation of a power distribution system for the server requires specialized skills. Those responsible for this task must have a thorough knowledge and understanding of appropriate electrical codes and the limitations of the power systems for computer and data processing equipment.

In general, a well-designed power distribution system exceeds the requirements of most electrical codes. A good design, when coupled with proper installation practices, produces the most trouble-free operation.

A detailed discussion of power distribution system design and installation is beyond the scope of this document. However, electrical factors relating to power distribution system design and installation must be considered during the site preparation process. These factors include:

- Computer room safety
- Power consumption
- Electrical load requirements (circuit breaker sizing)
- Power quality
- Distribution hardware
- System installation guidelines

### Computer Room Safety

Inside the computer room, fire protection and adequate lighting (for equipment servicing) are important safety considerations. Federal and local safety codes govern computer installations.

#### Fire Protection

The national Fire Protection Association's Standard for the Protection of Electronic Computer Data Processing Equipment, NFPA 75, contains information on safety monitoring equipment for computer rooms.

Most computer room installations are equipped with the following fire protection devices:

- Smoke detectors
- Fire and temperature alarms
- Fire extinguishing system

Additional safety devices are:

- Circuit breakers
- An emergency power cutoff switch
- Devices specific to the geographic location, such as earthquake protection

### **Lighting Requirements for Equipment Servicing**

Adequate lighting and utility outlets in a computer room reduce the possibility of accidents during equipment servicing. Safer servicing is also more efficient and, therefore, less costly.

For example, it is difficult to see cable connection points on the hardware if lighting is inadequate. Adequate lighting reduces the chances of connector damage when cables are installed or removed.

The minimum recommended illumination level is 70 foot candles (756 lumens per square meter) when the light level is measured at 30 inches (76.2 cm) above the floor.

### **Working Space for Server Access**

The recommended working space for performing maintenance on the server is three feet. The work space will permit at least a 90 degree opening of equipment doors or hinged panels. When planning for the working space area, consider whether access to the server will be at the front, the side, or the rear of the server.

### **Power Consumption**

When determining power requirements, you must consider any peripheral equipment that will be installed during initial installation or as a later update. Refer to the applicable documentation for such devices to determine the power required to support these devices.

### **Electrical Load Requirements (Circuit Breaker Sizing)**

---

**NOTE** LAHJ and should make the final decision regarding adherence to country-specific electrical codes and guidelines.

---

It is good practice to derate power distribution systems for the following reasons:

- To avoid nuisance tripping from load shifts or power transients, circuit protection devices should never be run above 80% of their root-mean-square (RMS) current ratings.
- Safety agencies derate most power connectors to 80% of their RMS current ratings.

### **Power Quality**

The server is designed to operate over a wide range of voltages and frequencies. The server has been tested and shown to comply with EMC Specification EN50082. However, damage can occur if these ranges are exceeded. Severe electrical disturbances can exceed the design specifications of the equipment.

### **Sources of Voltage Fluctuations**

Voltage fluctuations, sometimes called glitches, affect the quality of electrical power. Common sources of these disturbances are:

- Fluctuations occurring within the facility's distribution system

## Electrical Factors

- Utility service low-voltage conditions (such as sags or brownouts)
- Wide and rapid variations in input voltage levels
- Wide and rapid variations in input power frequency
- Electrical storms
- Large inductive sources (such as motors and welders)
- Faults in the distribution system wiring (such as loose connections)
- Microwave, radar, radio, or cell phone transmissions

### Power System Protection

The server can be protected from the sources of many of these electrical disturbances by using:

- A dedicated power distribution system
- Power conditioning equipment
- Over- and under-voltage detection and protection circuits
- Screening to cancel the effects of undesirable transmissions
- Lightning arresters on power cables to protect equipment from electrical storms

Every precaution has been taken during power distribution system design to provide immunity to power outages of less than one cycle. However, testing cannot conclusively rule out loss of service. Therefore, adherence to the following guidelines provides the best possible performance of power distribution systems for server equipment:

- A dedicated power source isolates the server power distribution system from other circuits in the facility.
- Missing-phase and low-voltage detectors automatically shuts equipment down when a severe power disruption occurs. For peripheral equipment, these devices are recommended but optional.
- An online uninterruptible power supply (UPS) keeps input voltage to devices constant and should be considered if outages of one-half cycle or more are common. Refer to qualified contractors or consultants for each situation.

## Distribution Hardware

This section describes wire selection and the types of raceways (electrical conduits) used in the distribution system.

### Wire Selection

Use copper conductors instead of aluminum because the expansion coefficient of aluminum differs significantly from that of other metals used in power hardware. Because of this difference, aluminum conductors can cause connector hardware to loosen, overheat, and fail.

### Raceway Systems (Electrical Conduits)

Raceways (electrical conduits) form part of the protective ground path for personnel and equipment. Raceways protect the wiring from accidental damage and provide a heatsink for the wires.

Any of the following types can be used:

- Electrical Metallic Tubing (EMT) thin-wall tubing
- Rigid (metal) conduit

- Liquidtight with RFI strain relief (most commonly used with raised floors)

### **Building Distribution**

All building feeders and branch circuitry should be in rigid metallic conduit with proper connectors (to provide ground continuity). Conduit that is exposed and subject to damage should be constructed of rigid galvanized steel.

### **Power Routing**

Power drops and interface cables from the equipment are routed down from the power panel through a grommet protected opening (beneath the floor level) and under the floor panels.

## **Grounding Systems**

The server requires two methods of grounding:

- Power distribution safety grounding
- High frequency intercabinet grounding

### **Power Distribution Safety Grounding (LAHJ)**

The power distribution safety grounding system consists of connecting various points in the power distribution system to earth ground using green (green/yellow) wire ground conductors. Having these ground connections tied to metal chassis parts that computer room personnel might touch protects them against shock hazard from current leakage and fault conditions.

Power distribution systems consist of several parts. HP recommends that these parts be solidly interconnected to provide an equipotential ground to all points.

### **Main Building Electrical Ground**

The main electrical service entrance equipment should have an earth ground connection, as required by applicable codes. Connections, such as a grounding rod, building steel, or a conductive type cold water service pipe, provide an earth ground.

### **Electrical Conduit Ground**

All electrical conduits should be made of rigid metallic conduit that is securely connected together or bonded to panels and electrical boxes to provide a continuous grounding system.

### **Power Panel Ground**

Each power panel should be grounded to the electrical service entrance with green (green/yellow) wire ground conductors. The green (green/yellow) wire ground conductors should be sized per applicable codes (based on circuit over current device ratings).

---

**NOTE**      The green wire ground conductor may be a black wire marked with green tape. (LAHJ)

---

### **Computer Safety Ground**

Ground all computer equipment with the green (green/yellow) wire included in the branch circuitry. The green (green/yellow) wire ground conductors should be connected to the appropriate power panel and should be sized per applicable codes (based on circuit over current device ratings).

### Dual Power Source Grounding

When dual power sources are utilized, strong consideration should be given to measure voltage potentials. The use of dual power might create an electrical potential that can be hazardous to personnel and might cause performance issues for the equipment.

Dual power sources might originate from two different transformers or two different UPS devices. Voltage potentials from ground pin to ground pin for these sources should be measured and verified to be at or near 0.0 volts. Voltage levels that deviate or are measured above 3.0 volts should be further investigated. Increased voltages might be hazardous to personnel.

### Cabinet Performance Grounding (High-Frequency Ground)

Signal interconnects between system cabinets require high frequency ground return paths. Connect all cabinets to site ground.

---

**NOTE** In some cases, power distribution system green (green/yellow) wire ground conductors are too long and inductive to provide adequate high-frequency ground return paths. Therefore, the server is shipped with a ground strap for connecting the system cabinet to the site grounding grid (customer-supplied). When connecting this ground, ensure that the raised floor is properly grounded.

---

Power panels located in close proximity to the computer equipment should also be connected to the site grounding grid. Methods of providing a sufficiently high frequency ground grid are described in the next sections.

### Raised Floor “High Frequency Noise” Grounding

If a raised floor system is used, install a complete signal reference grid for maintaining equal potential over a broad band of frequencies. The grid should be connected to the equipment cabinet and electrical service entrance ground at multiple connection points using a minimum #6 AWG (16 mm) wire ground conductor. The following figure illustrates a metallic strip grounding system.

---

**NOTE** Regardless of the grounding connection method used, the raised floor should be grounded as an absolute safety minimum.

---

HP recommends the following approaches:

- **Excellent**—Add a signal reference grid to the subfloor. The grid should be made of aluminum strips mounted to the subfloor. The strips should be 0.032 in. (0.08 cm) thick and a minimum of 3.0 in. (8.0 cm) wide.  
Connect each pedestal to four strips using 0.25 in. (6.0 mm) bolts tightened to the manufacturer’s torque recommendation.
- **Better**—A grounded #6 AWG minimum copper wire grid mechanically clamped to floor pedestals and properly bonded to the building/site ground.



- Good—Use the raised floor structure as a signal reference grid. In this case, the floor must be designed as a ground grid with bolted stringers and corrosion resistant plating (to provide low resistance and attachment points for connection to service entrance ground and server equipment). The use of conductive floor tiles with this style of grid further enhances ground performance. The structure needs to be mechanically bonded to a known good ground point.

**Figure 2-1 Raised Floor Ground System**

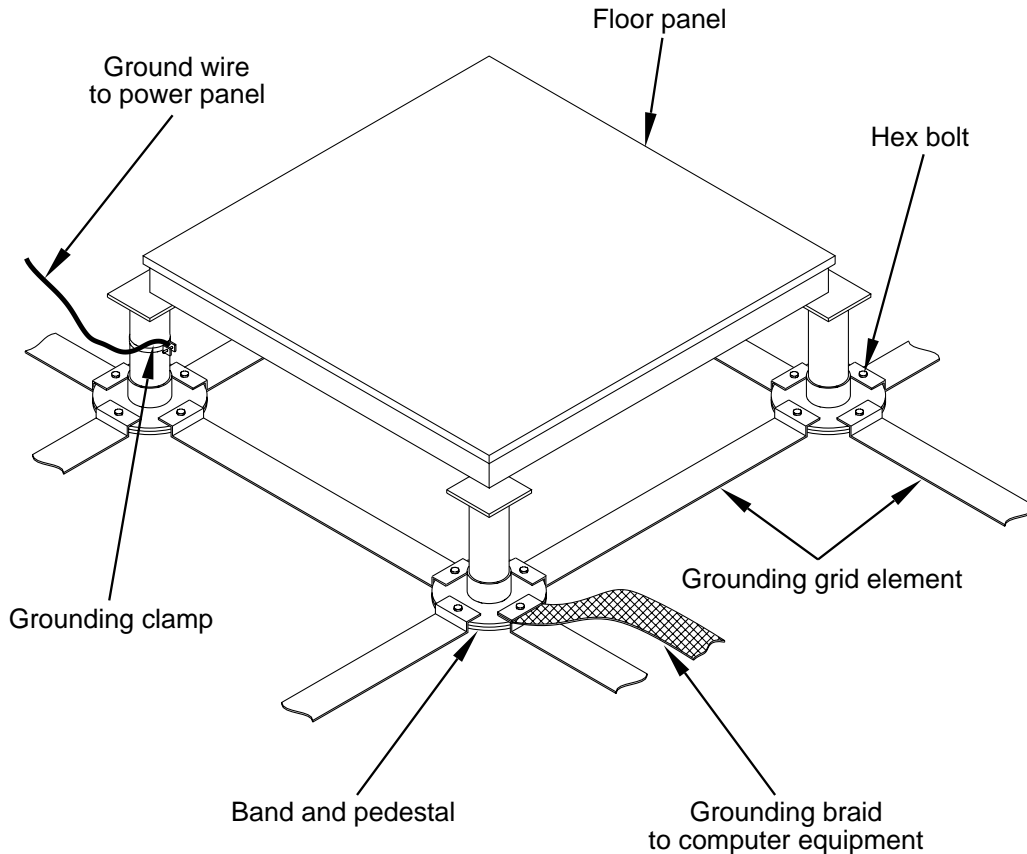

### Equipment Grounding Implementation Details

Connect all HP equipment cabinets to the site ground grid as follows:

1. Attach one end of each ground strap to the applicable cabinet ground lug.
2. Attach the other end to the nearest pedestal base (raised floor) or cable trough ground point (nonraised floor).
3. Check that the braid contact on each end of the ground straps consists of a terminal and connection hardware (a 0.25 in. (6.0 mm) bolt, nuts, and washers).
4. Check that the braid contact connection points are free of paint or other insulating material and are treated with a contact enhancement compound (similar to Burndy Penetrox).

## System Installation Guidelines

This section contains information about installation practices. Some common problems are highlighted. Both power cable and data communications cable installations are discussed.

---

**NOTE** In domestic installations, the proper receptacles should be installed before the arrival of HP equipment. Refer to the appropriate installation guide for installation procedures.

---

### Wiring Connections

Expansion and contraction rates vary among different metals. Therefore, the integrity of an electrical connection depends on the restraining force applied. Connections that are too tight compress or deform the hardware and causes it to weaken. This usually leads to high impedance causing circuit breakers to trip.

---

**CAUTION** Connections that are too loose have a high resistance that can cause serious problems, such as erratic equipment operation. A high-resistance connection can overheat and cause fire or high temperatures that can destroy hard-to-replace components, such as distribution panels or system bus bars.

---

Wiring connections must be properly torqued. Many equipment manufacturers specify the proper connection torque values for their hardware.

Ground connections must only be made on a conductive, nonpainted surface. When equipment vibration is present, lockwashers must be used on all connections to prevent connection hardware from loosening.

### Data Communications Cables

Power transformers and heavy foot traffic create high energy fields. Route data communications cables away from these areas. Use shielded data communications cables that meet approved industry standards to reduce the effects of external fields.

## Environmental Elements

The following environmental elements can affect server installation:

- Computer room preparation
- Cooling requirements
- Humidity level
- Air conditioning ducts
- Dust and pollution control
- Metallic particle contamination
- ESD prevention
- Acoustics (noise reduction)

## Computer Room Preparation

The following guidelines are recommended when preparing a computer room for the server:

- Locate the computer room away from the exterior walls of the building to avoid the heat gain from windows and exterior wall surfaces.
- When exterior windows are unavoidable, use windows that are double- or triple-glazed and shaded to prevent direct sunlight from entering the computer room.
- Maintain the computer room at a positive pressure relative to surrounding spaces.
- Use a vapor barrier installed around the entire computer room envelope to restrain moisture migration.
- Caulk and vapor seal all pipes and cables that penetrate the envelope.
- Use at least a 12-inch raised floor system for the most favorable room air distribution system (underfloor distribution).
- Ensure a minimum ceiling height of 12 inches between the top of the server and the ceiling and that all ceiling clips are in place.
- Allow 18 inches (or local code minimum clearance) from the top of the server cabinet to the fire sprinkler heads.

## Cooling Requirements

Air conditioning equipment requirements and recommendations are described in the following sections.

### Basic Air Conditioning Equipment Requirements

The cooling capacity of the installed air conditioning equipment for the computer room should be sufficient to offset the computer equipment dissipation loads, as well as any space envelope heat gain. This equipment should include:

- Air filtration
- Cooling or dehumidification
- Humidification

## Environmental Elements

- Reheating
- Air distribution
- System controls adequate to maintain the computer room within the operating range

Lighting and personnel must also be included. For example, a person dissipates about 450 Btu/hr while performing a typical computer room task.

At altitudes above 10,000 ft (3048 m), the lower air density reduces the cooling capability of air conditioning systems. If your facility is located above this altitude, the recommended temperature ranges might need to be modified. For each 1000 ft (305 m) increase in altitude above 10,000 feet (up to a maximum of 15,000 ft), subtract 1.5° F (0.83° C) from the upper limit of the temperature range.

### Air Conditioning System Guidelines

The following guidelines are recommended when designing an air conditioning system and selecting the necessary equipment:

- The air conditioning system that serves the computer room should be capable of operating 24 hours a day, 365 days a year. It should also be independent of other systems in the building.
- Consider the long-term value of computer system availability, redundant air conditioning equipment, or capacity.
- The system should be capable of handling any future computer system expansion.
- Air conditioning equipment air filters should have a minimum rating of 45% (based on “ASHRAE Standard 52-76, Dust Spot Efficiency Test”).
- Introduce only enough outside air into the system to meet building code requirements (for human occupancy) and to maintain a positive air pressure in the computer room.

### Air Conditioning System Types

The following four air conditioning system types are listed in order of preference:

- Complete self-contained package units with remote condenser. These systems are available with up or down discharge and are usually located in the computer room.
- Chilled water package unit with remote chilled water plant. These systems are available with up or down discharge and are usually located in the computer room.
- Central station air handling units with remote refrigeration equipment. These systems are usually located outside the computer room.
- Scalable overhead distribution system. These systems distribute water overhead to air heat exchangers, which cool the air locally over the servers. A system called DataCool is primarily used in high density environments of 100 to 500 watts per square foot.

### Basic Air Distribution Systems

A basic air distribution system includes supply air and return air.

An air distribution system should be zoned to deliver an adequate amount of supply air to the cooling air intake vents of the computer system equipment cabinets. Supply air temperature should be maintained within the following parameters:

- Ceiling supply system—From 55° to 60° F (12.8 to 15.6° C)
- Floor supply system—At least 60° F (15.6° C)

If a ceiling plenum return air system or a ducted ceiling return air system is used, the return air grilles in the ceiling should be located directly above the computer equipment cabinets.

The following three types of air distribution system are listed in order of recommendation:

- Underfloor air distribution system. Downflow air conditioning equipment located on the raised floor of the computer room uses the cavity beneath the raised floor as plenum for the supply air.

Perforated floor panels (available from the raised floor manufacturer) should be located around the perimeter of the system cabinets. Supply air emitted through the perforated floor panels is then available near the cooling air intake vents of the computer system cabinets.

- Ceiling plenum air distribution system. Supply air is ducted into the ceiling plenum from upflow air conditioning equipment located in the computer room or from an air handling unit (remote).

The ceiling construction should resist air leakage. Place perforated ceiling panels (with down discharge air flow characteristics) around the perimeter of the system cabinets. The supply air emitted downward from the perforated ceiling panels is then available near the cooling air intake vents of the computer system cabinets.

Return air should be ducted back to the air conditioning equipment through the return air duct above the ceiling.

- Above ceiling ducted air distribution system. Supply air is ducted into a ceiling diffuser system from upflow air conditioning equipment located in the computer room or from an air handling unit (remote).

Adjust the supply air diffuser system grilles to direct the cooling air downward around the perimeter of the computer system cabinets. The supply air is then available near the cooling air intake vents of the computer system cabinets.

**Table 2-1 Computer Room Environment**

Parameter	Operating Limits	Recommended Operating Range	Maximum Rate of Change (per hour)	Non-Operating Ranges
Temperature <sup>a</sup>	41° to 95° F (5° to 35° C)	68° to 77° F (20° to 25° C)	9° F repetitive 36° F non repetitive (5° C repetitive, 20° C nonrepetitive)	-40° C to +70° C
Humidity	15% to 80% with no condensation (40% to 55% recommended)	40% to 55% RH non-condensing	6%	90% RH non-condensing at 65° C (149° F)

a. The temperature ranges stated are at 0 to 5,000 ft. The maximum operating temperature must be derated by 1° C/1,000 ft from 5,000 to 10,000 ft.

### Air Conditioning System Installation

All air conditioning equipment, materials, and installation must comply with any applicable construction codes. Installation of the various components of the air conditioning system must also conform to the air conditioning equipment manufacturer's recommendations.

## Air Conditioning Ducts

Use separate computer room air conditioning duct work. If it is not separate from the rest of the building, it might be difficult to control cooling and air pressure levels. Duct work seals are important for maintaining a balanced air conditioning system and high static air pressure. Adequate cooling capacity means little if the direction and rate of air flow cannot be controlled because of poor duct sealing. Also, the ducts should not be exposed to warm air, or humidity levels might increase.

## Humidity Level

Maintain proper humidity levels at 40 to 55% RH. High humidity causes galvanic actions to occur between some dissimilar metals. This eventually causes a high resistance between connections, leading to equipment failures. High humidity can also have an adverse affect on some magnetic tapes and paper media.

---

**CAUTION** Low humidity contributes to undesirably high levels of electrostatic charges. This increases the ESD voltage potential. ESD can cause component damage during servicing operations. Paper feed problems on high-speed printers are usually encountered in low-humidity environments.

---

Low humidity levels are often the result of the facility heating system and occur during the cold season. Most heating systems cause air to have a low humidity level, unless the system has a built-in humidifier.

## Dust and Pollution Control

Computer equipment can be adversely affected by dust and microscopic particles in the site environment.

Specifically, disk drives, tape drives, and some other mechanical devices can have bearing failures resulting from airborne abrasive particles. Dust might also blanket electronic components, like printed circuit boards, causing premature failure from excess heat and humidity build-up on the boards. Other failures to power supplies and other electronic components can be caused by metallically conductive particles. These metallic particles are conductive and can short circuit electronic components. Use every effort to ensure that the environment is as dust- and particulant-free as possible.

Smaller particles can pass through some filters and, over a period of time, can cause problems in mechanical parts. Small dust particles can be prevented from entering the computer room by maintaining its air conditioning system at a high-static air pressure level.

Other sources of dust, metallic, conductive, abrasive, or microscopic particles can be present. Some sources of these particulants are:

- Subfloor shedding
- Raised floor shedding
- Ceiling tile shedding

These pollutants are not always visible to the naked eye. Check the underside of the tiles to determine the presence of these pollutants. The tile should be shiny, galvanized, and free of rust.

The computer room should be kept clean. The following guidelines are recommended:

- Establish a no-smoking policy. Cigarette smoke particles are eight times larger than the clearance between disk drive read/write heads and the disk surface.
- Locate printers and paper products in a separate room to eliminate paper particulate problems.
- Establish a no eating or drinking policy. Spilled liquids can cause short circuits in equipment such as keyboards.

- Use a dust-absorbent cloth mop rather than a dry mop to clean tile floors.

Special precautions are necessary if the computer room is near a source of air pollution. Some air pollutants, especially hydrogen sulfide, are not only unpleasant but corrosive as well. Hydrogen sulfide damages wiring and delicate sound equipment. The use of activated charcoal filters reduces this form of air pollution.

## Metallic Particle Contamination

Metallic particulates can be especially harmful around electronic equipment. This type of contamination can enter the data center environment from a variety of sources, including but not limited to, raised floor tiles, worn air conditioning parts, heating ducts, rotor brushes in vacuum cleaners, or worn printer components. Because metallic particulates conduct electricity, they have an increased potential for creating short circuits in electronic equipment. This problem is exaggerated by the increasingly dense circuitry of electronic equipment.

Over time, very fine whiskers of pure metal can form on electroplated zinc, cadmium, or tin surfaces. If these whiskers are disturbed, they can break off and become airborne, possibly causing failures or operational interruptions. For over 50 years, the electronics industry has been aware of the relatively rare but possible threat posed by metallic particulate contamination. During recent years, a growing concern has developed in computer rooms where these conductive contaminants are formed on the bottom of some raised floor tiles.

Although this problem is relatively rare, it might be an issue within your computer room. Since metallic contamination can cause permanent or intermittent failures on your electronic equipment, HP strongly recommends that your site be evaluated for metallic particulate contamination before installation of electronic equipment.

## Electrostatic Discharge Prevention

Static charges (voltage levels) occur when objects are separated or rubbed together. The voltage level of a static charge is determined by the following factors:

- Types of materials
- Relative humidity
- Rate of change or separation

Table 2-2 lists charge levels based on personnel activities and humidity levels.

**Table 2-2 Effect of Humidity on ESD Charge Levels**

Personnel Activity <sup>a</sup>	Humidity <sup>b</sup> and Charge Levels <sup>c</sup>			
	26%	32%	40%	50%
<b>Walking across a linoleum floor</b>	<b>6,150 V</b>	<b>5,750 V</b>	<b>4,625 V</b>	<b>3,700 V</b>
Walking across a carpeted floor	18,450 V	17,250 V	13,875 V	11,100 V
Rising from a plastic chair	24,600 V	23,000 V	18,500 V	14,800 V

a. Source: B.A. Unger, *Electrostatic Discharge Failures of Semiconductor Devices* (Bell Laboratories, 1981)

b. For the same relative humidity level, a high rate of airflow produces higher static charges than a low airflow rate.

c. Some data in this table has been extrapolated.

### **Static Protection Measures**

Follow these precautions to minimize possible ESD-induced failures in the computer room:

- Install conductive flooring (conductive adhesive must be used when laying tiles).
- Use conductive wax if waxed floors are necessary.
- Ensure that all equipment and flooring are properly grounded and are at the same ground potential.
- Use conductive tables and chairs.
- Use a grounded wrist strap (or other grounding method) when handling circuit boards.
- Store spare electronic modules in antistatic containers.
- Maintain recommended humidity level and airflow rates in the computer room.

### **Acoustics**

Computer equipment and air conditioning blowers cause computer rooms to be noisy. Ambient noise level in a computer room can be reduced as follows:

- Cover the ceiling with a commercial grade of fire-resistant, acoustic rated, fiberglass ceiling tile.
- Cover the walls with curtains or other sound deadening material.
- Use foam rubber models as removable partitions for most effectiveness.



---

## Facility Characteristics

This section contains information about facility characteristics that must be considered for the installation or operation of the server. Facility characteristics are:

- Floor loading
- Windows
- Altitude effects

### Floor Loading

The computer room floor must be able to support the total weight of the installed computer system as well as the weight of the individual cabinets as they are moved into position.

Floor loading is usually not an issue in nonraised floor installations. The information presented in this section is directed toward raised floor installations.

---

**NOTE** Any floor system under consideration for a server installation should be verified by an appropriate floor system consultant.

---

### Raised Floor Loading

Raised floor loading is a function of the manufacturer's load specification and the positioning of the equipment relative to the raised floor grid. Though HP cannot assume responsibility for determining the suitability of a particular raised floor system, it does provide information and illustrations for the customer or local agencies to determine installation requirements.

The following guidelines are recommended:

- Because many raised floor systems do not have grid stringers between floor stands, the lateral support for the floor stands depends on adjacent panels being in place. To avoid compromising this type of floor system while gaining under floor access, remove only one floor panel at a time.
- Larger floor grids (bigger panels) are generally rated for lighter loads.

---

**CAUTION** Do not install any raised floor system until you have carefully examined it to verify that it is adequate to support the appropriate installation.

---

### Floor Loading Terms

Table 2-3 defines floor loading terms.

**Table 2-3 Floor Loading Term Definitions**

Term	Definition
Dead load	The weight of the raised panel floor system, including the understructure. Expressed in lb/ft <sup>2</sup> (kg/m <sup>2</sup> ).
Live load	The load that the floor system can safely support. Expressed in lb/ft <sup>2</sup> (kg/m <sup>2</sup> ).

**Table 2-3 Floor Loading Term Definitions (Continued)**

Term	Definition
Concentrated load	The load that a floor panel can support on a one square inch (6.45 cm <sup>2</sup> ) area at the panel’s weakest point (typically the center of the panel), without the surface of the panel deflecting more than a predetermined amount.
Ultimate load	The maximum load (per floor panel) that the floor system can support without failure. Failure expressed by floor panel(s) breaking or bending.  Ultimate load is usually stated as load per floor panel.
Rolling load	The load a floor panel can support (without failure) when a wheel of specified diameter and width is rolled across the panel.
Average floor load	Computed by dividing total equipment weight by the area of its footprint. This value is expressed in lb/ft <sup>2</sup> (kg/m <sup>2</sup> ).

**Average Floor Loading**

The average floor load value, defined in Table 2-4, is not appropriate for addressing raised floor ratings at the floor grid spacing level. However, it is useful for determining floor loading at the building level, such as the area of solid floor or span of raised floor tiles covered by the server footprint.

**Typical Raised Floor Site**

This section contains an example of a computer room raised floor system that is satisfactory for the installation of a server.

Based on specific information provided by HP, Tate Access Floors has approved its Series 800 all-steel access floor with bolt-together stringers and 24 in. (61.0 cm) by 24 in. (61.0 cm) floor panels.

In the event that the flooring is being replaced or a new floor is being installed, Tate Access Floors recommends its Series 1250 all-steel access floor with bolt-together stringers and 24 in. (61.0 cm) by 24 in. (61.0 cm) floor panels be used to support the server installation.

---

**NOTE** If the specific floor being evaluated or considered is other than a Tate Series 800 floor, the specific floor manufacturer must be contacted to evaluate the floor being used.

---

Table 2-4 lists specifications for the Tate Access Floors Series 800 raised floor system.

**Table 2-4 Typical Raised Floor Specifications**

Item <sup>a</sup>	Rating
Dead load	7 lb/ft <sup>2</sup> (34.2 kg/m <sup>2</sup> )
Live load	313 lb/ft <sup>2</sup> (1528.3 kg/m <sup>2</sup> )
Concentrated load <sup>b</sup>	1250 lb (567 kg)

**Table 2-4 Typical Raised Floor Specifications (Continued)**

<b>Item<sup>a</sup></b>	<b>Rating</b>
Ultimate load	4000 lb (1814 kg) per panel
Rolling load	400 lb (181 kg)
Average floor load	500 lb (227 kg)

- a. From Table 2-3 on page 25
- b. With 0.08 in. (0.2 cm) of span maximum deflection

## **Windows**

Avoid housing computers in a room with windows. Sunlight entering a computer room can cause problems. Magnetic tape storage media is damaged if exposed to direct sunlight. Also, the heat generated by sunlight places an additional load on the cooling system.

---

## Space Requirements

This section contains information about space requirements for a server. This data should be used as the basic guideline for space plan developments. Other factors, such as airflow, lighting, and equipment space requirements must also be considered.

### Delivery Space Requirements

There should be enough clearance to move equipment safely from the receiving area to the computer room. Permanent obstructions, such as pillars or narrow doorways, can cause equipment damage.

Delivery plans should include the possible removal of walls or doors.

**Figure 2-2 Cabinet Dimensions**

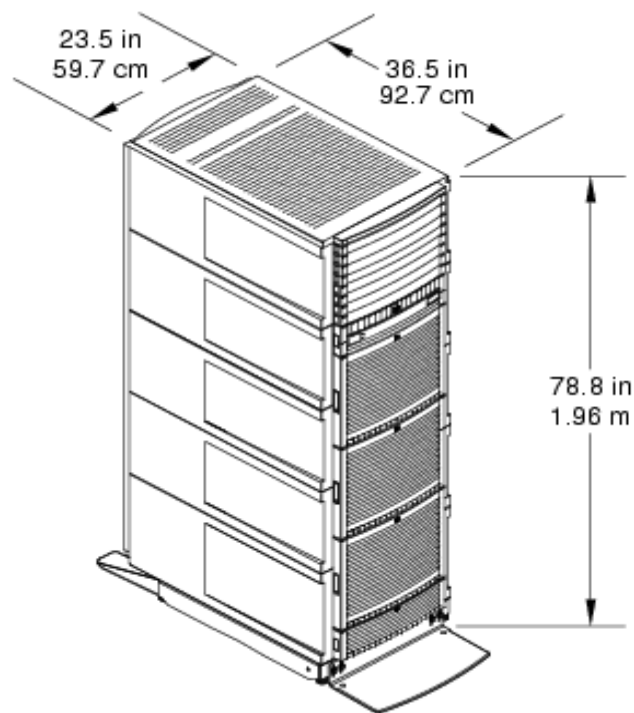

### Operational Space Requirements

Other factors must be considered along with the basic equipment dimensions. Reduced airflow around equipment causes overheating, which can lead to equipment failure. Therefore, the location and orientation of air conditioning ducts, as well as airflow direction, are important. Obstructions to equipment intake or exhaust airflow must be eliminated.

The locations of lighting fixtures and utility outlets affect servicing operations. Plan equipment layout to take advantage of lighting and utility outlets. Do not forget to include clearance for opening and closing equipment doors.

Clearance around the cabinets must be provided for proper cooling airflow through the equipment.

The service area space requirements, shown in Figure 2-3, are minimum dimensions. If other equipment is located so that it exhausts heated air near the cooling air intakes of the computer system cabinets, larger space requirements are needed to keep ambient air intake to the computer system cabinets within the specified temperature and humidity ranges.

**Figure 2-3 Footprint**

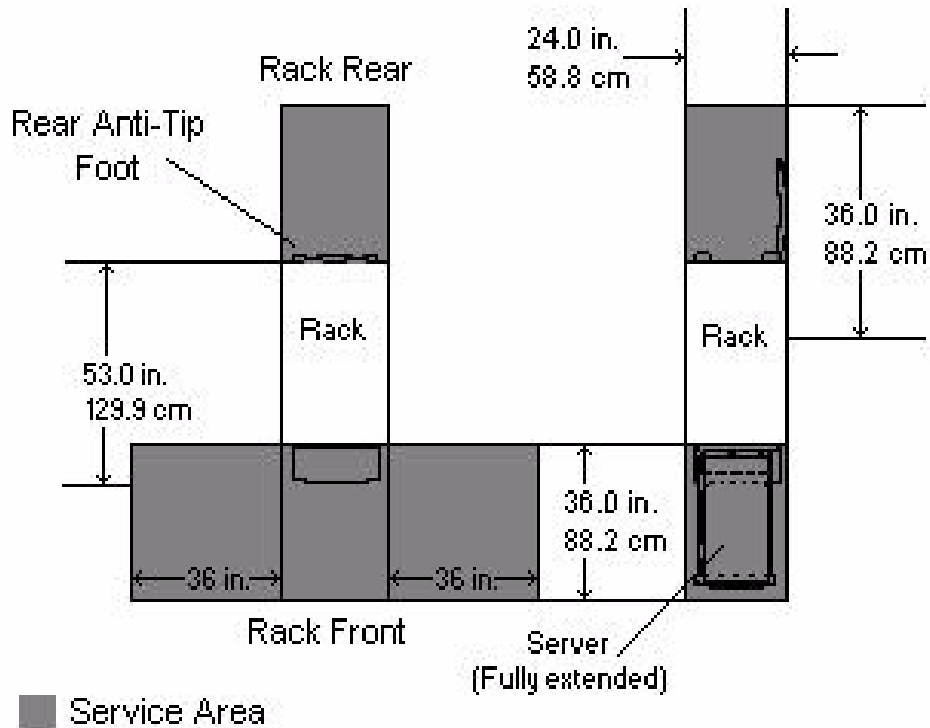

Space planning should also include the possible addition of equipment or other changes in space requirements. Equipment layout plans should also include provisions for the following:

- Channels or fixtures used for routing data cables and power cables
- Access to air conditioning ducts, filters, lighting, and electrical power hardware
- Power conditioning equipment
- Cabinets for cleaning materials
- Maintenance area and spare parts

## Equipment Footprint Templates

The equipment footprint template and floor plan grid are drawn to the same scale (0.25 in. = 1 ft). These templates are provided to show basic equipment dimensions and space requirements for servicing.

The service areas shown on the template drawings are lightly shaded.

The equipment templates should be used with the floor plan grid to define the location of the equipment that will be installed in your computer room.

---

**NOTE** Photocopying typically changes the scale of drawings copied. If any templates are copied, then all templates and floor plan grids must also be copied.

---

## **Computer Room Layout Plan**

Use the following procedure to create a computer room layout plan:

1. Remove the floor plan grid from the document. See Figure 2-4.
2. Remove a copy of each applicable equipment footprint template. See Figure 2-3.
3. Cut out each template selected in 2, then place it on the floor plan grid.

4. Position the pieces until the desired layout is obtained, then fasten the pieces to the grid. Mark locations of computer room doors, air conditioning floor vents, utility outlets, and so on.

**Figure 2-4 Planning Grid**

Scale: 1/4 inch = 1 foot

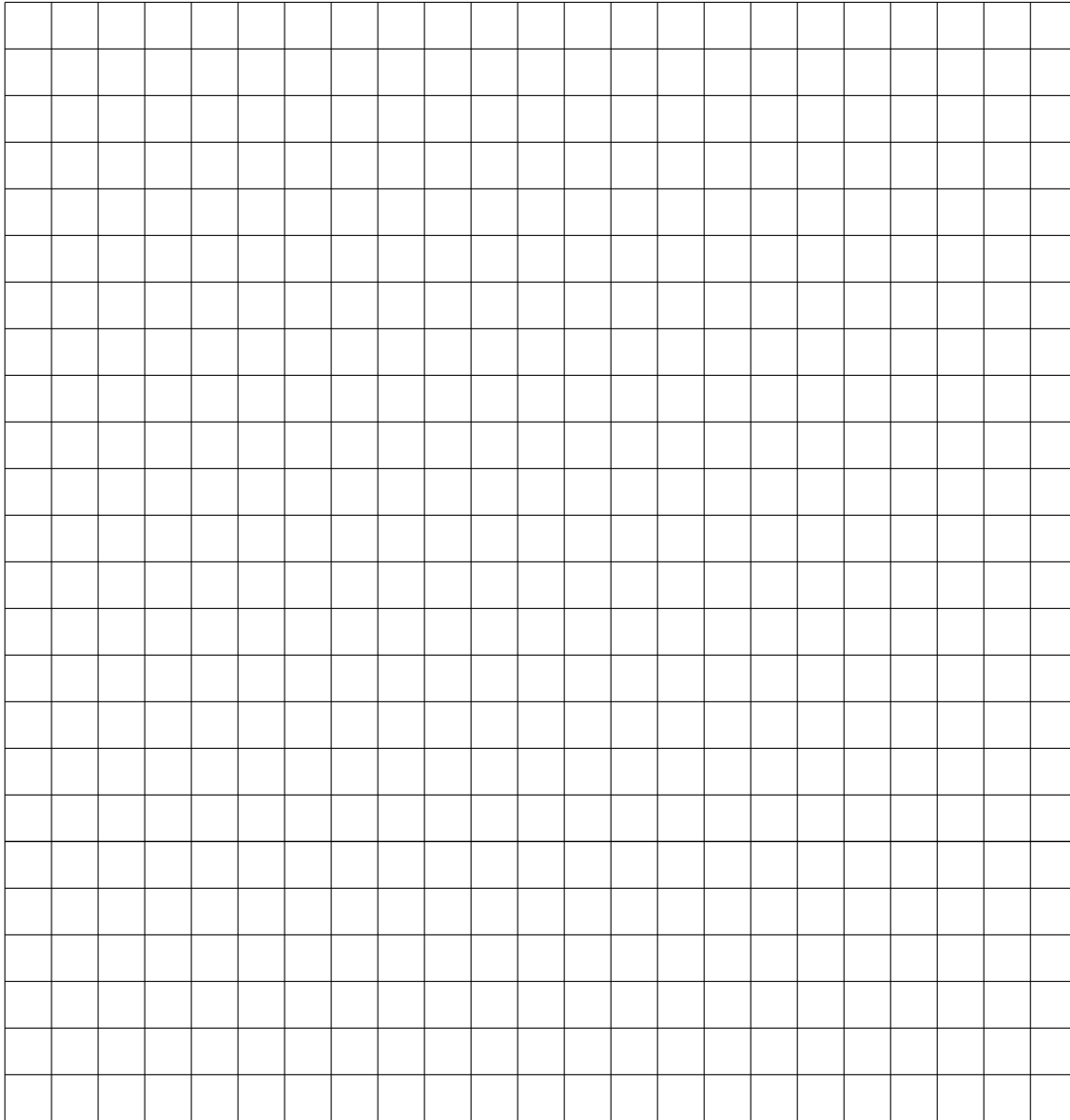

60SP016A  
12/20/99



---

## Power Plug Configuration

There are several different power cables designed for use with hp servers. The region the server ships to will determine which power cable ships with the server. The following provides the site preparation specialist with the knowledge of what to expect to receive based on the regional shipping destination.

### Female End of Power Cable

The female end of the HP server is a C19 type plug that mates with the C20 receptacle in each power supply installed in the hp server.

**Figure 2-5 C20 Male Receptacle (at power supply)**

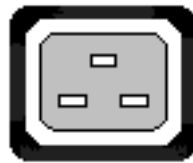

**Figure 2-6 C19 Female Plug (on one end of the power cord)**

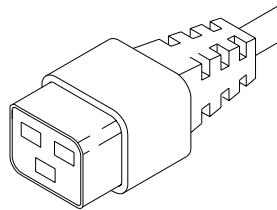

### Male End of Power Cable

The male plug on the other end of the power cable will vary depending on the region to which the HP server is shipped.

---

**NOTE** This collection of examples is not meant to be all inclusive nor is it meant to imply every plug shown is one that is available for the server.

---

**Figure 2-7**      **Unterminated Plug**

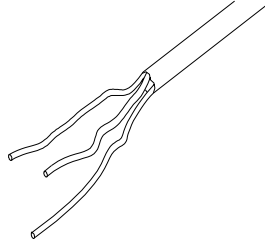

**Figure 2-8**      **L6-20 Plug**

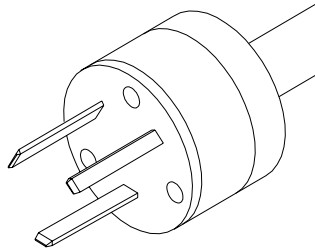

**Figure 2-9**      **IEC 309 Plug**

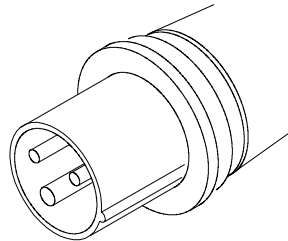

**Figure 2-10**      **CEE 7-7 Plug**

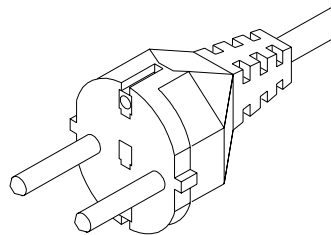

**Figure 2-11 L6-30 Plug**

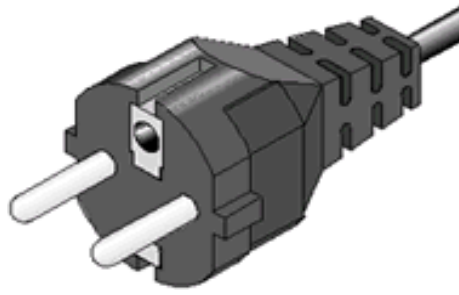

**Figure 2-12 NEMA 5-20P Plug**

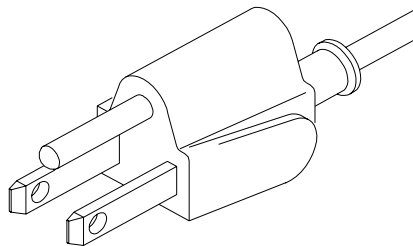

**Figure 2-13 ISI 32 Plug**

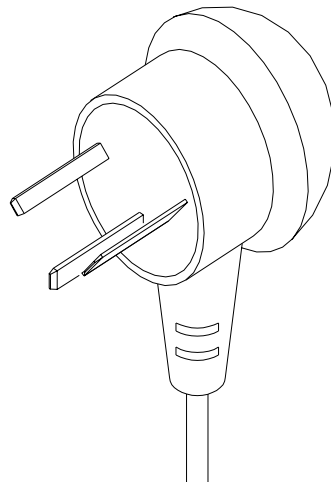

**Figure 2-14 GB 1002 Plug**

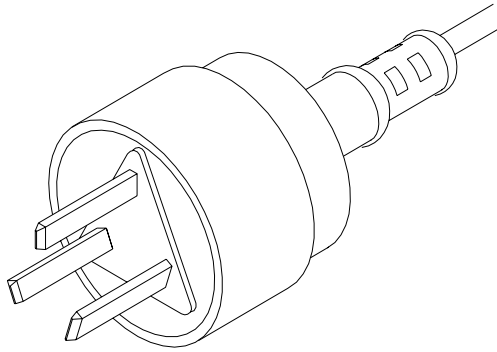

**Power Cable**

The power cable length and configuration will vary based on the region to which the server ships. This is an example of one power cable configuration used to supply power to the server.

**Figure 2-15 L6-20 Power Cable**

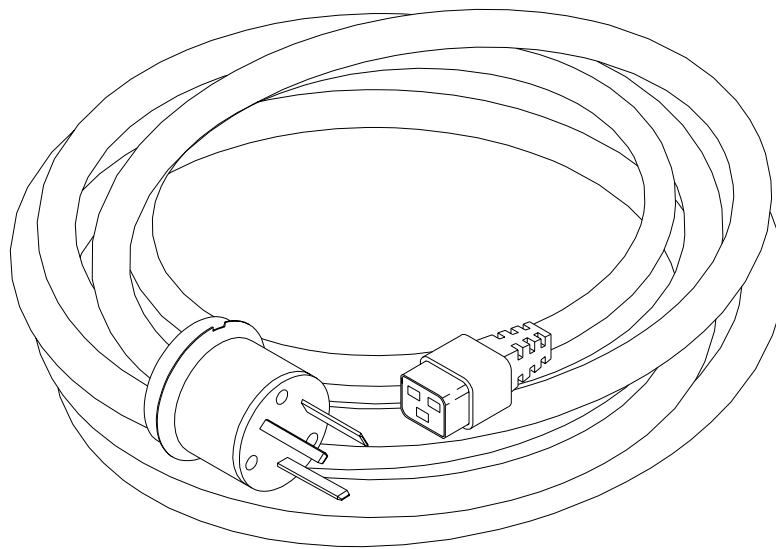

## Conversion Factors and Formulas

The conversion factors provided in this appendix are intended to ease data calculation for systems that do not conform specifically to the configurations listed in this Site Preparation Guide. Listed below are the conversion factors used in this document, as well as additional conversion factors which might be helpful in determining those factors required for site planning.

### Conversion Factors

- Refrigeration
  - 1 watt = .86 kcal/h
  - 1 watt = 3.412 Btu/h
  - 1 watt =  $2.843 \times 10^{-4}$  tons
  - 1 ton = 200 Btu/min.
  - 1 ton = 12,000 Btu/h
  - 1 ton = 3,517.2 W
- Metric Equivalents
  - 1 centimeter = 0.3937 in.
  - 1 meter = 3.28 ft
  - 1 meter = 1.09 yd
  - 1 in. = 2.54 cm
  - 1 ft = 0.305 m
  - 1 CFM = 1.7m<sup>3</sup>/h
- kVA Conversions
  - Three phase
  - $kVA = V \times A \times \sqrt{3} / 1000$
- Single phase
  - $kVA = V \times A / 1000$

### Formulas

- $kVA = \text{Voltage} \times \text{Current (amps)}$
- $\text{Watts} = VA \times PF$
- $\text{Btu} = \text{Watts} \times 3.41$

## Example of an Installation Schedule

The following schedule lists the sequence of events for a typical system installation:

- 60 days before installation
  - Floor plan design completed and mailed to HP (if required to be an HP task)
- 30 days before installation
  - Primary power and air conditioning installation completed
  - Telephone and data cables installed
  - Fire protection equipment installed
  - Major facility changes completed
  - Special delivery requirements defined
  - Site inspection survey completed
  - Delivery survey completed
  - A signed copy of the site inspection and delivery survey mailed to HP
  - Site inspection and predelivery coordination meeting arranged with an HP representative to review the inspection checklist and arrange an installation schedule.
- 7 days before installation
  - Final check made with an HP site preparation specialist to resolve any last minute problems

---

**NOTE**

Not all installations follow a schedule like the one noted. Sometimes, a server is purchased through another vendor which can preclude a rigid schedule. Other conditions could also prevent following this schedule. For those situations, consider a milestone schedule.

- Site Preparation – schedule with the customer as soon as possible after the order is placed
  - Site Verification – schedule with the customer a minimum of one to two days before the product is scheduled to be installed
-

## Sample Site Inspection Checklist

**Table 2-5 Customer and HP Information**

Customer Information	
Name:	Phone Number:
Street Address:	City or Town:
State or Province:	Country
Zip or postal code:	
Primary customer contact:	Phone Number:
Secondary customer contact:	Phone Number:
Traffic coordinator:	Phone Number:
Hewlett-Packard information	
Sales representative	Order Number:
Representative making survey	Date:
Scheduled delivery date	

**Table 2-6 Site Inspection Checklist**

Please check either Yes or No. If No, include comment or date				Comment or Date
Computer room				
No.	Area or condition	Yes	No	
1.	Is there a completed floor plan?			
2.	Is there adequate space for maintenance needs? Front 36 in (91.4 cm) minimum, rear 36 in. (91.4 cm) minimum are recommended clearances.			
3.	Is access to the site or computer room restricted?			
4.	Is the computer room structurally complete? Expected date of completion?			
5.	Is a raised floor installed and in good condition?			
6.	Is the raised floor adequate for equipment loading?			

**Table 2-6 Site Inspection Checklist (Continued)**

Please check either Yes or No. If No, include comment or date				Comment or Date
7.	Are there channels or cutouts for cable routing?			
8.	Is there a network line available?			
9.	Is a telephone line available?			
10.	Are customer supplied peripheral cables and LAN cables available and of the proper type?			
11.	Are floor tiles in good condition and properly braced?			
12.	Is floor tile underside shiny or painted? If painted, judge the need for particulate test.			
Power and lighting				
No.	Area or condition	Yes	No	
13.	Are lighting levels adequate for maintenance?			
14.	Are there AC outlets available for servicing needs? (for example, laptop)			
15.	Does the input voltage correspond to equipment specifications?			
15A	Is dual source power used? If so, identify type(s) and evaluate grounding.			
16	Does the input frequency correspond to equipment specifications?			
17.	Are lightning arrestors installed inside the building?			
18.	Is power conditioning equipment installed?			
19.	Is there a dedicated branch circuit for equipment?			
20.	Is the dedicated branch circuit less than 75 feet (22.86 meters)?			
21.	Are the input circuit breakers adequate for equipment loads?			
Safety				
No.	Area or condition	Yes	No	
22.	Is there an emergency power shut-off switch?			
23.	Is there a telephone available for emergency purposes?			



**Table 2-6 Site Inspection Checklist (Continued)**

Please check either Yes or No. If No, include comment or date				Comment or Date
24.	Is there a fire protection system in the computer room?			
25.	Is antistatic flooring installed?			
26.	Are there any equipment servicing hazards (loose ground wires, poor lighting, and so on.)?			
Cooling				
No.	Area or condition	Yes	No	
27.	Can cooling be maintained between 5°C and 35°C (up to 5000 ft.)? Derate 1 °C/1000 ft. above 5000 ft. and up to 10,000 ft.			
28.	Can temperature changes be held to 5 °C per hour with tape media? Can temperature changes be held to 20 °C per hour without tape media?			
29.	Can humidity level be maintained at 40% to 55% at 35 °C noncondensing?			
30.	Are air conditioning filters installed and clean?			
Storage				
No.	Area or condition	Yes	No	
31.	Are cabinets available for tape and disc media?			
32.	Is shelving available for documentation?			
Training				
No.	Area or Condition			
33.	Are personnel enrolled in the System Administrator's Course?			
34.	Is on-site training required?			

## Delivery Survey

The delivery survey forms list delivery or installation requirements. If any of the items on the list apply, enter the appropriate information in the areas provided on the form.

Special instructions or recommendations should be entered on the special instructions or recommendations form. The following list gives examples of special instructions or issues:

- Packaging restrictions at the facility, such as size and weight limitations
- Special delivery procedures
- Special equipment required for installation, such as tracking or hoists
- What time the facility is available for installation (after the equipment is unloaded)
- Special security requirements applicable to the facility, such as security clearance

**Figure 2-16 Delivery Survey (Part 1)**

DELIVERY CHECKLIST	
<b>DOCK DELIVERY</b>	
Is dock large enough for a semitrailer? Yes _____ No _____	
Circle the location of the dock and give street name if different than address.	
<div style="display: flex; justify-content: space-between; align-items: center;"><div style="text-align: center;">North</div><div style="border: 1px solid black; width: 150px; height: 60px; background-color: #cccccc;"></div><div style="text-align: center;">East</div></div> <div style="display: flex; justify-content: space-between; align-items: center; margin-top: 5px;"><div style="text-align: center;">West</div><div style="text-align: center;">South</div></div>	
<b>STREET DELIVERY</b>	
Circle the location of access door and list street name if different than address.	
<div style="display: flex; justify-content: space-between; align-items: center;"><div style="text-align: center;">North</div><div style="border: 1px solid black; width: 150px; height: 60px; background-color: #cccccc;"></div><div style="text-align: center;">East</div></div> <div style="display: flex; justify-content: space-between; align-items: center; margin-top: 5px;"><div style="text-align: center;">West</div><div style="text-align: center;">South</div></div>	
List height _____ and width _____ of access door.	
List special permits (if required) for street delivery.	
Permit type:	Agency obtained from:
_____	_____
_____	_____

60SP018A  
12/7/99

**Figure 2-17**      **Delivery Survey (Part 2)**

**ELEVATOR**

Fill in the following information if an elevator is required to move equipment.

Capacity (lb or kg) \_\_\_\_\_

Depth \_\_\_\_\_

Height \_\_\_\_\_

Width \_\_\_\_\_

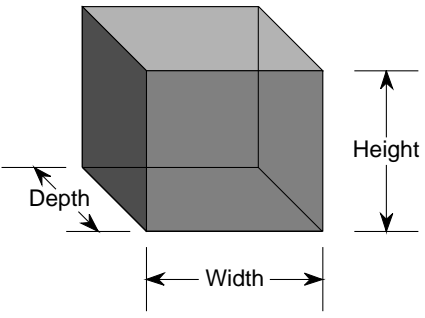

**STAIRS**

Please list number of flights and stairway dimensions.

Number of flights \_\_\_\_\_

Width \_\_\_\_\_

Width \_\_\_\_\_

Number of flights \_\_\_\_\_

Width \_\_\_\_\_

Width \_\_\_\_\_

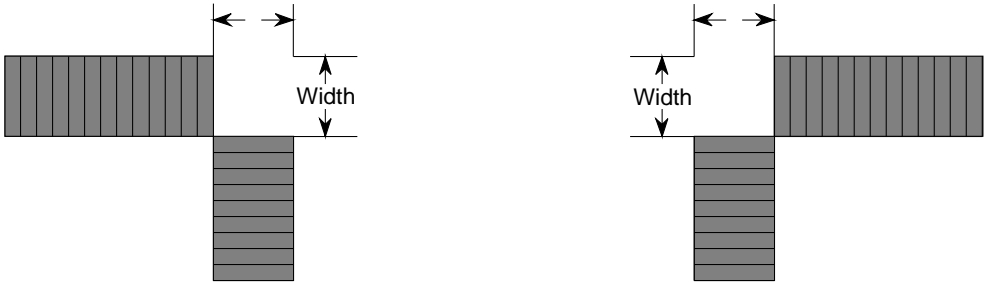

60SP019A  
11/24/99

## Site Preparation Glossary

### A-B

**Apparent power** A value of power for AC circuits that is calculated as the product of RMS current times RMS voltage, without taking the power factor into account.

**ASHRAE Standard 52-76** Industry standard for air filtration efficiency set forth by the American Society of Heating, Refrigerating, and Air-Conditioning Engineers, Inc.

**ASL** Above sea level.

**board** A printed circuit assembly (PCA). Also called a card or adapter.

**Btu/h** The abbreviation for British thermal units. The amount of heat required to raise one pound of water one degree fahrenheit per hour, a common measure of heat transfer rate.

### C

**CompactPCI** The newest specification for PCI-based industrial computers is called CompactPCI. It is electrically a superset of desktop PCI with a different physical form factor. See <http://www.picmg.org/compactpci.stm> for details.

**CFM** The abbreviation for cubic feet per minute, commonly used to measure the rate of air flow in an air conditioning system.

**Chilled water system** A type of air conditioning system that has no refrigerant in the unit itself. The refrigerant is contained in a chiller, which is located remotely. The chiller cools water, which is piped to the air conditioner to cool the space.

### D-K

**Dehumidification** The process of removing moisture from the air within a critical space.

**Derate** To lower the rated capability of an electrical or mechanical apparatus.

**Downflow** Refers to a type of air conditioning system that discharges air downward, directly beneath a raised floor, commonly found in computer rooms and modern office spaces.

**EIA unit** The Electronic Industries Association (EIA) defines this unit of measurement to be 1.75 inches in height. So then, 1U equals 1.75 inches (1U equals 44.45 mm).

**Humidification** The process of adding moisture to the air within a critical space.

**Inrush current** The peak current flowing into a power supply the instant AC power is applied. This peak is usually much higher than the typical input current due to the charging of the input filter capacitors. When switching power supplies are first turned on, they present high initial currents as a result of filter capacitor impedance. These large filter capacitors act like a short circuit, producing an immediate inrush surge current with a fast rise time. The peak inrush current can be several orders of magnitude greater than the typical current of the power supply.

**KVA** Abbreviation for kilovolt-amperes. (1000 x volt-amperes)

## L-N

**Latent cooling capacity** An air conditioning systems capability to remove heat from the air.

**Leakage current** A term relating to current flowing between the AC supply wires and earth ground. The term does not necessarily denote a fault condition. In power supplies, leakage current usually refers to the 60 Hertz current, which flows through the EMI filter capacitors that are connected between the AC lines and ground.

**Maximum input current** The operating current of the product equal to the maximum load divided by the minimum input voltage.

**NEBS** All electronic equipment has the potential to interfere with other electronic equipment. Interference can be caused by electromagnetic radiation, the grounding system, the electrical power connection, excessive heat or blocking the natural airflow, and connecting wires or cables. The Federal Communications Commission (FCC) regulates a portion of this problem through Part 15 of their rules and regulations. Even more stringent than the FCC Part 15 requirements, Network Equipment Building Standards (NEBS) covers a large range of requirements including criteria for personnel safety, protection of property, and operational continuity. The documents cover both physical requirements including: Space Planning, Temperature, Humidity, Fire, Earthquake, Vibration, Transportation, Acoustical, Air Quality and Illumination; and electrical criteria including: Electrostatic Discharge (ESD), Electromagnetic Interference (EMI), Lightning and AC Power Fault, Steady State Power Induction, Corrosion, DC Potential Difference, Electrical Safety, and Bonding and Grounding.

## O-R

**PCA** Abbreviation for Printed Circuit Assembly also referred to as a Printed Circuit Board (PCB).

**PCI** Currently, the most popular local I/O bus, the Peripheral Component Interconnect (PCI) bus was developed by Intel and introduced in 1993.

**PICMG** A consortium of companies involved in utilizing PCI for embedded applications. The PCI Industrial Computer Manufacturers Group (PICMG) controls the PICMG specification.

**Power factor** The ratio of true power to apparent power in an AC circuit. In power conversion technology, power factor is used in conjunction with describing the AC input current to the power supply.

**RMS** Root-mean-square (rms) refers to the most common mathematical method of defining the effective voltage or current of an AC wave. To determine rms value, three mathematical operations are carried out on the function representing the AC waveform: (1) The square of the waveform function (usually a sine wave) is determined. (2) The function resulting from step (1) is averaged over time. (3) The square root of the function resulting from step (2) is found.

## S-T

**Theoretical maximum power consumption** Represents the maximum wattage of a given configuration, assuming worst-case conditions (thermal tolerances, workloads, and so forth) on all system components. It is extremely unlikely that any customer will experience this level of power consumption.

**Tonnage** The unit of measure used in air conditioning to describe the heating or cooling capacity of a system. One ton of heat represents the amount of heat needed to melt one ton (2000 lb) of ice in one hour. 12,000 Btu/hr equals one ton of heat.

**True power** In an AC circuit, true power is the actual power consumed. It is distinguished from apparent power by eliminating the reactive power component that may be present.

**Typical input current** The operating current of the product measured using a typical load and target voltage.

**Typical power consumption** Represents the expected power consumption of a given configuration. The typical value is the approximate power consumption that a customer will most likely experience and can use for power budgeting purposes.

## U-Z

**Vapor seal** A vapor seal is an essential part of preventing moisture infiltration into or migration out of a critical space, such as a data processing center or other room that contains sensitive electronic instrumentation. Essentially, a vapor seal is a barrier that prevents air, moisture, and contaminants from migrating through tiny cracks or pores in the walls, floor, and ceiling into the critical space. Vapor barriers can be created using plastic film, vapor-retardant paint, vinyl wall coverings and vinyl floor systems, in combination with careful sealing of all openings (doors and windows) into the room.

**Watt** A unit of electricity consumption representing the product of amperage and voltage. When the power requirement of a product is listed in watts, you can convert to amps by dividing the wattage by the voltage (for example., 1200 watts divided by 120 V is 10 A)





**A**

air conditioning  
  system recommendations, 20  
air distribution system  
  room space return air, 21  
air ducts, 7  
  illustrated, 7  
average floor loading, 26

**B**

backplane  
  mass storage, 2  
  system, 2, 5  
basic air conditioning equipment requirements, 19  
basic air distribution systems, 20

**C**

cell board, 2, 5  
circuit breaker, 13  
component  
  power requirements, 3  
computer room layout plan, 31  
computer room safety  
  fire protection, 12  
computer system  
  sample installation schedule, 38

**D**

data communications cables, 18  
dimensions and weights, 2  
DIMM  
  removing and replacing, 21  
disk, 22

**E**

electrical and environmental guidelines  
  air distribution system, 20  
  computer equipment grounds, 15  
  computer room safety  
    fire protection, 12  
  dust and pollution control, 22  
  electrical conduit ground, 15  
  grounding systems, 15  
  lighting requirements, 13  
  main building electrical ground, 15  
  power distribution safety grounding, 15  
  power panel grounds, 15  
  power quality, 13  
    sources of electrical disturbances, 13  
  system installation guidelines, 18  
electrical specifications, 3  
environmental elements, 19  
  acoustics, 24  
  air conditioning equipment requirements, 19  
  air conditioning recommendations, 20  
  air distribution systems, 20  
  computer room considerations, 19  
  dust and pollution control, 22  
  electrostatic discharge

  prevention, 23  
  humidity level, 22  
  static protection measures, 24  
equipment footprint templates, 30  
ESD, 23

**F**

facility characteristics, 25  
facility guidelines  
  characteristics, 25  
  computer room layout, 31  
  equipment footprint templates, 30  
  floor loading terms, 25  
  operational space requirements, 28  
  typical raised floor site, 26  
  windows, 27  
fire protection, 12  
floor loading  
  raised floor, 25

**G**

grounding systems, 15  
  electrical conduit ground, 15

**H**

humidity level, 22

**K**

Keystone system  
  air ducts, 7  
  computer room layout, 31  
  environmental elements, 19  
  power system protection, 14

**M**

main building electrical ground, 15  
mass storage backplane, 2

**N**

noise emission specifications, 6

**O**

operating environment, 5

**P**

power cords, 3  
power distribution hardware, 14  
power distribution safety grounding, 15  
power distribution system  
  distribution hardware, 14  
power quality, 13  
power requirements  
  component, 3  
power system protection, 14  
power wiring, 14

---

# Index

## R

raised floor  
ground system, illustrated, 17

## S

sources of electrical disturbances, 13  
space requirements, 28  
computer room layout, 31  
delivery space requirements, 28  
equipment footprint templates, 30  
system backplane, 2, 5  
system installation guidelines, 18  
data communications cables, 18  
wiring connections, 18  
system specifications, 1

## T

typical installation schedule, 38

## W

wiring  
connections, 18