

HP SureStore DLT Autoloader Models 418, 718 & 818

User's Guide

Edition 1



Manufacturing Part Number: C6282-90009

September 1999

Printed in: Greeley, CO USA

© Copyright 1999 Hewlett-Packard Company

Notice

This document contains information that is protected by copyright. All rights are reserved. No part of this document may be photocopied, reproduced, or translated to another language. The information contained in this document is subject to change without notice.

Hewlett-Packard makes no warranty of any kind with regard to this printed material, including, but not limited to the implied warranties of merchantability and fitness for a particular purpose. Hewlett-Packard shall not be liable for errors contained herein or for incidental or consequential damages in connection with the furnishing, performance, or use of this material.

See Appendix B for important safety and regulatory information.

Warranty

NOTE

See Appendix A for more information about support and service.

HP PRODUCT: HP SureStore DLT Autoloader Models 418, 718, and 818

DURATION OF LIMITED WARRANTY: 3 years

1. HP warrants HP hardware, accessories, and supplies against defects in materials and workmanship for the period specified above. If Hewlett-Packard receives notice of such defects during the warranty period, Hewlett-Packard will, at its option, either repair or replace products which prove to be defective. Replacement products may be either new or like-new.
2. HP warrants that HP software will not fail to execute its programming instructions, for the period specified above, due to defects in material and workmanship when properly installed and used. If HP receives notice of such defects during the warranty period, HP will replace software media that does not execute its programming instructions due to such defects.

3. HP does not warrant that the operation of HP products will be uninterrupted or error free. If HP is unable, within a reasonable time, to repair or replace any product to a condition as warranted, customer will be entitled to a refund of the purchase price upon prompt return of the product.
4. HP products may contain remanufactured parts equivalent to new in performance or may have been subject to incidental use.
5. The warranty period begins on the date of delivery or on the date of installation if installed by HP. If customer schedules or delays HP installation more than 30 days after delivery, warranty begins on the 31st day from delivery.
6. Warranty does not apply to defects resulting from (a) improper or inadequate maintenance or calibration, (b) software, interfacing, parts or supplies not supplied by HP, (c) unauthorized modification or misuse, (d) operation outside of the published environmental specifications for the products, or (e) improper site preparation or maintenance.
7. TO THE EXTENT ALLOWED BY LOCAL LAW, THE ABOVE WARRANTIES ARE EXCLUSIVE AND NO OTHER WARRANTY OR CONDITION, WHETHER WRITTEN OR ORAL, IS EXPRESSED OR IMPLIED AND HP SPECIFICALLY DISCLAIMS ANY IMPLIED WARRANTIES OR CONDITIONS OF MERCHANTABILITY, SATISFACTORY QUALITY, AND FITNESS FOR A PARTICULAR PURPOSE.
8. HP will be liable for damage to tangible property per incident up to the greater of \$300,000 or the actual amount paid for the product that is the subject of the claim, and for damages for bodily injury or death, to the extent that all such damages are determined by a court of competent jurisdiction to have been directly caused by a defective HP product.
9. TO THE EXTENT ALLOWED BY LOCAL LAW, THE REMEDIES IN THIS WARRANTY STATEMENT ARE THE CUSTOMER'S SOLE AND EXCLUSIVE REMEDIES. EXCEPT AS INDICATED ABOVE, IN NO EVENT WILL HP OR ITS SUPPLIERS BE LIABLE FOR LOSS OF DATA OR FOR DIRECT, SPECIAL, INCIDENTAL, CONSEQUENTIAL (INCLUDING LOST PROFIT OR DATA), OR OTHER DAMAGE, WHETHER BASED IN CONTRACT, TORT, OR OTHERWISE.

Printing History

New editions of this manual incorporate all material updated since the previous edition. The manual printing date and part number indicate the current edition. The printing date changes when a new edition is printed. (Minor corrections and updates incorporated at reprint do not change this date.)

Edition 1: September 1999: Initial printing

Typographical Conventions and Terms

The following typographical conventions are used in this manual:

Italic font: Denotes important information.

Keycap : Keys on the Autoloader.

Computer Output: Information displayed in the control panel and screen menu items that you select.

Menu Path: Series of menus that you need to enter to access the menu currently being described.

WARNING

Warnings call attention to a procedure or practice that could result in personal injury if not correctly performed. Do not proceed until you fully understand and meet the required conditions.

CAUTION

Cautions call attention to an operating procedure or practice that could damage the product if not correctly performed. Do not proceed until understanding and meeting these required conditions.

NOTE

Notes provide information that can be helpful in understanding the operation of the product.

In This Manual

In this manual, the following areas are described:

- | | |
|------------|---|
| Chapter 1 | Getting Started: Describes how to install, connect, power on, and move the Autoloader. |
| Chapter 2 | Operating the Autoloader: Describes how to operate the control panel, set administrative options, and troubleshoot. |
| Chapter 3 | Using and Maintaining Tapes: Describes how to use and care for tapes. |
| Appendix A | Support and Customer Service: Describes how to get support for the Autoloader and how to order parts. |
| Appendix B | Safety and Regulatory: Describes safety and regulatory information for the Autoloader. |
| Appendix C | TapeAlert Messages: Describes the TapeAlert messages. |
| Appendix D | Installing an Autoloader Into a Non-HP Rack: Describes how to install the Autoloader into a non-HP rack. |

Contents

1. Getting Started

Chapter Overview	1-2
Product Components	1-3
Installation Overview	1-4
Autoloader Rear Panel	1-5
Choosing a Location	1-6
Mounting the Autoloader in a Rack	1-7
Tools and Components.....	1-7
Mounting the Autoloader	1-8
Connecting the Autoloader.....	1-15
Powering on the System	1-18
Installing the SCSI Bus Adapter	1-19
Moving or Shipping the Autoloader.....	1-20
Moving the Autoloader.....	1-20
Shipping the Autoloader	1-22

2. Operating the Autoloader

Chapter Overview	2-2
Loading/Unloading Tapes.....	2-3
Inserting and Removing Tapes with Software	2-3
Opening the Door	2-3
Alternate Door Open Method.....	2-3
Removing the Magazine	2-4
Inserting the Magazine	2-5
Loading Tapes	2-5
Unloading Tapes	2-7
Autoloader Control Panel.....	2-8

Contents

Understanding Control Panel Messages	2-9
Tape Status	2-9
Drive/Autoloader Status	2-10
Autoloader Display Menu Tree.....	2-11
Top-Level Menu Options	2-12
Password-Protected Functions	2-15
Entering the Administration Menu Password.....	2-17
Changing the Administration Menu Password	2-18
Setting or Viewing SCSI IDs	2-19
Setting SCSI IDs.....	2-19
Viewing SCSI IDs	2-20
Cleaning the Autoloader Tape Drive.....	2-21
Drive Cleaning Errors.....	2-23
Configuring the Autoloader	2-24
Retrieving Autoloader Information	2-27
Running an Internal Test	2-28
Upgrading Firmware.....	2-33
Upgrading Drive Firmware from Tape	2-33
Troubleshooting.....	2-34
Understanding Error Messages.....	2-42
3. Using and Maintaining Tapes	
Chapter Overview	3-2
Labeling Tape Cartridges	3-3
Labeling the Magazine.....	3-4

Contents

Write-Protecting Tape Cartridges	3-5
Maintaining Tape Cartridges.....	3-6
Do Not:.....	3-6
Do:.....	3-6
Inspecting Tape Cartridges.....	3-7
DO NOT Use Cartridges:.....	3-8
A. Support and Customer Service	
Supplies and Accessories.....	A-2
Hewlett-Packard Customer Support	A-3
Information Needed for Support	A-3
Faxback Services	A-4
Hewlett-Packard Web Site.....	A-4
Telephone Support During Warranty.....	A-5
North and South America	A-5
European Customer Support Centers	A-5
Asia Pacific Customer Support Centers	A-7
Elsewhere.....	A-7
Telephone Support After Warranty.....	A-8
US and Canada	A-8
Europe	A-8
Elsewhere.....	A-8
HP Reseller Locator Numbers	A-8
B. Safety and Regulatory	
Chapter Overview.....	B-2
Regulatory Information.....	B-3
United Kingdom Telecommunications Act 1984	B-4

Contents

Herstellerbescheinigung.....	B-4
English Translation of German Sound Emission Directive	B-4
Japanese Harmonics Statement	B-5
Japanese VCCI Class B Statement.....	B-5
English Translation	B-5
Taiwan Class A Warning Statement.....	B-6
For HP DLT Library Model 718 (C6282L, C6280J, A5501A) B-6	
Taiwan Class A Warning Statement.....	B-6
For HP DLT Library Model 418 (C6280F and C6280H)	B-6

C. TapeAlert Messages

Overview	C-2
TapeAlert Messages and Descriptions	C-3

D. Installing an Autoloader into a Non-HP Rack

Mounting the Autoloader in a Non-HP Rack.....	D-2
Tools and Components.....	D-2
Mounting the Autoloader	D-3
Cable Management.....	D-9

Figures

Figure 1-1. Rear Panel Features	1-5
Figure 1-2. Rack Kit Parts	1-7
Figure 1-3. Clipnut and Screw Installation	1-8
Figure 1-4. Installation With Space Above Bezel	1-9
Figure 1-5. Installation Without Space Above Bezel	1-9
Figure 1-6. Shelf Installation	1-10
Figure 1-7. Filler Panel Installation	1-11
Figure 1-8. Removing the Cover and Feet	1-12
Figure 1-9. Securing the Autoloader	1-13
Figure 1-10. Cable Management.	1-14
Figure 1-11. Autoloader as the Only Peripheral	1-16
Figure 1-12. Autoloader with Other Peripherals.	1-17
Figure 1-13. Unbolting the Autoloader	1-21
Figure 2-1. Removing the Magazine.	2-4
Figure 2-2. Loading Tapes into the Magazine	2-5
Figure 2-3. Loading Internal Slots	2-6
Figure 3-1. Label Position	3-3
Figure 3-2. Magazine Label Position	3-4
Figure 3-3. Write-Protect Button Settings.	3-5
Figure 3-4. Leader Buckling Loop	3-7
Figure D-1. Rack Kit Parts	D-2
Figure D-2. Clipnut and Screw Installation.	D-3
Figure D-3. Customizing the Shelf Depth	D-4

Figures

Figure D-4. Shelf Installation	D-5
Figure D-5. Tighten the Screws.	D-6
Figure D-6. Filler Panel Installation.	D-7
Figure D-7. Securing the Autoloader	D-8
Figure D-8. Cable Management	D-9

Tables

Table 1-1. Components Provided	1-3
Table 1-2. Location Criteria	1-6
Table 1-3. Technical Specifications.....	1-6
Table 2-1. Top-Level Menus	2-12
Table 2-2. Admin Menu Options	2-15
Table 2-3. Drive Cleaning Troubleshooting	2-23
Table 2-4. Configuration Options	2-24
Table 2-5. Information Logs	2-27
Table 2-6. Tests Available from the Control Panel.....	2-28
Table 2-7. Troubleshooting Table	2-32
Table 2-8. Common Error Codes.....	2-41
Table C-1. TapeAlert Tape Drive Error Messages.....	C-3
Table C-2. TapeAlert Tape Library Error Messages	C-7

Tables

1 **Getting Started**

Chapter Overview

This chapter explains the following:

- Identifying product components
- Choosing a location
- Installing the Autoloader
- Connecting the Autoloader
- Powering on the system
- Installing the SCSI bus adapter
- Moving the Autoloader
- Shipping the Autoloader

Product Components

Table 1-1 describes the parts that are provided with the Autoloader.

Table 1-1

Components Provided

Product Name	Description
SCSI cables	Connects the Autoloader to the host. Cable length is 2 meters.
SCSI terminator	68-pin terminator terminates power at the end of a SCSI chain.
SCSI jumper cable	Connects the drive and SCSI controller board.
SCSI bus adapter	Matches the interface type of the Autoloader.
Power cord	Localized power cord supplies power.
Data cartridges	Five type IV DLTtape™ cartridges for data backup.
Cleaning cartridge	One cartridge included for cleaning the tape drive head.
Installation poster	Displays simplified installation instructions.
Live trial software	One shrink-wrapped package for trial use. Contact software vendor for licensing information.
User's Guide	Contains installation, operation, and troubleshooting information.
SureStore Tape CD-ROM	Contains diagnostic utilities, backup software information, and localized versions of the user's guide and installation poster.

Installation Overview

Before installing the Autoloader:

- Make sure you have the components listed in Table 1-1 on page 1-3.
- Become familiar with the back of the Autoloader, as shown in Figure 1-1 on page 1-5.

Installing the Autoloader requires:

1. Choosing a suitable location.
2. Mounting the Autoloader in a rack (rackmount configuration only).
3. Connecting the Autoloader.
4. Powering on the system.

These steps are explained in this chapter.

NOTE

After unpacking the Autoloader, save the shipping carton and accessory kit carton. These items may be reused if future shipping becomes necessary.

Autoloader Rear Panel

Figure 1-1 Rear Panel Features

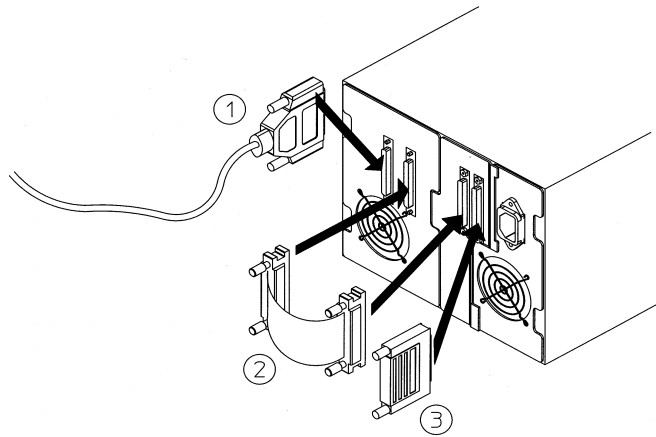

1	SCSI cable connector to host SCSI port
2	SCSI jumper cable
3	SCSI terminator

The Autoloader can be connected to the host system in one of two configurations:

Standard

configuration: Connects the drive and the Autoloader with an external jumper cable on one SCSI bus, as shown in Figure 1-1.

Advanced

configuration: Connects the drive and autoloader controller to the host using separate SCSI buses.

NOTE

The advanced configuration requires an additional terminator that is not provided.

Choosing a Location

Choose a location that meets the following criteria:

Table 1-2

Location Criteria

Room temperature	50–104° F (10–40 C)
Power source	AC power voltage: 100–127V or 200–240V Auto Ranging Current Rating: 100–127V, 1.8A, 50/60 HZ, 220–240V, .9A, 50/60 HZ Auto Ranging Maximum Watts: 100 Watts, 100-127V (60 HZ) Maximum Watts: 90 Watts, 200-240V (50 HZ)
Air quality	Minimal particulate contamination. Avoid areas near frequently used doors and walkways, stacks of supplies that collect dust, smoke-filled rooms, large or high-speed printers. Do not use filters. <i>Caution:</i> Excessive dust and debris can damage the tapes and the tape drive.
Adequate clearance	Desktop configuration—free standing: Back 6 inches/ 15 cm Front 8 inches/ 20 cm Sides 1 inch/ 2.5 cm Rackmount configuration—requires 5 EIA units in a rack (1 EIA = 1.75 inches or 4.5 mm)

Table 1-3

Technical Specifications

Dimensions	Height: 7.35 inches (18.7 cm) Width: 8.9 inches (22.6 cm) Depth: 22 inches (55.9 cm) Weight: 31.5 pounds (14.3 kg)
Acoustics	58 Decibels Sound Pressure

Mounting the Autoloader in a Rack

NOTE

For instructions on installing the Autoloader into a non-HP rack, refer to “Installing an Autoloader into a Non-HP Rack” on page D-1.

Tools and Components

Before you begin, make sure you have the following:

Tools:

#2 Phillips screwdriver

Kit Components (parts are labeled for easy identification):

- | | |
|-------------------------------------|---------------------------|
| 1. Installation poster (Qty 1) | 6. 10-32 clipnuts (Qty 8) |
| 2. Template (Qty 2) | 7. Support bezel (Qty 1) |
| 3. Cable ties (Qty 2) | 8. Filler panel (Qty 1) |
| 4. M4 x 10 mm pan phillips (Qty 4) | 9. Shelf (Qty 1) |
| 5. 10-32 x 5/8 pan phillips (Qty 8) | |

Figure 1-2

Rack Kit Parts

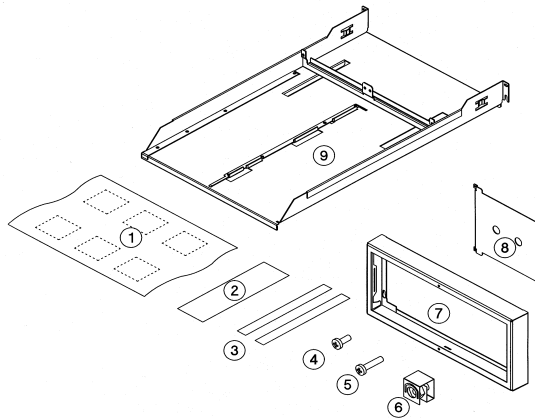

NOTE

The rack kit may contain extra parts.

Mounting the Autoloader

1. Facing the front of the rack and using the template as a guide, install four clipnuts (two in each rail) above any existing products (Figure 1-3).

TIP

For a level shelf, ensure that the screws are in the same position on the right and left rail.

NOTE

Your rack might look different from the illustrations.

2. Using the template as a guide, install two clipnuts into each back rail of the rack. The back lower clipnuts should be located in the same position as the lower clipnuts in the front of the rack (Figure 1-3).
3. Using six 10-32 screws (four in the front and two in the back lower clipnuts), start a screw into each clipnut and turn 2-3 times.

NOTE

If you are installing the unit flushed to the top of the rack, do not install screws at this time. Instead, proceed to the next step.

Figure 1-3 Clipnut and Screw Installation

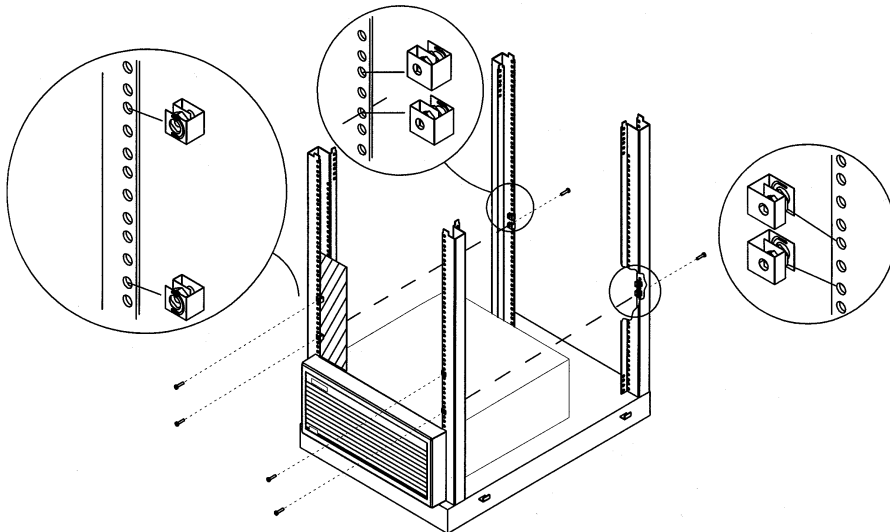

4. Position the holes on the support bezel over the screws on the clipnut, and slide downward, securing the bezel into place (Figure 1-4). If you are installing the Autoloader flushed to the top of the rack, hold the bezel in place, then install the screws (Figure 1-5). Tighten screws when complete.

Figure 1-4 Installation With Space Above Bezel

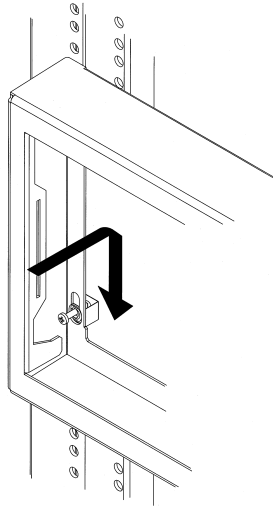
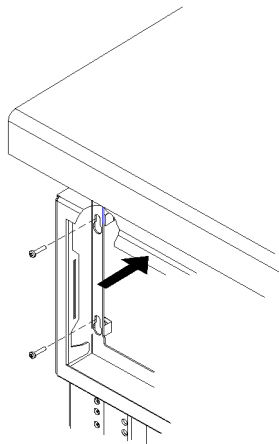

Figure 1-5 Installation Without Space Above Bezel



Getting Started

Installation Overview

5. Slide the shelf through the back of the rack until the front lip is over the bezel and the rear portion of the shelf slides over the back screws (Figure 1-6).
 - a. Lower the shelf into place, and tighten the screws in the bottom clipnuts.
 - b. Insert and tighten two additional screws into the top clipnuts to secure the shelf.

Figure 1-6 Shelf Installation

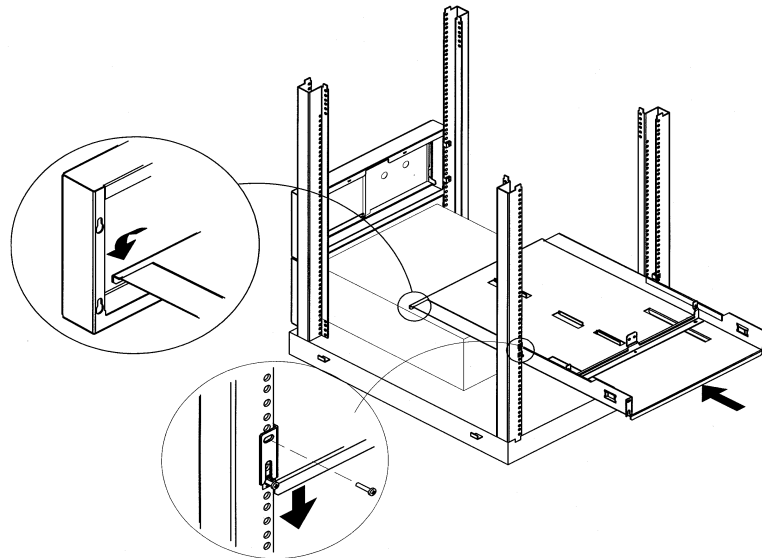

NOTE

Have a second person stand at the front of the rack to help guide the front lip of the shelf between the slots on the bezel.

CAUTION

Ensure that installation in your rack cabinet does not create an unstable condition.

6. Decide on the location for the Autoloader. The filler panel will be installed on the other side if you are only installing one Autoloader (Figure 1-7).
 - a. Reach inside the bezel and insert the filler panel into the slot on the bezel.
 - b. Pull the filler panel forward to the inside face of the bezel until it snaps into position.

Figure 1-7 Filler Panel Installation

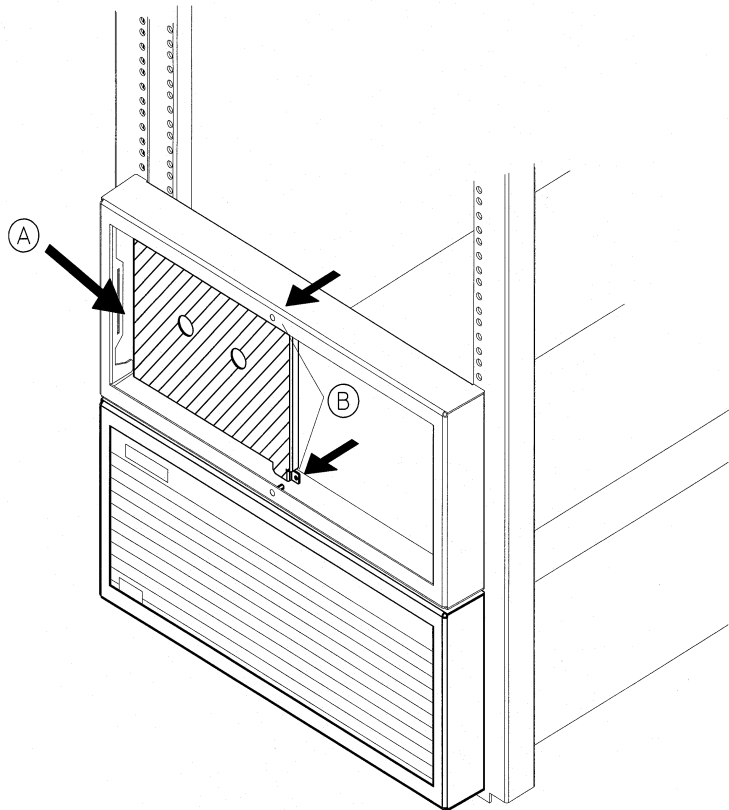

Getting Started

Installation Overview

7. Remove the cover and feet on the Autoloader.
 - a. Remove the four screws on the back of the cover and the two screws on the side of the cover (Figure 1-8).
 - b. Remove the cover by pulling the sides of the cover out and lifting it up.

NOTE

The cover may fit tightly near the control panel. If the cover is not easily removed, pull the sides out near the control panel while lifting up on the back end of the cover.

- c. Unscrew and remove the four feet. You may lay the unit on its side to remove the feet.

Figure 1-8 Removing the Cover and Feet

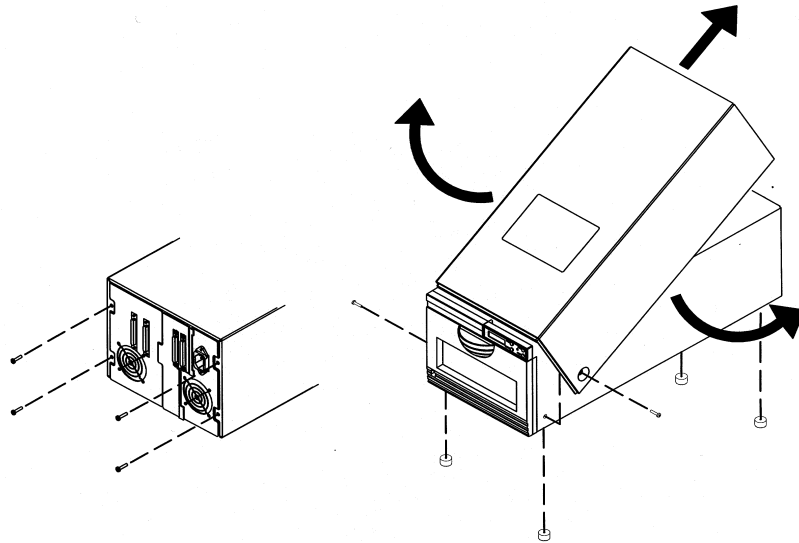

NOTE

If it later becomes necessary to ship the Autoloader, reattach the cover and feet before shipping.

8. From the front of the bezel, slide the Autoloader into the shelf until it rests firmly against the support bracket.

- Secure the unit by installing two M4x10 mm screws through the support bracket and into the rear panel (Figure 1-9).

Figure 1-9 **Securing the Autoloader**

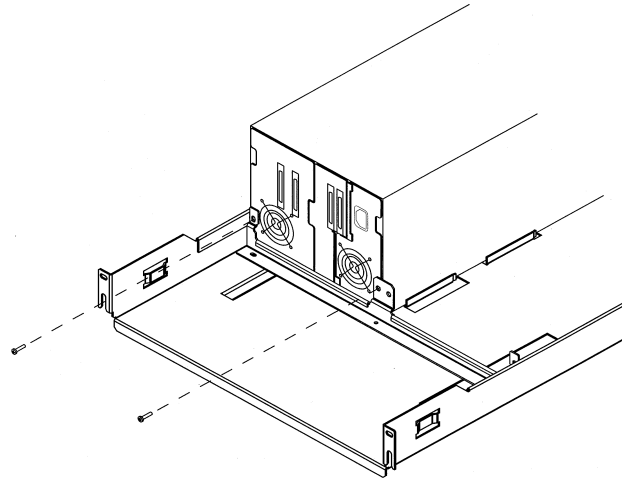

- After connecting the external cables, secure the cables to the side of the rack.

CAUTION

Ensure that the SCSI and power cables are properly routed and secured on rackmounted Autoloaders so that they do not interfere with other moveable rackmounted products. Failure to properly route cables could damage them.

- After connecting external cables described in “Connecting the Autoloader” on page 1-15, thread one cable tie through the cable tie mount on the shelf (Figure 1-10 on page 1-14).
- Gently pull the cables toward the cable tie to secure them to the back of the shelf.
- Route the cables through the rack so that they do not interfere with other rackmounted products.

Figure 1-10 Cable Management

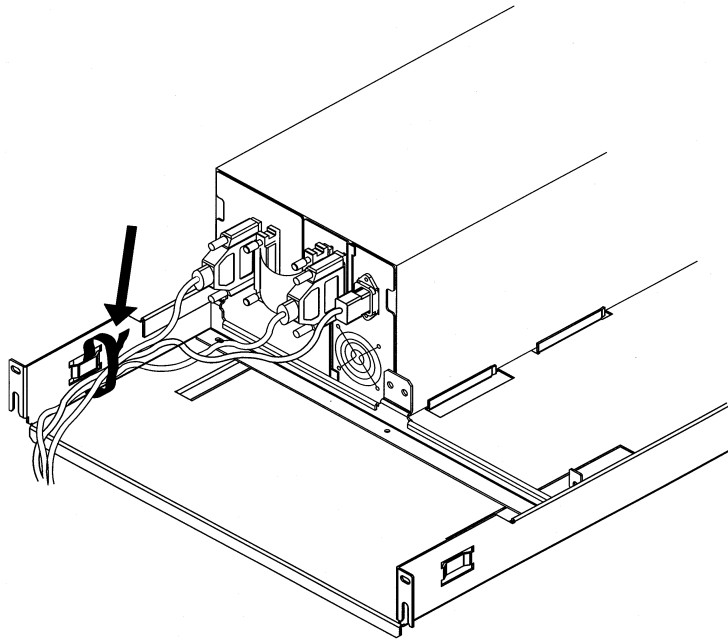

NOTE

Save the remaining screws for a possible second Autoloader installation.

CAUTION

Be certain that the temperature of the rack cabinet does not exceed the maximum temperature of 104°F or 40C.

Connecting the Autoloader

1. Properly shut down all peripheral devices connected to the host computer.

If the host computer is connected to a network, check with the system administrator before switching off power.

2. Shut down the host.

If the host does not already have a SCSI bus adapter with a matching interface type, install the supplied adapter. See “Installing the SCSI Bus Adapter” on page 1-19 for more information.

3. Connect the long SCSI cable from the Autoloader to the host.

NOTE

For maximum performance, do not connect the Autoloader to the same SCSI bus as the hard drive, another tape drive, or a SCSI RAID controller.

4. Connect the SCSI jumper cable to the two inside connectors on the Autoloader.

To install the Autoloader as the only device on the SCSI bus, connect the cables and terminator as shown in Figure 1-11 on page 1-16.

To install the Autoloader in the middle of a SCSI bus, connect the cables and terminator as shown in Figure 1-12 on page 1-17.

NOTE

If using a single-ended Autoloader with an HVDS host, you must use a single-ended to wide differential converter, such as HP part number C4316A converter. To install, connect a wide SCSI cable from the host differential SCSI port to the differential fast/wide input of the converter. Connect the single-ended output of the converter to the Autoloader.

Any converter used must be fully SCSI compliant.

Figure 1-11 Autoloader as the Only Peripheral

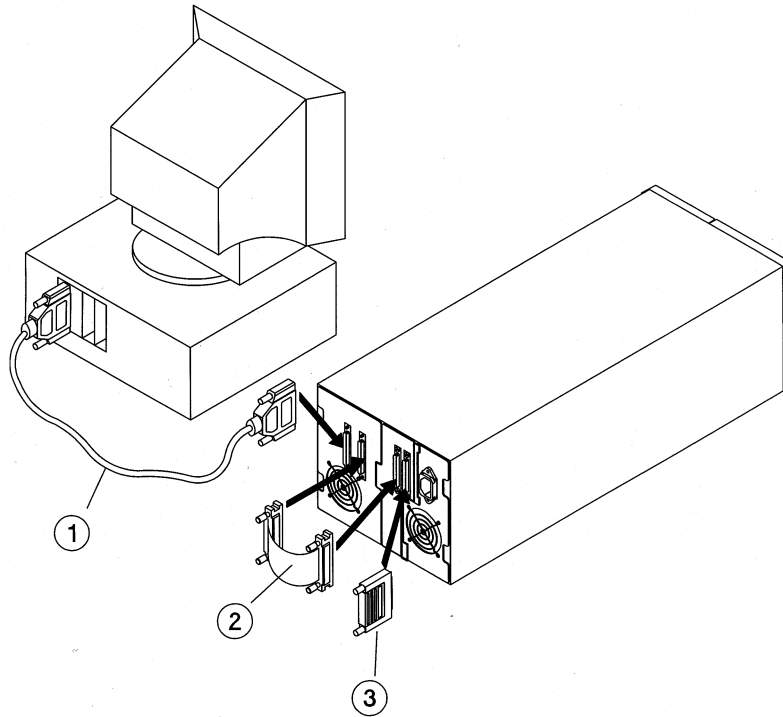

1	SCSI cable to host SCSI port
2	SCSI jumper cable
3	SCSI 68-pin terminator

Figure 1-12 Autoloader with Other Peripherals

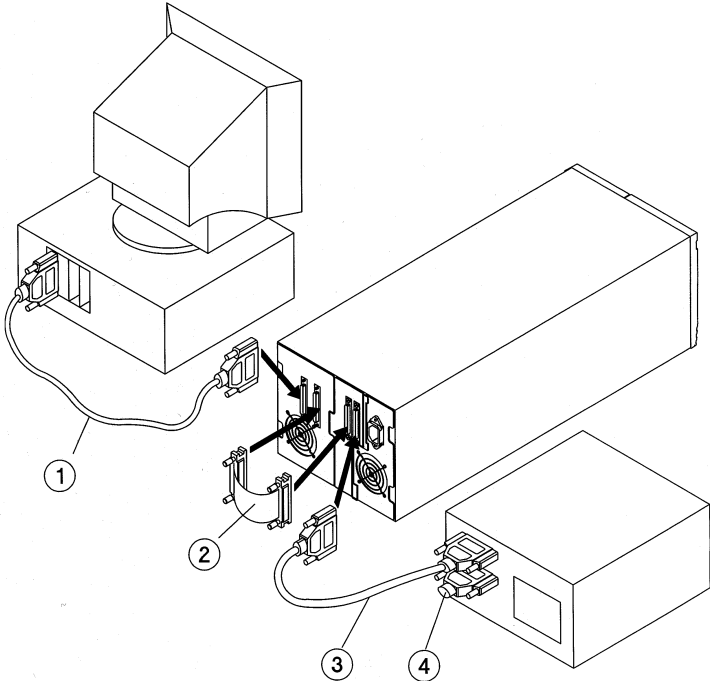

1	SCSI cable to host SCSI port
2	SCSI jumper cable
3	SCSI cable to SCSI port
4	SCSI 68-pin terminator

5. Verify the standby switch on the autoloader control panel is switched off. Connect the socket end of the power cord into the power port on the autoloader rear panel.
6. If you are mounting the unit in a rack, secure the cables to the side of the rack as shown in Figure 1-10 on page 1-14.
7. To power on the unit, see the instructions in “Powering on the System” on page 1-18.

Powering on the System

WARNING

To disconnect primary power, remove the power cord from the wall receptacle. The standby switch on the front of the unit shuts down secondary circuits only.

CAUTION

Make certain that reliable earth grounding of the rackmounted equipment and the power tap is maintained.

CAUTION

Be certain that the total current of the rack components does not exceed the current rating of the power tap or outlet receptacle.

1. Power off the host and other peripherals.
2. Connect the power cord into a grounded outlet.
3. If the standby switch is turned off, use a pencil eraser or other similar tool to switch it on (see “Autoloader Control Panel” on page 2-8).

Initially the messages NOT READY/SELF TEST, NOT READY/INVENTORY CHECK, and NOT READY/CHECK DRIVE will display on the front control panel. After the power-on test completes (approximately 30 seconds), the drive status information appears in the display window.

NOTE

If you have problems powering on the unit see “Troubleshooting” on page 2-32.

4. Turn on any other peripherals.
5. Turn on the host.

Installing the SCSI Bus Adapter

Refer to the host computer user's guide and the card installation instructions for information on installing the SCSI bus adapter.

Follow these guidelines:

- Make sure that the host has a PCI expansion slot available.
- Power off the host before installation.
- For maximum performance, do not connect other peripherals to the same SCSI bus as the hard drive.
- If you are using a SCSI bus adapter other than the one provided, ensure that it matches the Autoloader interface type as shown below.

Model	Part Number	Interface
418	C6280F	Single-Ended SCSI
718	C6280J	Single-Ended SCSI
818	C6282NB C6282RA	Low Voltage Differential SCSI (LVDS) High Voltage Differential SCSI (HVDS)

CAUTION

Do not connect an HVDS Autoloader on a single-ended SCSI bus.

LVDS Autoloaders require an LVDS terminator and can be used on a single-ended or low voltage differential SCSI bus.

The SCSI specification defines maximum cable lengths for LVDS as:

- 3 meters in single-ended fast/wide mode
- 6 meters in single-ended slow mode
- 12 meters in LVDS mode
- 1.5 meters if a single-ended ultra SCSI device is on the same bus

Moving or Shipping the Autoloader

Moving the Autoloader

1. Verify that a tape is not in the drive.
 - If the drive is loaded with a tape, unload it before moving the Autoloader. Refer to the backup software documentation, or use the UNLOAD menu option (see “Top-Level Menu Options” on page 2-12).
2. Shut down the host if necessary.

CAUTION

Notify the system administrator before shutting down the host.

3. Remove the power cord and the host SCSI cable from the autoloader rear panel.
 - If the Autoloader is a stand-alone unit, place it onto a cart and wheel it to its new location. Go to step 5.
 - If the Autoloader is rackmounted, follow these steps:
 - a. Remove the two screws that secure the back of the Autoloader to the shelf (Figure 1-13 on page 1-21).
 - b. Remove the filler panel (if necessary), and slide the Autoloader out of the rack.
 - c. Move the Autoloader to its new destination.
4. Reinstall the Autoloader into the rack using the rackmount kit instructions in “Mounting the Autoloader” on page 1-8.

NOTE

You will need the rack kit equipment to reinstall the unit into another rack (Figure 1-2 on page 1-7).

Figure 1-13 **Unbolting the Autoloader**

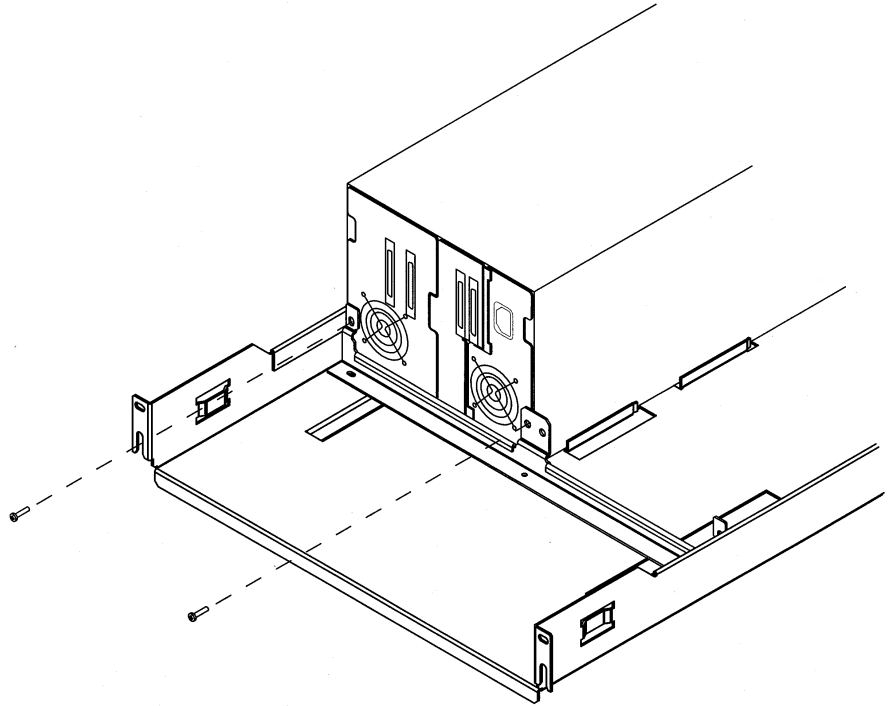

5. Reconnect the power cord and SCSI cables. See “Connecting the Autoloader” on page 1-15.

Shipping the Autoloader

1. Verify that a tape is not in the drive.
 - If the drive is loaded with a tape, unload it before moving the Autoloader. Refer to the backup software documentation, or use the UNLOAD menu option. See “Top-Level Menu Options” on page 2-12.
2. Remove all tape cartridges from the magazine and internal slots, and return the magazine to the Autoloader.
3. Shut down the host if necessary.

CAUTION

Notify the system administrator before shutting down the host.

4. Remove the power cord and the host SCSI cable from the rear panel.
 - If the Autoloader is a desktop unit, go to step 5.
 - If the Autoloader is rackmounted, follow these steps:
 - a. Remove the two screws that attach the Autoloader to the shelf (Figure 1-13 on page 1-21).
 - b. Remove the filler panel (if necessary), and slide the Autoloader out of a rack.

NOTE

You will need the rack kit equipment to reinstall the unit into another rack (Figure 1-2 on page 1-7).

5. Repackage the Autoloader in the original packing materials.

If the original packaging materials are not available, contact your service representative for packaging materials.

CAUTION

The Autoloader can be seriously damaged if it is not shipped using appropriate shipping materials.

2 **Operating the Autoloader**

Chapter Overview

This chapter explains how to:

- Load and remove tapes
- Load and remove the magazine
- Operate the control panel
- Interpret control panel messages
- Enter and change an administration menu password
- View and set SCSI IDs
- Clean the tape drive
- Interpret drive cleaning errors
- Configure the Autoloader
- Retrieve Autoloader information
- Run internal tests
- Upgrade firmware
- Troubleshoot
- Interpret common error messages

Loading/Unloading Tapes

Inserting and Removing Tapes with Software

If you are using a software application to manage tapes in the Autoloader, check the software documentation for instructions on inserting and removing them.

Opening the Door

1. Press the **NEXT** button until **RELEASE DOOR** is displayed in the control panel.
2. Press **ENTER**.
 - If the drive is empty, the door will release.
 - If a tape is loaded in the drive, **EMPTY DRIVE NO** is displayed. If the Autoloader is controlled with host software, press **ENTER** or **CANCEL** to abort. Use the host software to unload the drive.
 - Otherwise, press **NEXT** or **PREV** until **EMPTY DRIVE YES** is displayed, and then press **ENTER**.
UNLOADING DRIVE will be displayed for up to two minutes, followed by **DOOR RELEASED**.
3. Gently open the front access door by pulling down the handle.

Alternate Door Open Method

1. Press and hold the **CANCEL** button for three to five seconds.
2. After hearing a “click,” pull on the door handle to open.

Operating the Autoloader
Loading/Unloading Tapes

Removing the Magazine

1. Swing the magazine handle forward until it is perpendicular with the magazine (Figure 2-1).
2. Pull the magazine straight out.

Figure 2-1 **Removing the Magazine**

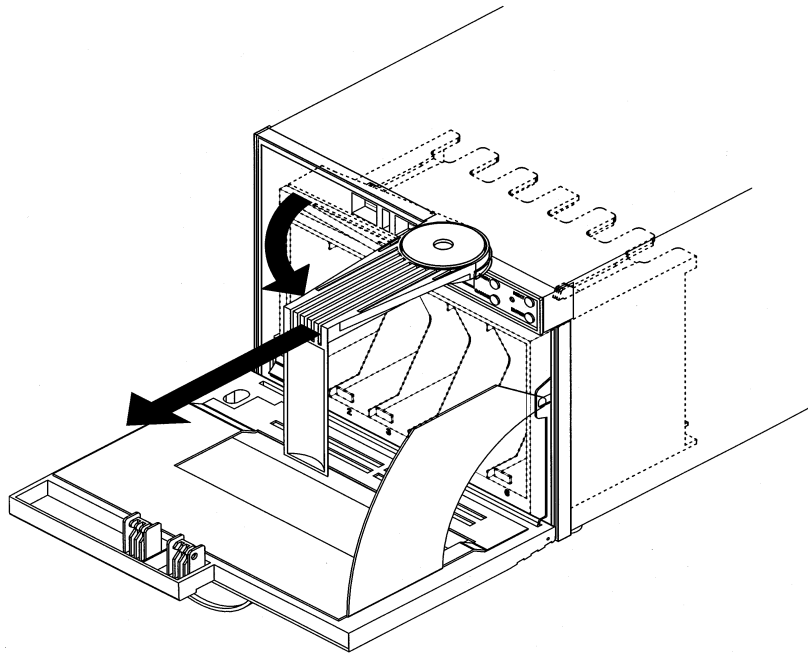

NOTE

Remove the magazine to load tapes. If tapes are loaded while the magazine is in the autoloader, tapes may not be secured inside the slot.

Inserting the Magazine

1. With the magazine handle facing out the front of the Autoloader, slide the magazine into the Autoloader until it “clicks” into place (Figure 2-1 on page 2-4).
2. Swing the magazine handle to the left to store.
3. Gently shut the front access door.

NOTE

The INVENTORY CHECK runs whenever the front access door closes so that an inventory of storage slot locations can be stored into memory. This process takes approximately thirty seconds. The inventory check will not run if the door is not completely shut, or if magazine is not completely inserted.

Loading Tapes

The Autoloader has two internal storage slots inside the unit (slot numbers 7 and 8) and six storage slots in the removable magazine (slot numbers 1-6).

1. With the write-protect switch facing out and at the top, load tapes into the magazine by pushing the tape in until it “clicks.” If the tape does not “click” into place and the magazine is inside the autoloader, remove the magazine to load the tape. A metal tab should release to lock the tape into place (Figure 2-2).

Figure 2-2 Loading Tapes into the Magazine

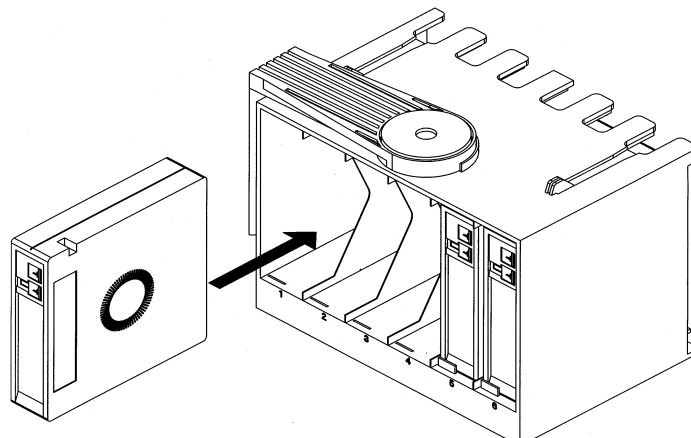

Operating the Autoloader

Loading/Unloading Tapes

CAUTION

Discharge static by touching the internal sheet-metal panel on the left side of the unit. Take care not to touch internal electronics.

NOTE

If the metal tab is already in the “Up” position, place the corner of the tape on the tab, and slide the tape into the slot. The latching mechanism will not click since the tab is already engaged. When tapes are “locked” into the magazine, the tapes will not fall out if the magazine is turned.

2. With the write-protect switch facing out of the Autoloader and at the top, load internal slots by pushing the tape in until it “clicks.”

NOTE

The magazine must be removed to load the internal slots (Figure 2-3).

Figure 2-3 Loading Internal Slots

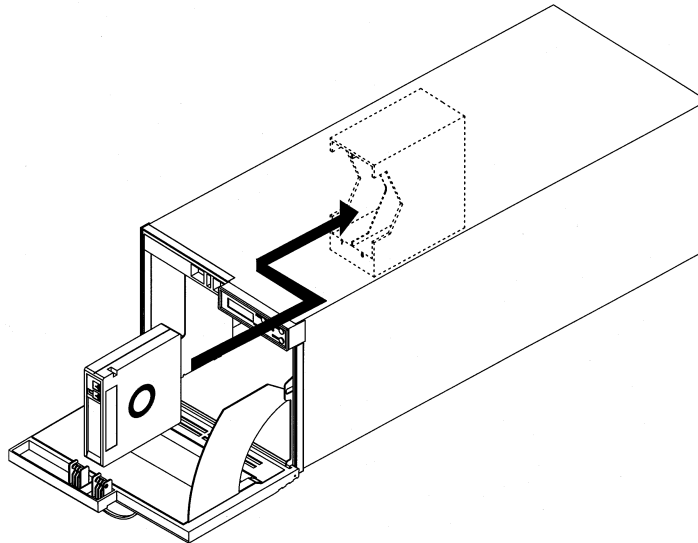

3. With the magazine handle facing out the front of the Autoloader, slide the magazine into the Autoloader until it “clicks” into place (Figure 2-1 on page 2-4).
4. Swing the magazine handle to the left to store.
5. Gently shut the front access door.

NOTE

The INVENTORY CHECK runs whenever the front access door closes so that an inventory of storage slot locations can be stored into memory. This process takes approximately thirty seconds. The inventory check will not run if the door is not completely shut.

Unloading Tapes

1. Remove the magazine by following the steps under “Opening the Door” on page 2-3 and “Removing the Magazine” on page 2-4.
2. Unload tapes from the magazine by pressing the tape in until it clicks and releases. Remove it after it partially ejects.

Autoloader Control Panel

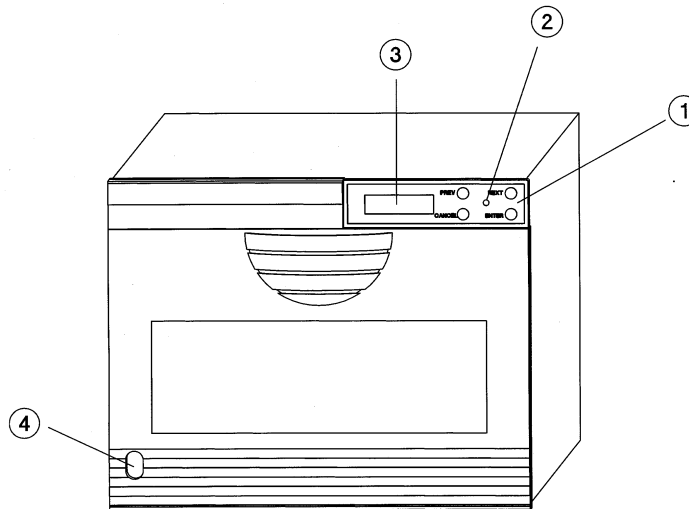

1	Control panel keys	<p>PREV: Scrolls the control panel choice backward by one.</p> <p>NEXT: Scrolls the control panel choice forward by one.</p> <p>ENTER: Selects the option currently being displayed.</p> <p>CANCEL: Cancels the current selection or steps you back to the previous menu.</p>
2	Activity light	<p>Steady green: Power is on.</p> <p>Flashing green: A tape is being accessed.</p> <p>Amber: An error occurred (see “Troubleshooting” on page 2-32).</p>
3	Two line, 16-character display	Displays the current operation or drive status. An asterisk (*) indicates a submenu for that task. Press ENTER on the control panel to access that menu.
4	Standby switch	Puts the unit’s power in standby mode. Turns off secondary circuits only.

Understanding Control Panel Messages

The control panel window is a two-line display with 16 characters per line that shows the status of the Autoloader or the current function.

Tape Status

The following example shows the display when the Autoloader is in the ready state.

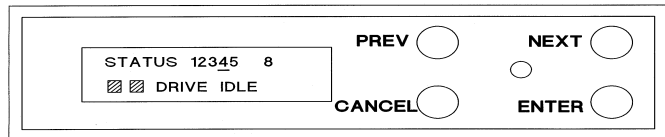

The numbers on the top line show that slots 1, 2, 3, 5, and 8 contain tapes, tape 4 is in the drive, and slots 6 and 7 are empty.

- A blinking number indicates that the tape is being moved from a slot or the drive.
- If a tape is in the drive, the number remains lit and is underlined (tape 4 in the figure above).
- If the Autoloader is empty, the top line reads `STATUS EMPTY`. On the bottom line, the display will read `LOADER READY` or a drive activity message and can include one of these indicators (represented by the shaded boxes above):

C is always displayed if the drive needs cleaning. If the drive is not active, `CLEAN DRIVE` will also display.

WP is displayed if a tape is write protected.

NOTE

In a menu option (other than a test menu), the Autoloader defaults to the drive status display when there has been no user interaction for three minutes.

Drive/Autoloader Status

The top display line normally shows the slot status or the current menu.

The bottom display line shows the drive/loader activity unless a control panel menu has been selected. See “Top-Level Menu Options” on page 2-12.

The status of the drive and Autoloader is indicated by the following:

- LOADER READY
- LOADER ACTIVE
- DRIVE IDLE
- CLEANING
- WRITING
- READING
- REWINDING
- SEEKING
- ERASING
- LOADING
- UNLOADING
- NO DRIVE (Displays if the drive isn't functioning properly)

Autoloader Display Menu Tree

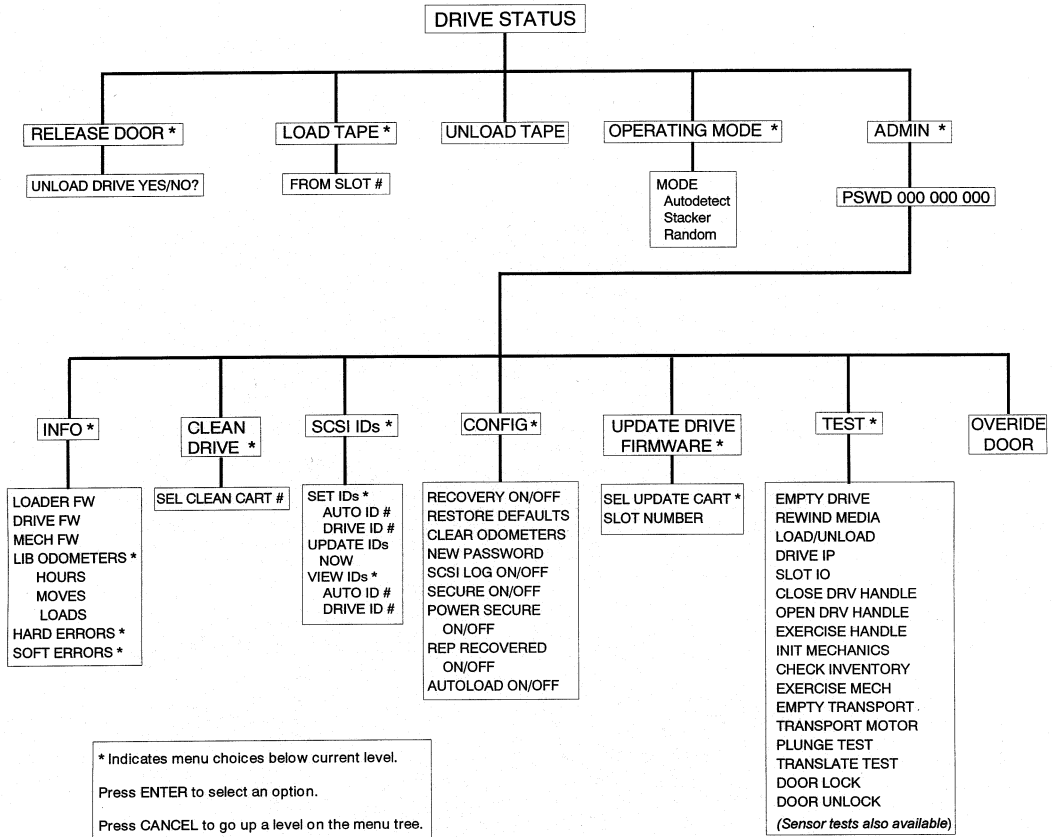

Top-Level Menu Options

NOTE

To move through the menus, use the control panel keys. If a menu selection is flashing, press **ENTER** to select that option. An asterisk (*) indicates sub-level menus.

The top-level menu contains the options listed in Table 2-1. Press **PREV** or **NEXT** when the Autoloader is not performing power-on self tests to view these menus:

Table 2-1 **Top-Level Menus**

Option	Function
RELEASE DOOR *	Unlocks the access door. See “Opening the Door” on page 2-3
LOAD TAPE *	Moves a tape from a slot to the drive. <ul style="list-style-type: none">• The second line displays FROM SLOT with the slot number.• Press NEXT until the desired slot number displays.• Press ENTER to select the slot number. The first full slot is the default slot. Only slots containing tapes can be selected.
UNLOAD TAPE *	Unloads a tape from the drive to the slot it came from.
ADMIN *	All functions under this menu option are password protected. See “Password-Protected Functions” on page 2-15.

Table 2-1 Top-Level Menus

Option	Function
OPERATING MODE * <i>(There are three operating modes.)</i>	<ul style="list-style-type: none"> • AUTODETECT MODE (default mode): Operates as if in Stacker mode until receiving a SCSI changer command. It then operates in Random mode until power cycled. <i>(See descriptions of Random and Stacker modes that follow.)</i> Changer commands are: INITIALIZE ELEMENT STATUS, READ ELEMENT STATUS, POSITION TO ELEMENT, MOVE MEDIA, and EXCHANGE MEDIA. After receiving one of these commands, the Autoloader operates as if in Random mode. • RANDOM MODE: Allows random access to tapes. <i>Mode:</i> In Random mode, the drive and the autoloader controller can be accessed via the SCSI bus. All stacker features are disabled after selecting Random mode. Tape cartridges can only be moved by using host SCSI commands to the Autoloader or by using the LOAD/UNLOAD front panel menu. <i>Operation:</i> The SCSI interface for the Autoloader in Random mode conforms to the SCSI-2 command specification for tape changer devices.

Table 2-1 **Top-Level Menus**

Option	Function
OPERATING MODE * (continued)	<ul style="list-style-type: none"> • STACKER MODE: Loads each tape sequentially after each drive unload request. <p><i>Mode:</i> When in Stacker mode, the autoloader controller will not use an ID and cannot be accessed from the SCSI bus. Only the drive ID is available. In this mode, the jumper cable may be removed from the back of the Autoloader, but it will not impact the system to leave it connected.</p> <p><i>Operation:</i> An autoload option and circular mode option is available under the CONFIG menu.</p> <p>If the autoload option is selected, the first available tape loads into an empty drive at power up. By default, autoload is off so that the user must use the front-panel LOAD command to load tape cartridges. When the host issues a SCSI unload command to the drive, the Autoloader automatically removes the tape cartridges from the drive and inserts the next available tape.</p> <p>If the circular mode option has been selected in CONFIG, the Autoloader will reload the first tape cartridge. If circular is disabled and the last tape cartridge has been unloaded, the Autoloader stops operating until the user loads more tape cartridges.</p> <p>While in Stacker Mode, if the Autoloader encounters a cleaning cartridge during the cycle, it will be loaded into the drive as normal, but will be automatically unloaded after the cleaning cycle. If the user indicates which slot contains the cleaning cartridge via the clean drive menu, the Autoloader will skip that slot.</p>

Password-Protected Functions

All ADMIN * functions are password protected.

1. Before accessing the following options, enter the password. (See page 2-17.)

A default password of 000-000-000 is set at the factory. Change this password when first using the Autoloader if it is in an unsecured location. (See page 2-18.) Ensure that you document this new password and keep it safe.

Table 2-2

Admin Menu Options

Option	Function
INFO *	Retrieves performance information stored in the Autoloader.
CLEAN DRIVE *	Allows the user to clean the drive.
SCSI IDs *	Displays or sets the SCSI addresses for the autoloader controller and drive.
CONFIG *	Customizes the autoloader functions. See “Configuring the Autoloader” on page 2-24.
UPDATE DRIVE FW *	Allows the user to update the firmware in the drive. See “Upgrading Firmware” on page 2-31.
TEST *	Runs internal autoloader tests. See “Running an Internal Test” on page 2-28.
OVERRIDE DOOR	Emergency door release that does not check the internal state of the Autoloader.

2. When a changeable menu selection is flashing, press **ENTER** to select the option, or press **PREV** or **NEXT** to display other available options.

Operating the Autoloader

Top-Level Menu Options

3. Press **ENTER** to select the flashing item.

The “Autoloader Display Menu Tree” on page 2-11 shows the autoloader menu options available throughout the control panel. To select the functions listed below the shaded boxes:

- a. Press **ENTER** when that option is displayed.
- b. Press **PREV** or **NEXT** to scroll through the list.
- c. To perform the displayed operation, press **ENTER**.

Entering the Administration Menu Password

A numeric password is required to access functions within the ADMIN * menu. A default password of 000-000-000 is set at the factory, which can be used when the Autoloader is powered on for the first time.

1. Starting at the top-level menu, press **NEXT** until ADMIN * is in the display window.
2. Press **ENTER**.
The default password displays, and the first set of zeros flashes.
3. Press **ENTER** to accept the first set of flashing zeros or **NEXT/PREV** to change the values.
4. Press **ENTER** to accept the second set of flashing zeros or **NEXT/PREV** to change the values.
5. Press **ENTER** to accept the last set of flashing zeros or **NEXT/PREV** to change the values.
INFO * displays.
6. Press **PREV** or **NEXT** until the desired function displays, then press **ENTER**.

Changing the Administration Menu Password

`ADMIN * / CONFIG * / NEW PASSWORD`

Change the password so that only authorized persons can access the Autoloader and change operation settings.

NOTE

Be sure you document a new password and keep it safe. If you forget the password, only a service representative can restore the default password.

1. Complete steps 1 through 6 in “Entering the Administration Menu Password” on page 2-17.
2. Press **NEXT** until `CONFIG *` displays, and press **ENTER**.
3. Press **NEXT** or **PREV** until `NEW PASSWORD` displays, and press **ENTER**.
`NEW 000 000 000` displays, and the first set of zeros flashes.
4. Press **NEXT** or **PREV** until the new number for the first part of the password displays, then press **ENTER** to select.
The second set of zeros flashes.
5. Press **NEXT** or **PREV** until the new number for the second part of the password displays, then press **ENTER** to select.
The last set of zeros flashes.
6. Press **NEXT** or **PREV** until the new number you wish to assign to the third part of the password displays, and press **ENTER** to select.
`PASSWORD CHANGED` displays, which indicates that the password has been saved to non-volatile RAM.
7. Press **CANCEL** three times to return to the ready state.

NOTE

After changing the password, you can save the new password to flash ROM by power cycling the Autoloader, which allows the password to be recovered if the Autoloader is powered off for more than ten days. If this step is not completed, the password changes may be lost.

Consult your system administrator before power cycling.

Setting or Viewing SCSI IDs

ADMIN * / SCSI IDs *

NOTE

If other peripherals are on the same SCSI bus, check to see which IDs are available.

When you choose SCSI IDs, you have two options:

- SET IDs * assigns a SCSI ID to the autoloader controller and a SCSI ID to the drive.
- VIEW IDs * displays the autoloader controller and drive settings.

Device	Default SCSI IDs
Autoloader ID	1
Drive ID	0

Setting SCSI IDs

ADMIN * / SCSI IDs * / SET IDs *

1. When SET IDs * is displayed, press **ENTER**.
 - AUTOLOADER ID #, DRIVE ID #, or UPDATE IDS NOW (use this last function after changing IDs to save) is displayed.
 - AUTOLOADER ID # stands for the current SCSI ID of the autoloader controller. DRIVE ID # is the current SCSI ID of the drive.
2. Press **NEXT** until the setting that you want to change is displayed, and then press **ENTER**. The current SCSI address flashes.
3. Press **NEXT** or **PREV** until the new SCSI address is displayed, and then press **ENTER**.

Operating the Autoloader

Setting or Viewing SCSI IDs

4. Press **NEXT** until UPDATE IDs NOW is displayed, and press **ENTER**.

One of the following messages is displayed:

- If the drive and controller are set to the same ID, CONFLICT-ABORTED displays, followed by SET IDs *.
- If the new settings are accepted, IDs SAVED then SCSI IDs * is displayed.
- If a drive serial communications error is detected while trying to set the SCSI IDs, DRV CONNECT ERR displays, followed by IDs NOT CHANGED. Any changes entered are lost, returning you to the SCSI IDs * menu.

5. Press **CANCEL** three times to return to the ready state.

NOTE

After changing an address, you may need to reboot the host for it to recognize the new SCSI IDs. Consult the system administrator and operating system documentation for the correct procedure for your system.

After changing the settings, you can save the new settings to flash ROM by power cycling the Autoloader, which allows the settings to be recovered if the Autoloader is powered off for more than ten days. If this step is not completed and the Autoloader is turned off for more than 10 days, the new settings may be lost.

Viewing SCSI IDs

```
ADMIN * / SCSI IDs * / VIEW IDs *
```

1. Enter the SCSI IDs * menu, which is under the ADMIN * menu.
2. Press **NEXT** until VIEW IDs * is displayed. Press **ENTER**.
3. AUTOLOADER ID # or DRIVE ID # is displayed. (AUTOLOADER ID # stands for the current SCSI ID of the autoloader controller, and DRIVE ID # is the current SCSI ID setting for the drive.)
4. Press **NEXT** or **PREV** to view the other ID.
5. Press **CANCEL** three times to return to the ready state.

Cleaning the Autoloader Tape Drive

`ADMIN * / CLEAN DRIVE *`

NOTE

Use a cleaning cartridge to clean the drive. The drive mechanism should only be cleaned if the clean drive status indicator displays (see “Understanding Control Panel Messages” on page 2-9). Excessive use of the cleaning cartridge can cause unnecessary wear on the drive head. The cleaning cartridge needs to be replaced after 20 cleaning cycles.

1. Starting at the top-level menu, press **NEXT** until `ADMIN *` appears in the control panel and then press **ENTER**.
2. Enter the password. `INFO *` displays.
3. Press **NEXT** until `CLEAN DRIVE *` is displayed, and press **ENTER**.
 - If the autoloader power has been turned off or the front access door has been opened since a cleaning cartridge location has been selected, `SET CLEAN CART *` is displayed. Press **ENTER** and select a slot location.
 - If the autoloader power has not been turned off or the front access door has not been opened since a cleaning cartridge location has been selected, `CLN CART LOC #` displays. (The number that flashes indicates the storage location of the cleaning cartridge.) If the storage slot location is correct, press **ENTER** and go to step 4. To select a different slot location, press **NEXT** or **PREV** until the correct slot location is displayed, press **ENTER**, and go to step 4.

Operating the Autoloader

Cleaning the Autoloader Tape Drive

4. If a tape is in the drive, a message will display to indicate that the drive must be emptied before cleaning.
 - If the slot location chosen in step 3 did not contain a cleaning cartridge, NOT CLEAN CART displays briefly and then CLEAN FAIL # displays. Press **CANCEL** twice to return to the ready state. Locate the cleaning cartridge. If no cleaning cartridge is present, insert one into an available slot.
 - In the event of a drive error, FAILED displays and then the CLEAN DRIVE menu appears.
5. Press **CANCEL** two times to return to the ready state.

Drive Cleaning Errors

Table 2-3 describes situations that can cause drive cleaning errors. The message CLEAN DRIVE is displayed when a tape cartridge may be at fault.

For drive cleaning instructions, refer to “Cleaning the Autoloader Tape Drive” on page 2-21.

NOTE If the drive cleaning problems persists, call an authorized service provider.

Table 2-3 Drive Cleaning Troubleshooting

If this happens . . .	The reason is . . .	So you need to . . .
A brand new tape is used and a drive cleaning message is received.	Debris from the tape manufacturing process was deposited on the drive head.	<ul style="list-style-type: none"> • Clean the drive using the tape drive cleaning procedure in “Cleaning the Autoloader Tape Drive” on page 2-21. • If the message is displayed again within a short amount of time, replace the tape.
An older, frequently-used tape is loaded and a drive cleaning message is received.	Dust from frequent tape loads and unloads has probably built up on the tape cartridge and deposited on the drive head.	<ul style="list-style-type: none"> • Clean the outside of the tape cartridge using a damp cloth. • Clean the tape drive using the tape drive cleaning procedure found in “Cleaning the Autoloader Tape Drive” on page 2-21.
An older, frequently-used tape causes a cleaning message to be displayed for the second time.	The cleaning cartridge needs to be replaced or the tape is probably damaged. (Damaged tapes can result in unnecessary use of the cleaning cartridge.)	<ul style="list-style-type: none"> • Verify the tape is readable by clearing the error message. • Try reading the tape again. • If the tape can be read, back up data from the damaged tape to another tape cartridge, and discard the damaged one. • Replace the cleaning cartridge.

Configuring the Autoloader

ADMIN * / CONFIG *

1. In the CONFIG * menu, press **NEXT** or **PREV** until the desired operation is displayed, then press **ENTER**.
If the option has multiple settings, the current setting flashes. Press **NEXT** or **PREV** until the desired setting is displayed.
2. Press **NEXT** or **PREV** to change the setting.
3. Press **ENTER** to select the setting. OPTION SAVED is displayed.
4. Press **CANCEL** two times to return to the ready state.

Table 2-4

Configuration Options

Config Name	Description	Default
RECOVERY ON/OFF	If set to ON, the Autoloader attempts to recover from errors. If set to OFF the Autoloader stops moving if an error occurs. Recovery should remain ON under normal conditions.	ON
RESTORE DEFAULTS	Sets all autoloader configuration options to their default settings.	—
CLEAR ODOMETERS	Used by service personnel only. Sets all autoloader odometers to zero.	—
NEW PASSWORD	Allows the password to be changed.	—
SCSI LOG ON/OFF	Used by service personnel only. Tracks internal SCSI states and saves the information to a log.	OFF
SECURE ON/OFF	When set to ON, the RELEASE DOOR option will not unlock the door. When set to OFF, the door can be released.	OFF

Table 2-4 Configuration Options

Config Name	Description	Default
POWER SECURE ON/OFF	When set to ON, the SECURE ON/OFF setting is retained in the event of a power outage. When set to OFF, the Autoloader returns to its default setting of SECURE OFF when power is restored.	OFF
REP RECOVERED ON/OFF	When set to ON, recovered errors are reported; when set to OFF, the recovered errors are not reported.	ON
AUTOLOAD ON/OFF	When set to OFF in the Stacker mode, a tape must be loaded into the drive using the front panel. When set to ON, the first available tape is loaded when the unit is powered on and the drive is empty. This option is only used when the operation mode is set to Stacker mode.	OFF
COMPRESSION ON/OFF	Displays the current setting of drive compression. When set to ON, the drive will compress data unless the host turns it off. When set to OFF, the drive will not compress data, unless requested by the host. <i>Note:</i> When the drive is empty, the display will always read that compression is OFF.	ON
CIRCULAR ON/OFF	When set to ON, the first tape is reloaded after the last tape unloads. This option only functions in Stacker or Autodetect mode. <i>Caution:</i> Data overwrite can occur since the loader will reload the first tape after unloading the last tape.	OFF

Table 2-4 **Configuration Options**

Config Name	Description	Default
INQ TOGGLE	<p>When set to ON, the inquiry string for the product family is reported to the SCSI bus. When set to OFF, the inquiry string for this autoloader model is reported to the SCSI bus.</p> <p><i>Note:</i> In most cases, the product family and model inquiry strings will be the same.</p>	OFF

Retrieving Autoloader Information

```
ADMIN * / INFO *
```

Information logs describing the autoloader operation are displayed in the INFO * menu. The information logs are described in Table 2-5.

1. When INFO * displays, press **ENTER**.
2. Press **NEXT** until the desired log name displays and then press **ENTER**.
3. Press **CANCEL** two times to return to the ready state.

Table 2-5

Information Logs

Log Name	Description
LOADER FW #	Displays the autoloader's firmware revision number.
DRIVE FW #	Displays the drive's firmware revision number. The drive firmware number will look similar to this: DRV FW (183C) 60 where 18 is the build code, 3C is the hex value, and 60 is the decimal value.
MECH FW #	Displays the internal mechanism's firmware revision number.
LIB ODOMETERS *	Press ENTER to select the odometer logs for power-on hours, moves, and drive loads.
HARD ERRORS * (see "Understanding Error Messages" on page 2-40)	Displays a log of commands with unrecoverable errors. Returns either NO HARD ENTRIES or ENTRY #. Press ENTER to view the log for the currently displayed error. Press NEXT to view the next error.
SOFT ERRORS * (see "Understanding Error Messages" on page 2-40)	Displays a log of commands with recovered errors. After an error, returns either NO SOFT ENTRIES or ENTRY #. Press ENTER to view the log for the currently displayed error. Press NEXT to select the next error.

Running an Internal Test

ADMIN * / TEST *

1. When TEST * is displayed, press **ENTER**.
2. Press **NEXT** until the desired test is displayed, and press **ENTER**.
NUM LOOPS 1 is displayed, where the 1 is flashing.
3. Press **NEXT** until the number of desired test loops displays (1, 10, 100, 1000, or forever) then press **ENTER** to select.

NOTE

Press **CANCEL** at any time to abort a test. The last test cycle will complete before cancelling. TEST CANCEL - WAIT is displayed while the last test cycle completes.

Descriptions of the internal tests available from the control panel are in Table 2-6.

Table 2-6 Tests Available from the Control Panel

Test Name	Description
EMPTY DRIVE	<i>Do not run this test if the drive contains a tape cartridge with data.</i> Moves a tape out of the drive mechanism and returns it to its home storage slot if the location is known, otherwise the tape is placed into the first available storage slot.
REWIND MEDIA	<i>Do not run this test if the Autoloader contains a tape cartridge with data.</i> Rewinds the tape in the drive and opens the solenoid in the drive handle. Use the OPEN DRV HANDLE test to open the drive and remove the tape.
LOAD/UNLOAD	Selects a random full slot and moves the tape to the drive. After the tape loads, the transport moves to another slot and then returns to the drive, unloading the tape to its original location.

Table 2-6 Tests Available from the Control Panel

Test Name	Description
DRIVE IO	Moves a tape from the drive to the transport or from the storage slot to the transport. This tape is then moved from the transport to the drive and then back to the transport the selected number of test loops. When complete, the tape is returned to the original location.
SLOT IO	Moves a tape from a random full slot to the transport. The tape is then moved back to its original location.
CLOSE DRV HANDLE	Closes the drive handle. Only one operation is performed, regardless of the loop count chosen.
OPEN DRV HANDLE	Use this test after performing the REWIND MEDIA test to manually remove tapes. Opens the drive handle. Only one operation is performed, regardless of the loop count chosen.
EXERCISE HANDLE	Closes then opens the drive handle.
INIT MECHANICS	Performs the power on self-test. Each test is run one time per test loop.
CHECK INVENTORY	Functions the same as the SCSI Initialize Element Status command. This test physically scans the entire unit to determine which storage slots contain tape cartridges and if the drive contains a tape. <i>Note:</i> This test will appear as INVENTORY TST in all control panel error messages.
EXERCISE MECH	Runs the TRANSLATE TEST, IO MAGAZINE, and IO DRIVE tests. Each test is run one time per test loop.
EMPTY TRANSPORT	Moves the media in the transport back to the original slot. The test passes if the transport is empty.

Autoloader Operation

Operating the Autoloader
Running an Internal Test

Table 2-6 Tests Available from the Control Panel

Test Name	Description
TRANSPORT MOTOR	Runs the motor in the transport back and forth.
PLUNGE TEST	Runs the tape pusher back and forth.
TRANSLATE TEST	Translates from side to side. No tape cartridge is required.
DOOR LOCK	Locks the door.
DOOR UNLOCK	Unlocks the door.
EXERCISE LOCK	Locks then unlocks the door.
DOOR SENSOR	Displays if the door is open or not.
PUSH SENSOR 1	Displays the value of transport sensor 1.
PUSH SENSOR 2	Displays the value of transport sensor 2.
DOOR LOCK SENSOR	Displays the current value of the door lock sensor.
DRV HNDL OPEN SENSOR	Displays the current value of the drive handle open sensor.
DRV HNDLE CLOSE SENSOR	Displays the current value of the drive handle close sensor.
T MAG SENSOR	Displays the current value of the magazine side transport sensor.
T DRIVE SENSOR	Displays the current value of the drive side transport sensor.
MAG PRESENT SENSOR	Displays the current value of the magazine present sensor.
CaPUSH SENSOR	Displays the current value of the cartridge push sensor.
DRIVE SENSOR	Displays the current value of the drive side transport position sensor.

Upgrading Firmware

Upgrading Drive Firmware from Tape

1. Call your service representative to get the drive upgrade tape.
2. Ensure that the drive is empty.

If a tape is in the drive, use the front panel display to return the tape to a storage slot. See “Loading/Unloading Tapes” on page 2-3.

3. Load the drive upgrade tape into the Autoloader. See “Loading/Unloading Tapes” on page 2-3. Make a note of the slot in which you place the drive upgrade tape.
4. From the Admin * menu, select Update Drive FW. Press **Enter**.
5. Select the slot number that contains the firmware upgrade tape. Press **Enter**.
6. Watch the upgrade status on the control panel.

NOTE

Error messages will only display for a few seconds after a failure. Always check the firmware level from the INFO * menu after an update to ensure the update was successful.

Troubleshooting

Before calling for service, locate the serial and model numbers for your Autoloader. The serial and models numbers are located inside the Autoloader under the magazine.

For problems that may be related to the host or application software, refer to the host system documentation or to the application software instructions.

CAUTION

Do not cycle power while the device is active on the SCSI bus. Cycling power when the SCSI bus is active can cause data loss and/or problems with the SCSI interface.

Table 2-7**Troubleshooting Table**

Problem	What to do
Autoloader will not power on or no display messages appear.	<ul style="list-style-type: none">• Check the power cord connections.• Make sure the standby switch is on.• Make sure there is power to the outlet.• Replace the power cord with a known good one.• If the Autoloader still won't power on, call a service representative.
Power on self-test failed. DEVICE FAILED is displayed in the control panel with an error code on the next line.	<ul style="list-style-type: none">• Remove all tapes and the magazine, then cycle power. If self-test passes, reload tapes and magazine.• If the power-on test fails again, note the error code, and call a service representative.

Table 2-7 Troubleshooting Table

Problem	What to do
<p>Host unable to communicate.</p>	<ul style="list-style-type: none"> • Verify that SCSI bus adapter and terminator types match (HVDS, LVDS, or Single-Ended). • Check cable and terminator for correct connections to the host and Autoloader. • Check for bent or broken pins on cables and terminators. • Replace cable and terminator with known good components. • Check to see if operating mode is set to stacker (see “Top-Level Menu Options” on page 2-12). <p><i>Caution:</i> Unit may not meet EMI regulatory specifications if proper cable is not used.</p>
<p>The Autoloader’s power failed while a tape was in the drive and did not return to the ready state after the power came on.</p>	<ul style="list-style-type: none"> • Press the standby switch off and then on again to run the power-on inventory test. • If the power-on test is unsuccessful, switch off the power and call a service representative for assistance.

Autoloader Operation

Table 2-7 Troubleshooting Table

Problem	What to do
<p>An error message appears during or after inserting the magazine or loading tapes.</p>	<ul style="list-style-type: none"> • Verify that tapes are inserted correctly in the magazine. (See “Loading/Unloading Tapes” on page 2-3.) • Verify that the correct tape type is used (Type IIIXT or IV). • If the activity light on the control panel is amber, power cycle the Autoloader. Try to load the magazine again when the drive and status indicators display. • If SECURITY ENABLED is displayed, a security option has been set that prevents tapes from being loaded into or removed from the Autoloader. • If a FAILED message still is displayed, call a service representative.
<p>Error Code Hex 62, OVERFULL is displayed.</p>	<ul style="list-style-type: none"> • Remove tapes from internal storage slots. • Power cycle the unit. • Call service if unsuccessful.
<p>Changed drive SCSI ID but the new ID is not recognized.</p>	<ul style="list-style-type: none"> • Use the VIEW ID option to verify that the new ID was saved after selecting UPDATE IDs. • Power cycle, or reboot the host.
<p>Cannot remember the administration menu password.</p>	<ul style="list-style-type: none"> • Try the default password (000-000-000). If the default is not accepted, call a service representative.

Table 2-7 Troubleshooting Table

Problem	What to do
<p>Attempted to open the front access door, but a RESERVED message is displayed.</p>	<ul style="list-style-type: none"> • The host or application software may have reserved an element (slot or drive) and must unreserve it. Refer to the system documentation to unreserve a tape. • If unable to unreserve the element, go to the SET DEFAULTS option under CONFIG * to clear the reservation. • A security configuration was set to prevent tape removal. See SECURE ON/OFF in the list of configuration options found in “Configuring the Autoloader” on page 2-24.
<p>Started a test and need to stop.</p>	<ul style="list-style-type: none"> • Press CANCEL. The current test loop continues until finished, then the test stops.
<p>DO INVENTORY TST is displayed.</p>	<ul style="list-style-type: none"> • Using the standby switch, power cycle the Autoloader, or run CHECK INVENTORY under the TEST * menu.
<p>Cannot write to the tape.</p>	<ul style="list-style-type: none"> • Check the host file system access permissions. • Verify that you are using the correct tape type (Type IIIXT or IV). • Check the write-protect tab on the tape to assure write-enabled status. See “Write-Protecting Tape Cartridges” on page 3-5. • Check the application software documentation. • Check termination on cabling.

Table 2-7 **Troubleshooting Table**

Problem	What to do
Cannot read the tape.	<ul style="list-style-type: none">• Check the host file system access permissions.• Verify that you are using the correct tape type (Type IIIXT or IV).• Check the application software documentation.• Clean the drive and try reading the tape again.• Check termination on cabling.
Tape stuck in transport.	<ul style="list-style-type: none">• Run the EMPTY TRANSPORT TEST under the TEST * menu.• If unsuccessful, power off. Caution: Power down the unit by unplugging the power cord.• Open the door, remove the magazine.• Gently pull the tape out of the transport. If you can not remove it, rotate the upper aluminum shaft to eject the tape. Examine tape case for damage and discard if found.• Replace magazine.• Power on unit.• Call service if problem occurs again or if the tape cannot be removed from the transport.

Table 2-7 Troubleshooting Table

Problem	What to do
Tape stuck in magazine slot.	<ul style="list-style-type: none"> • Power off the Autoloader by unplugging the power cord from the back of the unit. • Remove the magazine, and check for and remove any obstruction. • Gently remove the tape by pushing on the tape to release it. • Push down on the silver tab in front of the stuck tape to pull the tape out. • Call service if unsuccessful.
Tape stuck in internal storage slot.	<ul style="list-style-type: none"> • Power off the Autoloader. <i>Caution:</i> Power off the Autoloader by unplugging the power cord. • Remove the magazine. • Gently remove the tape. • Push down on the silver tab underneath the stuck tape to pull the tape out. • Call service if unsuccessful. <p><i>Note:</i> Tapes can become stuck in internal storage slots because of tape cartridge wear. If the tape cartridge shows signs of wear, recover data and replace the tape.</p>
When loading tapes, a tape does not “click” into place.	<ul style="list-style-type: none"> • Remove the magazine from the autoloader and try reloading the tape.

Table 2-7 Troubleshooting Table

Problem	What to do
Tape stuck in drive.	<ul style="list-style-type: none"> • Run the TRANSLATE TEST to move the transport out of the way. • Run the REWIND MEDIA test to rewind the tape. If you are unable to rewind the tape, call service. • Use the OPEN DRV HANDLE internal test to release the tape. • Run the UNLOCK DOOR test to release the front door • If problems persist, call service representative. <p><i>Caution:</i> Do not use the RELEASE DOOR option because this will cause the transport to move in front of the drive and can cause further damage.</p>
Slot blocked (magazine or internal slot).	<ul style="list-style-type: none"> • Open door, and remove magazine. • Check for and remove any obstruction. Cycle power. • Call service if unsuccessful.
Magazine will not go in.	<ul style="list-style-type: none"> • Verify that the magazine is inserted correctly. See “Removing the Magazine” on page 2-4. • Open door. Check for and remove obstruction. • Check for damage or wear to the magazine rails (bottom and top of Autoloader), magazine slots, and outside of magazine. Replace the magazine if necessary. • Call service if unsuccessful.

Table 2-7 Troubleshooting Table

Problem	What to do
Magazine will not come out.	<ul style="list-style-type: none"> • Open door. Check for and remove obstruction. • Call service if unsuccessful.
Transport is misaligned. Transport won't pick. Tape/drive/transport is misaligned.	<ul style="list-style-type: none"> • Call a service representative.
Recurrent cleaning light on.	<ul style="list-style-type: none"> • Replace existing tape with a new tape. See "Drive Cleaning Errors" on page 2-23. • Replace cleaning cartridge. • Call service if unsuccessful.
Transport won't access the two permanent storage slots.	<ul style="list-style-type: none"> • Open door. Check for and remove any obstruction. • Call service if unsuccessful.
Could not find all slot positions in a SCAN MAGAZINE command.	<ul style="list-style-type: none"> • Verify that all small holes at the bottom inside edge of the magazine are clean. • Verify that the magazine is correctly inserted. See "Removing the Magazine" on page 2-4.

Understanding Error Messages

When receiving an error code, the front panel will alternate between displaying the error code and the text string, which will look similar to the following:

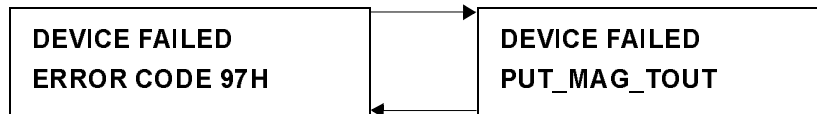

NOTE

All error codes (like 97H in the example above) can be decoded by pressing **ENTER**.

To understand the error code:

1. Press **ENTER** to view the error log entry.
2. Press **NEXT** to get the following information:
 - Field Replaceable Units (FRUs)
 - Motion Type
 - Source
 - Destination 1
 - Destination 2
 - Odometer
 - Error Listing (last 5 transport errors)
 - Error Count (Number of errors on this move)

NOTE

The same error code information is available in the error logs, which you can access through this menu path:

ADMIN * / INFO * / HARD ERRORS *

Table 2-8 Common Error Codes

Error	What it means	Recovery
00H	Drive command timeout.	Power cycle.
2DH	Door is open.	Ensure the door is closed and power cycle.
33H	Invalid configuration to run an internal test. Attempting to run a front-panel test without tapes in the correct place.	Ensure the tapes are in the storage slots and no tapes are in the transport or drive.
34H	Need to run INVENTORY CHECK test.	Run the INVENTORY CHECK test and power cycle.
35H	Internal test failed for an unknown reason.	No action necessary.
63H	Loader command timeout.	Power cycle.
84H	Tape is in transport during powerup.	Ensure the transport is empty and power cycle.
85H	Unable to initialize transport.	Verify the magazine and tapes are correctly installed, and power cycle.
87H	Time out moving a tape onto or off of the transport during mechanical initialization.	Ensure the tapes move in and out of the storage slots and reinstall them. Power cycle when complete.

Operating the Autoloader
Understanding Error Messages

Table 2-8 Common Error Codes

Error	What it means	Recovery
88H	Time out finding the transport home position during mechanical initialization.	Ensure that tapes are not blocking transport motion and power cycle.
94H	Time out moving tape from the drive onto the transport. If this error occurs, the loader controller will try to move the tape back into the drive.	Power cycle and retry the command.
95H	Time out moving to a slot.	Verify that the transport is not obstructed and power cycle.
97H	Time out unloading tape into the slot during a tape unload. This error can also occur during an extended scan magazine (a tape that was in the magazine is now on the transport).	<p>If failure occurred when moving a tape to the magazine, ensure the silver tab is in the “Up” position. If not, load tape backwards and remove to leave the tab “Up.”</p> <p>If error occurs in internal slot, ensure silver tab is not in the “Up” position. Load tape backwards to retract the tab.</p>
9BH	Could not unlock the door during an unlock door command.	Unplug and then plug back in.
9CH	Did not find all of the valid slot positions during a SCAN MAGAZINE command.	Remove the magazine and check for obstructions along the small inside rail holes. Reinstall magazine.

Table 2-8 Common Error Codes

Error	What it means	Recovery
9FH	Could not lock the door during a door lock command or during a scan command if the door is unlocked.	Unplug and plug back in.
A4H	Time out moving a tape from a slot onto the transport.	Ensure the tapes move in and out of the storage slots and reinstall them. Power cycle when complete.
A8H	Time out moving a tape from the transport into the drive during a load tape command.	Drive has probably failed. Call service
ACH	Time out closing the drive handle.	If the drive is empty, run the EXERCISE HANDLE test 10 loops. Power cycle. Call service if the error occurs again. If a tape is in the drive, power cycle and unload tape via the UNLOAD TAPES front panel menu. Once tape is removed, run EXERCISE HANDLE test.
B2H	Door open without getting a command.	Ensure the door is closed and power cycle.
B5H	Missed a slot during transport movement.	Power cycle and retry command.

Table 2-8

Common Error Codes

Error	What it means	Recovery
B8H	Unable to open the drive handle.	If the drive is empty, run the EXERCISE HANDLE test 10 loops. Power cycle. Call service if the error occurs again. If a tape is in the drive, power cycle and unload tape via the UNLOAD TAPES front panel menu. Once tape is removed, run EXERCISE HANDLE test.

3 Using and Maintaining Tapes

Chapter Overview

DLTtape™ cartridges are an integral part of the storage process. This chapter explains how to:

- Label tape cartridges
- Label the magazine
- Write-protect a tape cartridge
- Maintain tape cartridges
- Inspect tape cartridges for damage

Labeling Tape Cartridges

The backup application software may need to keep track of the following information:

- Date of format or initialization
- Tape owner (group/department, etc.)
- Storage purpose (backup, old version of operating system, etc.)

NOTE

If the host software doesn't keep track of this information, create a method of doing so.

Slide the label into the slot on the face of the tape as illustrated in Figure 3-1.

Figure 3-1 **Label Position**

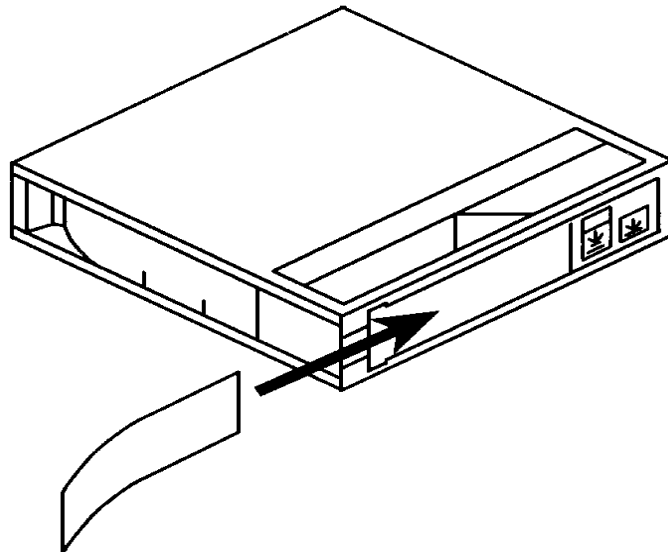

Labeling the Magazine

Pop out the clear label holder on the magazine by pushing the holder in and sliding it out.

1. Remove the blank label that is supplied with the magazine from the label holder.
2. Mark the label with information that describes the contents.
3. Insert the label into the label slot on the base of the magazine.
4. Place the clear label holder over the label to secure it, shown in Figure 3-2.

Figure 3-2 Magazine Label Position

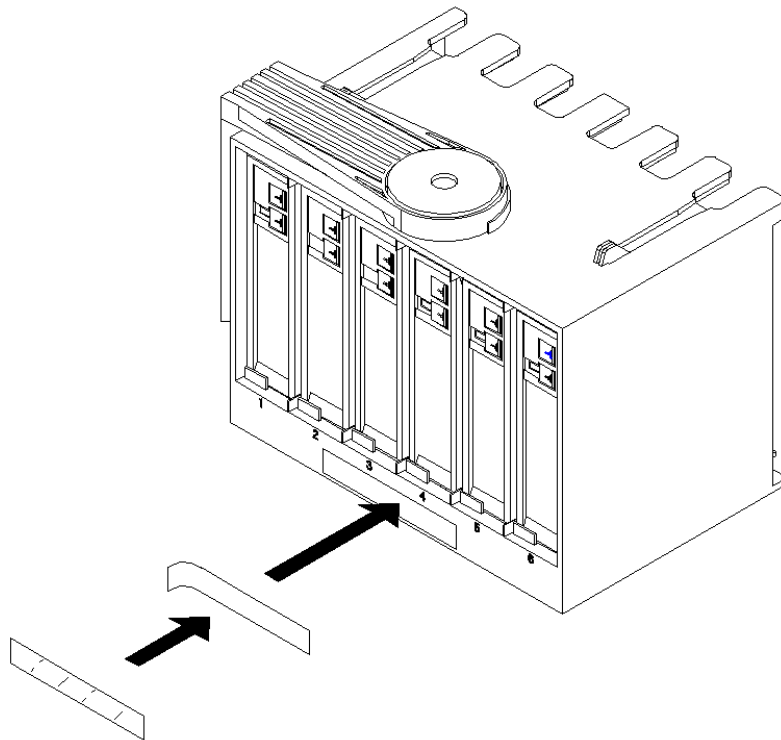

Write-Protecting Tape Cartridges

The write-protect switch prevents writing additional data to the tape. To change the write-protect setting, move the write-protect switch to:

- Position A in Figure 3-3 to prevent writing data to the tape. The orange indicator on the tape can be seen when the write-protect switch is ON.
- Position B in Figure 3-3 to allow data to be written to the tape. The orange indicator on the tape cannot be seen when the write-protect switch is in the OFF position.

Data can be read from the tape when the write-protect switch is in either position.

Figure 3-3 Write-Protect Button Settings

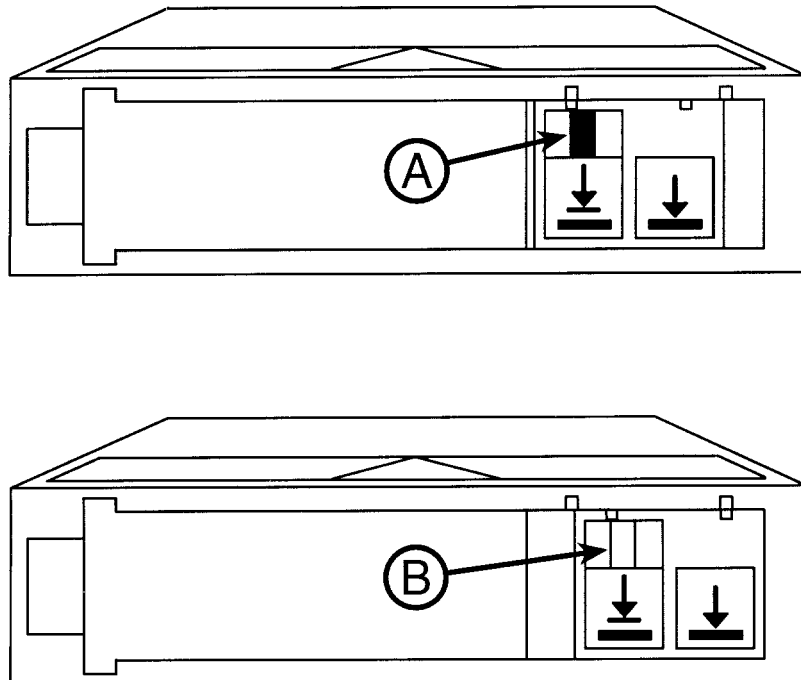

Maintaining Tape Cartridges

Follow these guidelines to maintain tape cartridges:

Do Not:

- Expose the tape to magnetic fields.
- Leave the tape in the tape drive when the power is off.
- Expose the tape to extreme temperatures or humidity. Acceptable storage temperatures range from 16–32° C (60–90° F). Acceptable operating or storage humidity ranges from 20%–80%.
- Expose the tape to moisture or direct sunlight.
- Drop the tapes or subject tapes to any physical shock. (See “Inspecting Tape Cartridges” on page 3-7.)
- Open the tape lid, exposing the tape to possible contamination or physical damage.
- Touch the tape surface.
- Take the tape apart.
- Use graphite pencils, water soluble felt pens, or other debris-producing writing instruments to label tapes.
- Erase a label. Replace it.

Do:

- Remove the dust on the outside of the tape with a damp cloth.
- Store tape on edge, not flat.
- Store tapes in their plastic containers and in environmental conditions of 18–28° C (64–82° F) and 40%–60% relative humidity.

Inspecting Tape Cartridges

Tape cartridges need to be inspected if they have been dropped or if they are associated with a drive that has a detached leader. If defective media is loaded into the Autoloader, it in turn causes the drive to lose its leader, potentially requiring drive replacement. (Refer to Figure 3-4 for the correct position of the leader.)

To check the leader position, the door lock needs to be lifted to release the cartridge door. Use your index finger to release the door lock.

- Inspect the cartridge for a broken, unseated, or misaligned cartridge leader.
- Verify that the leader has no cuts or damage.
- Verify that the leader is inside the reel guides.
- Shake the cartridge gently to verify that no internal parts are rattling. If the cartridge rattles, it can no longer be used and must be replaced.

CAUTION

If the leader is in any other position than that shown in Figure 3-4, the cartridge is not longer usable.

Figure 3-4 Leader Buckling Loop

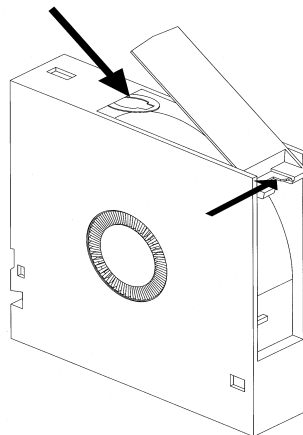

DO NOT Use Cartridges:

- That have been dropped.
- With mislocated leaders.
- With cut or damaged leaders.
- With an audible rattle when shaken.
- With tape or leaders which have been touched with bare fingers (may transfer oils to the tape head).
- With adhesives used on the top, sides, or bottom of the cartridge. Use the label slot only.

NOTE

Taking a few moments to check the condition of tape cartridges and verifying that their leaders are not damaged will save repeated failures and help ensure uninterrupted back-up.

A Support and Customer Service

Supplies and Accessories

A full range of supplies may be ordered through a Hewlett-Packard authorized dealer, sales office, or through HP Customer Care. To contact HP Customer Care, call 1-800-227-8164.

Call 1-800-752-0900 for the location of the nearest authorized Hewlett-Packard dealer.

NOTE

See “Product Components” on page 1-3 for a list of supplies and accessories for the Autoloader.

Hewlett-Packard Customer Support

If a DLT Autoloader fails during the warranty period, and the troubleshooting guide and user manual does not solve the problem, you can receive support by doing the following:

- Access HP Support on the World Wide Web at:
www.hp.com/support/automated
- Consult HP FIRST (FAX Information Retrieval Support Technology) facsimile assistance services, see phone numbers below).
- Contact your authorized HP dealer or Authorized Service Provider.
- Call the HP Customer Care Center in your region (“Telephone Support During Warranty” on page A-5).

If you purchased a service contract through HP or an authorized reseller, make sure that you register immediately. Failure to register may result in slower response time. Registering allows the local repair office to prepare for the proper response level needed. If your DLT Autoloader fails while under the support contract period, contact the appropriate support number included in your contract information.

If the DLT Autoloader fails after the warranty period, contact your authorized HP dealer/distributor or the nearest HP sales and service office. Customers in the US and Europe can also use a credit card for phone assistance. For details, see “Telephone Support After Warranty” on page A-8.

Information Needed for Support

Before calling, please have the following information ready:

- Model number of your library
- Serial number
- Brand and model of your host computer
- Brand and model of your SCSI or fibre channel host adapter
- Library drivers and backup application software that you are using and the version number(s)

Faxback Services

HP First is an automated system that faxes requested product information and/or technical support documents to you. These Faxback services are available 24 hours a day, 7 days a week. Simply dial the fax number from a touch-tone telephone or Group 3 facsimile machine, and follow the voice prompts that guide you to select an index of available support and product documents.

North and South America and Canada 800-333-1917

Hewlett-Packard Web Site

Support and Product Information: <http://www.hp.com/go/automated>

Telephone Support During Warranty

To obtain technical assistance, call the support representative nearest you.

North and South America

Argentina	(541) 778 8380
Brazil	(011) 829 6612
Canada	905-206-4663
Chile	800 360 999
Mexico	800 427 6684
United States	(970) 635-1500; Monday - Friday, 7 am - 5pm Mountain Time
Venezuela	800 47 888 (Caracas 207 8488)

European Customer Support Centers

Monday - Friday, 8:30 - 18:00 (C.E.T)

NOTE

Language or country support might not be available for all products.

Austria	+ 43 (0) 7114 201080
Belgium, Dutch	+ 32 (0) 2 626 8806
Belgium, French	+ 32 (0) 2 626 8807
Denmark	+ 45 39 29 4099
English International	+ 44 (0) 171 512 52 02
Finland	+ 358 (0) 203 47 288
France	+ 33 (0) 1 43 62 34 34
Germany	+49 (0) 180 52 58 143
Ireland	+ 353 (0) 1 662 5525
Israel	+ 972 (0) 9 9524848
Italy	+ 39 02 264 10350
Netherlands	+ 31 (0) 20 606 8751

Support and Customer Service
Hewlett-Packard Customer Support

Norway	+ 47 22 11 6299
Poland	+ 48 22 519 06 00
Portugal	+ 351 (0)1 318 00 65
Russian Federation	+ 7 095 916 98 21
South Africa	+ 27 (0) 11 8061030
Spain	+ 34 902 321 123
Sweden	+ 46 (0) 8 619 2170
Switzerland	+ 41 (0) 848 80 11 11
Turkey	+ 90 212 224 59 25
United Kingdom	+ 44 (0) 171 512 52 02

Asia Pacific Customer Support Centers

Australia	+ 61 3 8877 8000
China	+ 86 (0) 10 6564 5959
Hong Kong	800 96 7729
India	+ 91 11 682 6035
Indonesia	+ 62 21 350 3408
Japan	+ 81 3 3335 8333
Korea	+ 82 2 3270 0700
Outside Seoul	080 999 0700
Malaysia	+ 60 3 295 2566
New Zealand	+ 64 9 356 6640
Penang	1 300 88 00 28
Philippines	+ 63 2 867 3551
Singapore	+ 65 272 5300
Taiwan	+ 886 2 717 0055
Thailand	+ 66 2 661 4000
Vietnam	+ 84 (0) 8 823 4530

Elsewhere

Contact your authorized HP dealer/distributor or the nearest HP sales and service office.

Telephone Support After Warranty

US and Canada

Using a VISA or MasterCard, call one of the following:

- (800) 810-0130: Per incident fee of \$25.00 will be charged to the credit card.
- (900) 555-1800: \$2.50 per minute with a maximum of \$25.00 will be charged to the credit card.

Europe

Call the appropriate number listed under “European Customer Support Centers” on page A-5. A per incident fee will be charged for after-warranty support. Please have a credit card, PO number, or billing number address ready.

Elsewhere

Contact your authorized HP dealer/distributor or the nearest HP sales and service office for after-warranty support.

HP Reseller Locator Numbers

US (800) 752-0900

Canada (800) 387-3867

Mexico and South America (305) 267-4220

B **Safety and Regulatory**

Chapter Overview

This section contains important safety and regulatory information for the United States, Finland, Sweden, Germany, United Kingdom, European Union, Japan, and Taiwan.

Regulatory Information

Declaration of Conformity

according to ISO/IEC Guide 22 and EN 45014

Manufacturer's Name: Hewlett-Packard Co.

Manufacturer's Address: Storage Systems Division
700 71st Avenue
Greeley, CO 80634 USA

declares, that the product

Product Name: DLT Tape Library

Model Numbers: C6280J, C6280L, C6280F, C6280H, C6282J, C6282L, C6282NB, C6282PB, C6282RA, C6282SA, A5501A, A1375A

Product Options: All Options

conforms to the following Product Specifications:

Safety: EN 60950:1992 +A1 +A2 +A3 +A4 +A11 / IEC 60950:1991 +A1 +A2 +A3 +A4
EN 60825-1:1994 +A11:1996 / IEC 60825-1:1993 Laser Class 1

EMC: EN 55022/A1+A2 (1995) / CISPR 22 (1997, 3. Ed.)A1+A2, Class A
EN 50082-1 (1997, 2. Ed.)
EN 55024-2 (1998) / IEC 1000-4-2 (1995), 4 kV CD, 8 kV AD
EN 55024-3 (1998) / IEC 1000-4-3 (1995), 3 V/m
EN 55024-4 (1998) / IEC 801-4-4 (1988), 1 kV Peak Power Lines
0,5 kV Signal Lines
EN 61000-3-2 (1995) / IEC 1000-3-2 (1995), Harmonics
EN 61000-3-3 (1995) / IEC 1000-3-3 (1994), Flicker

Supplementary Information:

The product herewith complies with the requirements of the following Directives and carries the CE marking accordingly:
the EMC Directive 89/336/EEC -the Low Voltage Directive 73/23/EEC (including 93/68/EEC)

The Manufacturer listed above declares that this product has been tested and found to comply with the limits of a Class A digital device, pursuant to Part 15 of FCC Rules. These limits are designed to provide reasonable protection against harmful interference. This equipment generates, uses, and can radiate radio frequency energy and, if not installed and used in accordance with the instruction manual, may cause harmful interference to radio communications. However, there is no guarantee that interference will not occur in a particular installation. If this equipment does cause harmful interference, which can be determined by turning the equipment off and on, the user is encouraged to try to correct the interference by one or more of the following measures: a) Reorient or relocate any receiving structures, b) Increase the separation between the equipment and units being interfered with, c) Connect the equipment into an outlet on a circuit different from that to which the unit being interfered with is connected, or d) Consult the dealer or an experienced radio/TV technician for help.

Change or modification of this equipment not expressly approved by Hewlett-Packard could void the user's authority to operate this equipment. Only use the cables, connectors, power cords, and accessories supplied with this equipment or expressly approved by Hewlett-Packard.

Storage Systems Division August, 1999 Greeley, Colorado, USA

For Regulatory Compliance Information ONLY, contact:

Australian: Product Regulations Manager, Hewlett-Packard, Australia Ltd., 31-41 Joseph Street, Blackburn, Victoria
3130, Australia

European: Your local Hewlett-Packard Sales and Service Office or Hewlett-Packard GmbH, Department TRE, Herrenberger Strasse
130, D-71304 Boblingen (FAX:+49-7031-14 3143)

USA: Product Regulations Manager, Hewlett-Packard Company, 700 71st Avenue, Greeley, CO 80634 USA,
(Phone: 970-350-5600).

United Kingdom Telecommunications Act 1984

The digital linear tape libraries are approved under Approval Number NS/G/1234/J/100003 for indirect connection to Public Telecommunication Systems within the United Kingdom.

Herstellerbescheinigung

Diese Information steht im Zusammenhang mit den Anforderungen der Maschinenlärn Information sverordnung vom 18 Januar 1991.

Schalldruckpegel $L_p < 70$ dB(A)

- am Arbeitsplatz
- Normaler betrieb
- Nach ISO 7779: 1988/EN 27779:1991 (Typprüfung)

English Translation of German Sound Emission Directive

This statement is provided to comply with the requirements of the German Sound Emission Directive, from January 18, 1991.

Sound pressure $L_p < 70$ dB(A)

- At operator position
- Normal operation
- According to ISO 7779: 1988/EN 27779: 1991 (type test)

Japanese Harmonics Statement

高調波ガイドライン適合品

Japanese VCCI Class B Statement

この装置は、情報処理装置等電波障害自主規制協議会（VCCI）の基準に基づくクラスB情報技術装置です。この装置は、家庭環境で使用することを目的としていますが、この装置がラジオやテレビジョン受信機に近接して使用されると、受信障害を引き起こすことがあります。
取り扱い説明書に従って正しい取り扱いをして下さい。

English Translation

This equipment is in the Class B category information technology equipment based on the rules of Voluntary Control Council For Interference by Information Technology Equipment (VCCI). Although aimed for residential area operation, radio interference may be caused when used near a radio or TV receiver. Read the instructions for correct operation.

Taiwan Class A Warning Statement

For HP DLT Library Model 718 (C6282L, C6280J, A5501A)

檢磁 3872H423

警告使用者：

這是甲類的資訊產品,在居住的環境中使用時,可能會造成射頻干擾,在這種情況下,使用者會被要求採取某些適當的對策.

Taiwan Class A Warning Statement

For HP DLT Library Model 418 (C6280F and C6280H)

檢磁 3872H422

警告使用者：

這是甲類的資訊產品,在居住的環境中使用時,可能會造成射頻干擾,在這種情況下,使用者會被要求採取某些適當的對策.

C **TapeAlert Messages**

Overview

This section contains information on TapeAlert messages, a diagnostic tool that monitors the drive's operations, checks media integrity, and sends messages via your backup software to warn you of existing or potential problems.

TapeAlert Messages and Descriptions

There are three types of flags, listed in order of severity. They are: information (I), warning (W), and critical (C). Information messages give explanations of a diagnostic situation. Warning messages appear when the risk of data loss exists. Critical messages are for the most severe problems and need to be addressed immediately.

Table C-1 TapeAlert Tape Drive Error Messages

No.	Flag	Type	Displayed Message	Additional Action Information
1	Read Warning	W	The tape is having problems reading data. No data has been lost, but there has been a reduction in the performance of the tape.	Back up information on to another tape and discard the defective tape. If the problem persists, call the tape drive supplier helpline.
2	Write Warning	W	The tape drive is having problems writing data. No data has been lost, but there has been a reduction in the capacity of the tape.	Back up information on to another tape and discard the defective tape. If the problem persists, call the tape drive supplier helpline.
3	Hard Error	W	The operation has stopped because an error has occurred while reading or writing data which the drive cannot correct.	Back up information on to another tape and try the operation again. If the problem persists, call the tape drive supplier helpline.
5	Read Failure	C	The tape is damaged or the drive is faulty. Call the tape drive supplier helpline.	Eject the tape and inspect for damage. Insert a new tape and try operation again.

TapeAlert Messages
TapeAlert Messages and Descriptions

Table C-1 TapeAlert Tape Drive Error Messages

No.	Flag	Type	Displayed Message	Additional Action Information
6	Write Failure	C	<p>The tape is from a faulty batch or the tape drive is faulty:</p> <ol style="list-style-type: none"> 1. Use a good tape to test the drive. 2. If the problem persists, call the tape drive supplier helpline. 	<p>Eject the tape and inspect for damage. Insert a new tape and try operation again.</p>
9	Write Protect	C	<p>You are trying to write to a write-protected cartridge. Remove the write-protection or use another tape.</p>	<p>Insert a new tape and try operation again.</p> <p>If the problem persists, call the tape drive supplier helpline.</p>
10	No Removal	I	<p>You cannot eject the cartridge because the tape is in use. Wait until the operation is complete before ejecting the cartridge.</p>	<p>If the problem persists, call the tape drive supplier helpline.</p>
11	Cleaning Media	I	<p>The tape in the drive is a cleaning cartridge. If you want to back up or restore, insert a data-grade tape.</p>	<p>If the problem persists, call the tape drive supplier helpline.</p>

Table C-1 TapeAlert Tape Drive Error Messages

No.	Flag	Type	Displayed Message	Additional Action Information
20	Clean Now	C	<p>The tape drive needs cleaning:</p> <ol style="list-style-type: none"> 1. If the operation has stopped, eject the tape and clean the drive. 2. If the operation has not stopped, wait for it to finish and then clean the drive. <p>Check the tape drive users manual for device specific cleaning instructions.</p>	<p>If the problem persists, call the tape drive supplier helpline.</p>
22	Expired Cleaning Media	C	<p>The last cleaning cartridge used in the tape drive has worn out:</p> <ol style="list-style-type: none"> 1. Discard the worn out cleaning cartridge. 2. Wait for the current operation to finish. 3. Then use a new cleaning cartridge. 	<p>Wait for the current operation to finish before discarding the cartridge.</p> <p>If the problem persists, call the tape drive supplier helpline.</p>

TapeAlert Messages
TapeAlert Messages and Descriptions

Table C-1 TapeAlert Tape Drive Error Messages

No.	Flag	Type	Displayed Message	Additional Action Information
31	Hardware B	C	<p>The tape drive has a hardware fault:</p> <ol style="list-style-type: none"> 1. Turn the tape drive off and then on again. 2. Restart the operation. 3. If the problem persists, call the tape drive supplier helpline. <p>Check the tape drive users manual for device specific instructions on turning the device power on and off.</p>	Power off the tape drive and attempt the operation again.
32	Interface	W	<p>The tape drive has a problem with the host interface:</p> <ol style="list-style-type: none"> 1. Check the cables and cable connections. 2. Restart the operation. 	If the problem persists, call the tape drive supplier helpline.
34	Download Fail	W	The firmware has failed because you have tried to use the incorrect firmware for this tape drive. Obtain the correct firmware and try again.	Call the tape drive supplier helpline for more information.

Table C-2 TapeAlert Tape Library Error Messages

No.	Flag	Type	Displayed Message	Additional Action Information
1	Hardware A	C	<p>The library mechanism is having difficulty communicating with the drive.</p> <ol style="list-style-type: none"> 1. Turn the library off then on. 2. Restart the operation. 3. If the problem persists, call the library supplier helpline. 	<p>Inspect the library to make sure all cable and power connections are secure and tapes inserted correctly.</p>
2	Hardware B	W	<p>Inspect the library to make sure all connections are secure and tapes inserted correctly.</p>	<p>There is a problem with the library mechanism. If the problem persists, call the library supplier helpline.</p>
3	Hardware C	C	<p>The library has a hardware fault:</p> <ol style="list-style-type: none"> 1. Reset the library. 2. Restart the operation. <p>Check the library users manual for device specific instructions on resetting the device.</p>	<p>If the problem persists, call the library supplier helpline.</p>

TapeAlert Messages
TapeAlert Messages and Descriptions

Table C-2 TapeAlert Tape Library Error Messages

No.	Flag	Type	Displayed Message	Additional Action Information
4	Hardware D	C	<p>The library has a hardware fault:</p> <ol style="list-style-type: none"> 1. Turn the library off and then on again. 2. Restart the operation. 3. If the problem persists, call the library supplier helpline. <p>Check the library users manual for device specific instructions on turning the device power on and off.</p>	<p>Inspect the library to make sure all connections are secure and tapes inserted correctly.</p>
6	Library Interface	C	<p>The library has a problem with the host interface:</p> <ol style="list-style-type: none"> 1. Check the cables and cable connections. 2. Restart the operation. 	<p>If the problem persists, call the library supplier helpline.</p>
13	Library Pick Retry	W	<p>There is a potential problem with a drive ejecting cartridges short or with the library mechanism picking a cartridge from a slot. This warning is for information purposes only. No action needs to be taken at this time. If the problem persists, call the tape drive supplier helpline.</p>	<p>Inspect the library to see if any visible problems exist.</p> <p>Insert a cartridge and try the operation again.</p>

Table C-2 TapeAlert Tape Library Error Messages

No.	Flag	Type	Displayed Message	Additional Action Information
14	Library Place Retry	W	There is a potential problem with the library mechanism placing a cartridge into a slot. This warning is for information purposes only. No action needs to be taken at this time. If the problem persists, call the tape drive supplier helpline.	Inspect the library to see if any visible problems exist. Insert a cartridge and try the operation again.
15	Library Load Retry	W	There is a potential problem with a drive or the library mechanism loading cartridges, or an incompatible cartridge.	Inspect the library to see if any visible problems exist. Insert a cartridge and try the operation again. Inspect the cartridge to verify compatibility. Call the library supplier helpline if problems persist.

TapeAlert Messages
TapeAlert Messages and Descriptions

Table C-2 TapeAlert Tape Library Error Messages

No.	Flag	Type	Displayed Message	Additional Action Information
16	Library Door	C	<p>The operation has failed because the library door is open:</p> <ol style="list-style-type: none"> 1. Clear any obstructions from the library door. 2. Eject any magazine and then insert it again. 3. If the fault does not clear, turn the library off and then on again. 4. If the problem persists, call the library supplier helpline. 	<p>Inspect the library to see if any visible problems exist.</p> <p>Insert a cartridge and try the operation again.</p>
17	Library Mailslot	C	<p>There is a mechanical problem with the library media import/export mailslot.</p>	<p>Inspect the library to see if any visible problems exist. Insert a cartridge and try the operation again. Call the library supplier helpline.</p>
18	Library Magazine	C	<p>The library cannot operate without the magazine.</p> <ol style="list-style-type: none"> 1. Insert the magazine into the library. 2. Restart the operation. 	<p>Refer to user's manual for library operation instructions about inserting magazines.</p> <p>Call the library supplier helpline.</p>

Table C-2 TapeAlert Tape Library Error Messages

No.	Flag	Type	Displayed Message	Additional Action Information
20	Library Security Mode	I	The security mode of the library has been changed. The library has either been put into secure mode, or the library has exited the secure mode. This is for information purposes only. No action is required.	Check the user's manual to verify library configuration.
21	Library Offline	I	The library has been manually turned offline and is unavailable for use.	Power the library on to use.
22	Library Drive Offline	I	A drive inside the library has been taken offline. This is for information purposes only. No action is required.	If drive is desired for use, power the library on.
23	Library Scan Retry	I	There is a potential problem with the barcode label or the scanner hardware in the library mechanism.	Eject the tape and verify that the barcode label is in place and undamaged. Insert the tape and retry the operation. Call the library supplier helpline.

TapeAlert Messages
TapeAlert Messages and Descriptions

Table C-2 TapeAlert Tape Library Error Messages

No.	Flag	Type	Displayed Message	Additional Action Information
24	Library Inventory	C	<p>The library has detected an inconsistency in its inventory.</p> <ol style="list-style-type: none"> 1. Redo the library inventory to correct inconsistency. 2. Restart the operation. <p>Check the applications users manual or the hardware users manual for specific instructions on redoing the library inventory.</p>	<p>Call the library supplier helpline if problems persist.</p>
25	Library Illegal Operation	W	<p>A library operation has been attempted that is invalid at this time.</p>	<p>Call the library supplier helpline if problems persist.</p>

D **Installing an Autoloader into a Non-HP Rack**

Mounting the Autoloader in a Non-HP Rack

This rackmount kit fits all standard 19-inch racks that have a depth between 25 and 34 inches.

Tools and Components

Before you begin, make sure you have the following:

Tools:

#2 Phillips screwdriver

Kit Components (parts are labeled for easy identification):

-
- | | |
|--------------------------------------|------------------------------------|
| 1. Installation poster (Qty 1) | 6. 10-32 clipnuts (Qty 10) |
| 2. Template (Qty 1) | 7. Support bezel (Qty 1) |
| 3. Cable ties (Qty 4) | 8. Filler panel (Qty 1) |
| 4. M4 x 10 mm pan phillips (Qty 6) | 9. Shelf and rail assembly (Qty 1) |
| 5. 10-32 x 5/8 pan phillips (Qty 10) | |

NOTE

The rack kit may contain extra parts.

Figure D-1

Rack Kit Parts

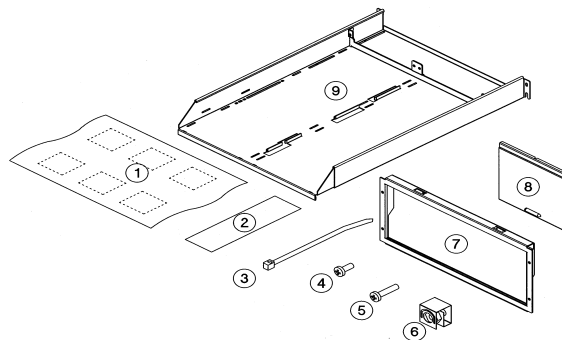

Mounting the Autoloader

1. Facing the front of the rack and using the template as a guide, install four clipnuts (two in each rail) above any existing products (Figure D-2).

TIP

For a level shelf, ensure that the screws are in the same position on the right and left rail.

NOTE

Your rack might look different from the illustrations.

2. Using the template as a guide, install two clipnuts into each back rail on the rack. The back lower clipnuts should be located one hole above the front lower clipnuts (Figure D-2).
3. Position the holes on the support bezel over the front clipnuts, then install and tighten four 10-32 screws.
4. Loosely install two 10-32 screws into the back lower clipnuts.

Figure D-2 Clipnut and Screw Installation

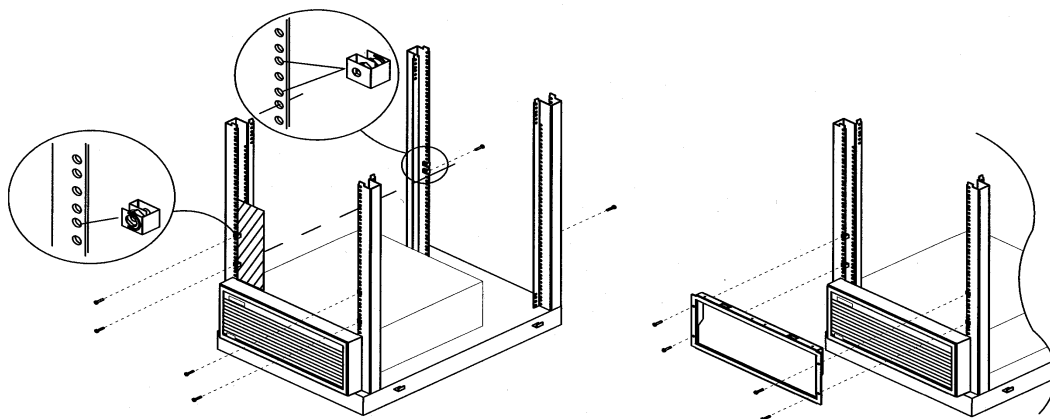

Installing an Autoloader into a Non-HP Rack

Mounting the Autoloader in a Non-HP Rack

5. Before installing the shelf, adjust the shelf depth to fit your rack (Figure D-3). The shelf can be adjusted for 25- to 34- inch racks. To customize the fit, measure the rack depth from the front rail to the back rail.
 - a. Remove the four preset screws from the shelf.
 - b. Slide the side rails back until the shelf depth is the same measurement as the rack depth.
 - c. Loosely thread a screw into the corresponding hole or slot, as well as the holes near the shelf backstop.

Do not tighten the screws until you install the shelf (Figure D-3).

Figure D-3 Customizing the Shelf Depth

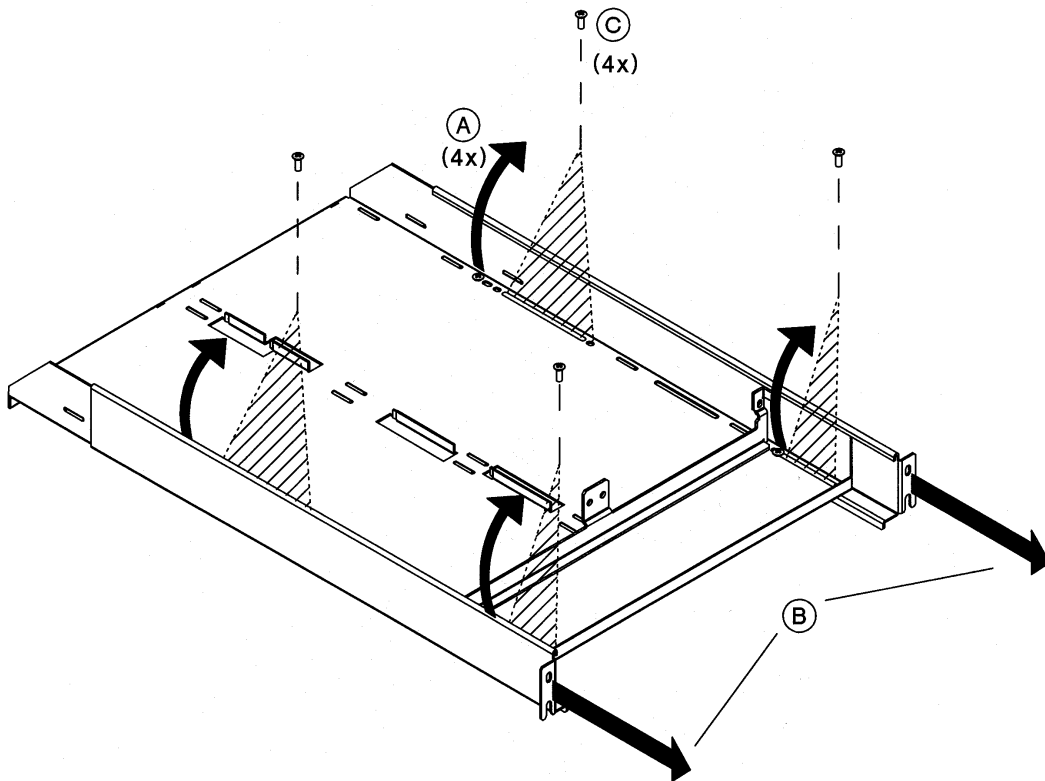

- Slide the shelf through the back of the rack until the front lip is over the bezel and the rear portion of the shelf slides over the back screws (Figure D-4).

Figure D-4 Shelf Installation

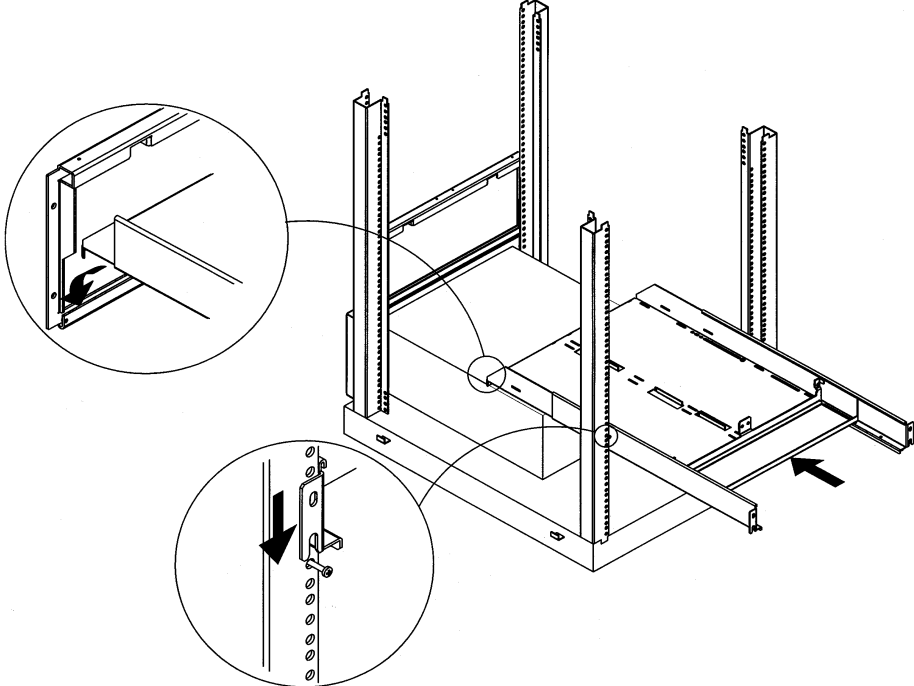

NOTE Have a second person stand at the front of the rack to help guide the front lip of the shelf between the slots on the bezel.

CAUTION Ensure that installation in your rack cabinet does not create an unstable condition.

Installing an Autoloader into a Non-HP Rack
Mounting the Autoloader in a Non-HP Rack

7. To secure the shelf to the rack, install and tighten two screws (one on each side) into the upper clipnut on the back of the shelf (Figure D-5).
 - a. Tighten the four screws on the shelf.
 - b. Tighten the four screws on the back of the rack.

Figure D-5 Tighten the Screws

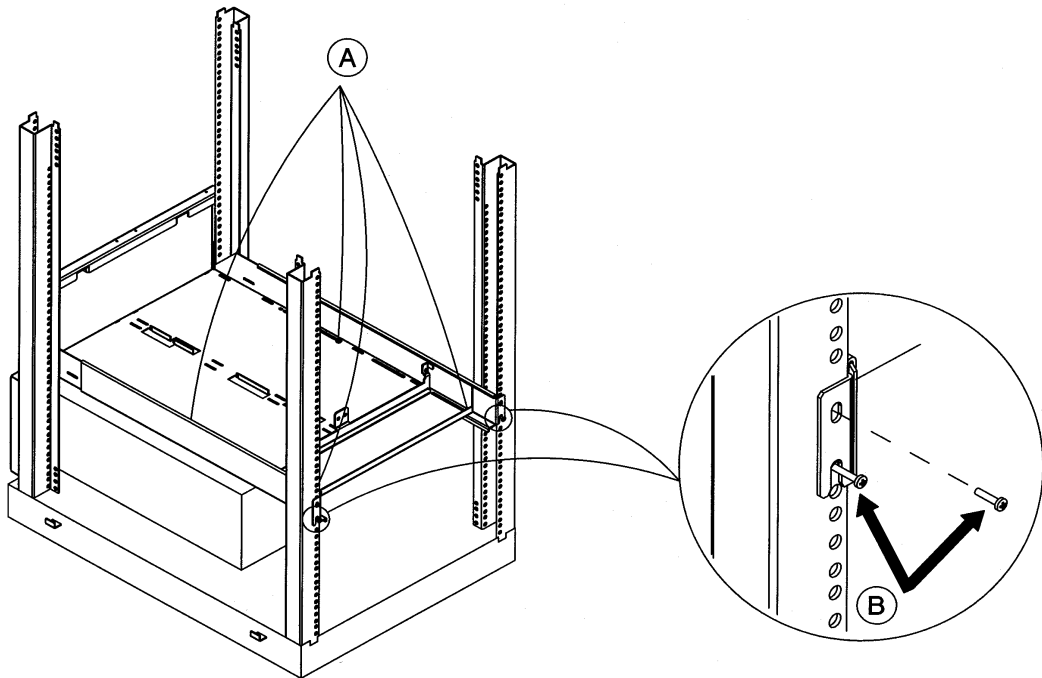

8. Decide on the location for the Autoloader. The filler panel will be installed on the other side if you are installing one Autoloader (Figure D-6).
9. Align the filler panel to the edge of the support bezel and insert it up into the track.

The tabs on the bottom of the filler panel should fit into the corresponding holes on the shelf. The tab in the top of the filler panel will hold the filler panel in place. If the panel is not correctly installed, it will not load.

Figure D-6 Filler Panel Installation

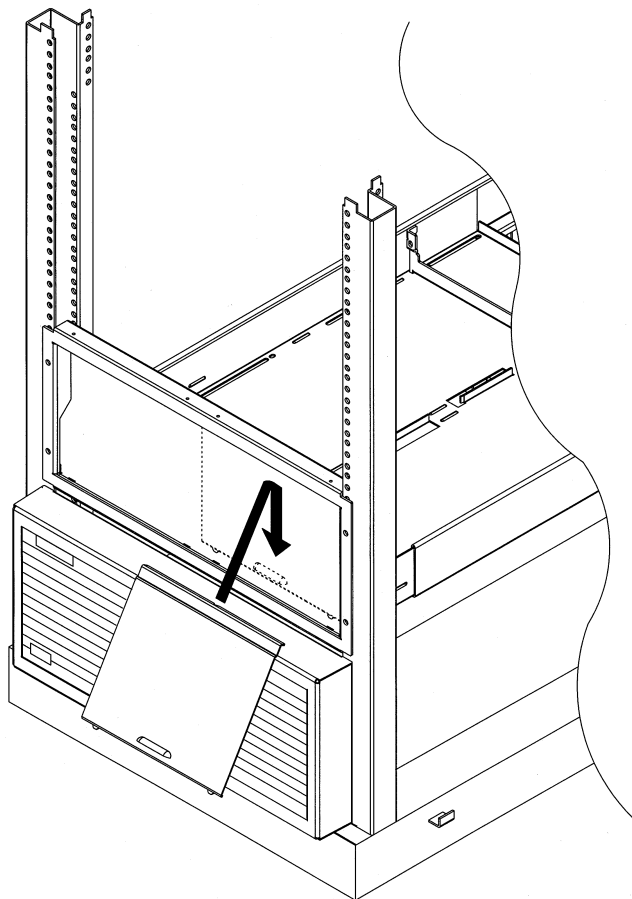

Installing an Autoloader into a Non-HP Rack

Mounting the Autoloader in a Non-HP Rack

10. Remove the unit's cover and feet. See Figure 1-8 on page 1-12 for the procedure.
11. From the front of the bezel, slide the Autoloader into the shelf until it rests firmly against the support bracket.
12. Secure the unit by installing two M4x10 mm screws through the support bracket and into the rear panel (Figure D-7).
13. After connecting the external cables, secure the cables to the side of the rack by following the steps in "Cable Management" on page D-9.

NOTE

Save the remaining screws for a possible second Autoloader installation.

Figure D-7 **Securing the Autoloader**

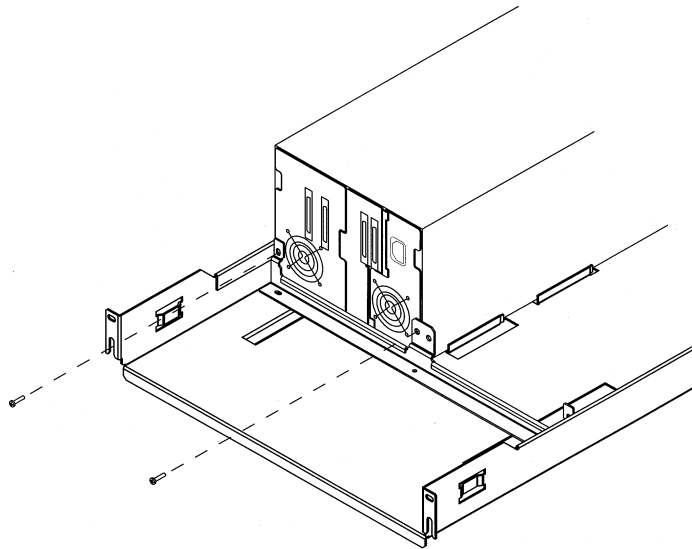

CAUTION

Be certain that the temperature of the rack cabinet does not exceed the maximum temperature of 104°F or 40C.

Cable Management

CAUTION

Ensure that the SCSI and power cables are properly routed and secured on rackmounted Autoloaders so that they do not interfere with other moveable rackmounted products. Failure to properly route cables could damage them.

1. After connecting the external cables in “Connecting the Autoloader” on page 1-15, thread a cable tie through the metal rail inside the rack (Figure D-8).
2. Gently pull the cables toward the nearest cable tie to secure them to the rack.
3. Route the cables through the rack so that they do not interfere with other rackmounted products.

Figure D-8 Cable Management

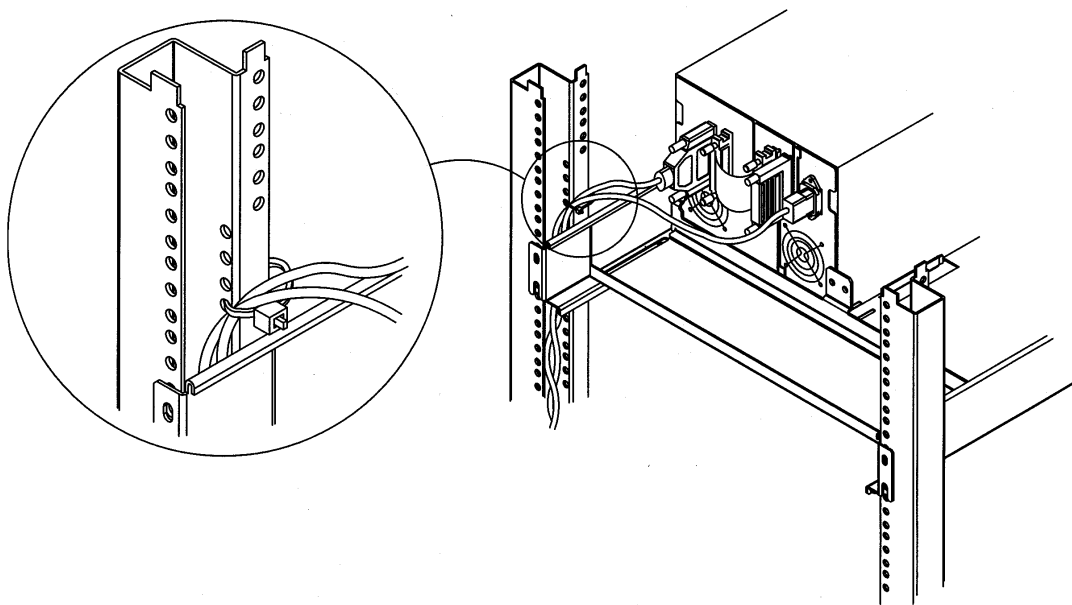

Installing an Autoloader into a Non-HP Rack
Mounting the Autoloader in a Non-HP Rack

A

- accessing the autoloader, 2-17
- accessories, A-2
- activity indicators, 2-10
- activity light, 2-8
- adapter
 - guidelines, 1-19
- adapter interfaces, 1-19
- ADMIN * menu
 - changing the password, 2-18
- administration menu
 - information, 2-15
- administration menu
 - clean drive, 2-15
 - configurations, 2-15
 - firmare, 2-15
 - override door, 2-15
 - SCSI IDs, 2-15
 - tests, 2-15
- autoloader
 - moving, 1-20—1-21
 - shipping, 1-22

B

- bar code labels
 - labeling cartridges, 3-3
 - labeling magazines, 3-4
- bezel, 1-9
- bezel installation, 1-9
- buttons. See selection buttons

C

- cable connections, 1-15—1-17
- cabling
 - only peripheral, 1-16
 - with other peripherals, 1-17
- changing the password, 2-18
- choosing a location, 1-6
- cleaning errors, 2-23
- cleaning the drives, 2-23
- clearance, 1-6
- clipnuts, 1-8

configuration options

- listing of, 2-24—2-25

configurations

- autoload, 2-25
- clear odometers, 2-24
- compress, 2-25
- new password, 2-24
- power secure, 2-25
- recovery, 2-24, 2-25
- restore defaults, 2-24
- SCSI log, 2-24
- secure, 2-24

configurations circular, 2-25

control panel

- tests, 2-28—2-32

control panel buttons, 2-8

conventions

- typographical, v

customer care, A-3

customer support, A-3

D

- display, 2-8
- display window
 - description of, 2-8
- display window messages, 2-9
- door
 - opening, 2-3
- drive cleaning
 - errors, 2-23
 - troubleshooting, 2-23
- drive status, 2-10

E

- entering the password, 2-17
- error codes, 2-43
- error logs, 2-27
- errors, 2-42
 - messages, 2-42
- external cables, 1-15

F

- filler panel, 1-11, D-7
- front panel, 2-8
 - display, 2-8
 - keys, 2-8
- front panel tests, 2-28

H

- high voltage differential scsi, 1-19
- HVDS, 1-19

I

- indicators
 - activity, 2-10
- information logs, 2-27
- inserting a magazine, 2-5
- installation overview, 1-4
- interface types, 1-19
- internal tests, 2-28—2-32

J

- jumper cable, 1-3

L

- labeling tapes, 3-3, 3-4
- LED, 2-8
- loading a magazine, 2-5
- loading internal slots, 2-6
- loading tapes, 2-3—2-5
- location
 - air quality, 1-6
 - clearance, 1-6
 - temperature, 1-6
- location criteria, 1-6
- logs
 - drive, 2-27
 - errors, 2-27
 - firmware, 2-27
 - loader, 2-27
 - odometers, 2-27
- low voltage differential scsi, 1-19

LVDS, 1-19

M

magazine
 loading, 2-5
magazines
 labeling, 3-4
menu choices, 2-12
 admin, 2-12
 load tape, 2-12
 release door, 2-12
 unload tape, 2-12
menu structure, 2-11
menu tree, 2-11
moving the autoloader, 1-20—1-21

O

opening the door, 2-3
 alternate approach, 2-3
ordering supplies, A-2

P

parts, 1-3, A-2
 adapter, 1-3, 1-19
 cables, 1-3
 live trial software, 1-3
 SureStore CD, 1-3
 tapes, 1-3
 terminator, 1-3
password, 2-18
 entering, 2-17
 setting new, 2-18
password, changing, 2-18
password-protected functions, 2-15
physical specifications, 1-6
powering on, 1-18
problems, troubleshooting table, 2-34—2-38
product components, 1-3

R

rackmount installation, 1-7—1-14,
 D-2—D-8
 cable management, D-9
 clipnuts and screws, 1-8, D-3
 filler panel, D-7
 shelf, 1-10, D-5
rackmounting
 bezel, 1-9
 clipnuts, 1-8
 components, 1-7
 filler panel, 1-11
 non-HP rack, D-2—D-8
 securing, 1-14
 tools, 1-7
rear pane
 overview, 1-5
rear panel, 1-5
 configurations, 1-5
receiving service, A-3
running tests, 2-28

S

SCSI addresses, viewing, 2-20
SCSI bus adapter, 1-19
SCSI cabling specifications, 1-19
SCSI IDs, 2-15
security code, setting, 2-21
setting SCSI addresses, 2-19—2-20
shipping the autoloader, 1-22
specifications, 1-6
status indicators, 2-10
supplies, A-2
support, A-3
 fax, A-3
 information needed, A-3
 online, A-3
 telephone, A-5

T

tape drives
 cleaning, 2-23

tape status, 2-9

TapeAlert

 messages, C-3—C-12

tapes

 cleaning issues, 2-23
 labeling, 3-3
 loading, 2-5—2-7
 maintenance of, 3-6
 write-protecting, 3-5
technical specifications, 1-6
testing the autoloader, 2-28
top-level menus, 2-12
troubleshooting, 2-34—2-41
 error messages, 2-36
 host, 2-35
 magazine, 2-40
 power, 2-34
 stuck tapes, 2-38

type styles in this book, v

U

understanding error messages, 2-42
unloading tapes, 2-7

V

VCCI statement, B-5

W

Warranty, ii