



Sun™ Ultra™ 60 Service Manual

Sun Microsystems, Inc.
901 San Antonio Road
Palo Alto, CA 94303-4900 U.S.A.
650-960-1300

Part No. 805-1709-12
Revision A, August 2001

Send comments about this document to: docfeedback@sun.com

Copyright 2001 Sun Microsystems, Inc., 901 San Antonio Road, Palo Alto, CA 94303-4900 U.S.A. All rights reserved.

This product or document is distributed under licenses restricting its use, copying, distribution, and decompilation. No part of this product or document may be reproduced in any form by any means without prior written authorization of Sun and its licensors, if any. Third-party software, including font technology, is copyrighted and licensed from Sun suppliers.

Parts of the product may be derived from Berkeley BSD systems, licensed from the University of California. UNIX is a registered trademark in the U.S. and other countries, exclusively licensed through X/Open Company, Ltd.

Sun, Sun Microsystems, the Sun logo, AnswerBook2, docs.sun.com, and Solaris are trademarks, registered trademarks, or service marks of Sun Microsystems, Inc. in the U.S. and other countries. All SPARC trademarks are used under license and are trademarks or registered trademarks of SPARC International, Inc. in the U.S. and other countries. Products bearing SPARC trademarks are based upon an architecture developed by Sun Microsystems, Inc. The Energy Star logo is a registered trademark of EPA.

The OPEN LOOK and Sun™ Graphical User Interface was developed by Sun Microsystems, Inc. for its users and licensees. Sun acknowledges the pioneering efforts of Xerox in researching and developing the concept of visual or graphical user interfaces for the computer industry. Sun holds a non-exclusive license from Xerox to the Xerox Graphical User Interface, which license also covers Sun's licensees who implement OPEN LOOK GUIs and otherwise comply with Sun's written license agreements.

Federal Acquisitions: Commercial Software—Government Users Subject to Standard License Terms and Conditions.

DOCUMENTATION IS PROVIDED "AS IS" AND ALL EXPRESS OR IMPLIED CONDITIONS, REPRESENTATIONS AND WARRANTIES, INCLUDING ANY IMPLIED WARRANTY OF MERCHANTABILITY, FITNESS FOR A PARTICULAR PURPOSE OR NON-INFRINGEMENT, ARE DISCLAIMED, EXCEPT TO THE EXTENT THAT SUCH DISCLAIMERS ARE HELD TO BE LEGALLY INVALID.

Copyright 2001 Sun Microsystems, Inc., 901 San Antonio Road, Palo Alto, CA 94303-4900 Etats-Unis. Tous droits réservés.

Ce produit ou document est distribué avec des licences qui en restreignent l'utilisation, la copie, la distribution, et la décompilation. Aucune partie de ce produit ou document ne peut être reproduite sous aucune forme, par quelque moyen que ce soit, sans l'autorisation préalable et écrite de Sun et de ses bailleurs de licence, s'il y en a. Le logiciel détenu par des tiers, et qui comprend la technologie relative aux polices de caractères, est protégé par un copyright et licencié par des fournisseurs de Sun.

Des parties de ce produit pourront être dérivées des systèmes Berkeley BSD licenciés par l'Université de Californie. UNIX est une marque déposée aux Etats-Unis et dans d'autres pays et licenciée exclusivement par X/Open Company, Ltd.

Sun, Sun Microsystems, le logo Sun, AnswerBook2, docs.sun.com, et Solaris sont des marques de fabrique ou des marques déposées, ou marques de service, de Sun Microsystems, Inc. aux Etats-Unis et dans d'autres pays. Toutes les marques SPARC sont utilisées sous licence et sont des marques de fabrique ou des marques déposées de SPARC International, Inc. aux Etats-Unis et dans d'autres pays. Les produits portant les marques SPARC sont basés sur une architecture développée par Sun Microsystems, Inc.

L'interface d'utilisation graphique OPEN LOOK et Sun™ a été développée par Sun Microsystems, Inc. pour ses utilisateurs et licenciés. Sun reconnaît les efforts de pionniers de Xerox pour la recherche et le développement du concept des interfaces d'utilisation visuelle ou graphique pour l'industrie de l'informatique. Sun détient une licence non exclusive de Xerox sur l'interface d'utilisation graphique Xerox, cette licence couvrant également les licenciés de Sun qui mettent en place l'interface d'utilisation graphique OPEN LOOK et qui en outre se conforment aux licences écrites de Sun.

LA DOCUMENTATION EST FOURNIE "EN L'ETAT" ET TOUTES AUTRES CONDITIONS, DECLARATIONS ET GARANTIES EXPRESSES OU TACITES SONT FORMELLEMENT EXCLUES, DANS LA MESURE AUTORISEE PAR LA LOI APPLICABLE, Y COMPRIS NOTAMMENT TOUTE GARANTIE IMPLICITE RELATIVE A LA QUALITE MARCHANDE, A L'APTITUDE A UNE UTILISATION PARTICULIERE OU A L'ABSENCE DE CONTREFAÇON.



Adobe PostScript

Contents

Preface xvii

1. Product Description 1-1

1.1 I/O Devices 1-3

1.2 System Unit Features 1-3

1.3 System Unit Components 1-5

2. SunVTS Overview 2-1

2.1 SunVTS Description 2-1

2.2 SunVTS Operation 2-2

3. Power-On Self-Test 3-1

3.1 POST Overview 3-2

3.2 Pre-POST Preparation 3-2

3.2.1 Setting Up a Tip Connection 3-3

3.2.2 Verifying the Baud Rate 3-4

3.3 Initializing POST 3-5

3.4 Maximum and Minimum Levels of POST 3-6

3.4.1 `diag-level` Variable Set to `max` 3-7

3.4.2 `diag-level` Variable Set to `min` 3-14

- 3.4.3 POST Progress and Error Reporting 3-18
- 3.5 Bypassing POST 3-21
- 3.6 Additional Keyboard Control Commands 3-22
- 3.7 System and Keyboard LEDs 3-22
- 3.8 Initializing Motherboard POST 3-23
- 4. Troubleshooting Procedures 4-1**
 - 4.1 Power-On Failure 4-2
 - 4.2 Video Output Failure 4-3
 - 4.3 Disk Drive or CD-ROM Drive Failure 4-3
 - 4.4 Power Supply Test 4-5
 - 4.5 DIMM Failure 4-7
 - 4.6 OpenBoot PROM On-Board Diagnostics 4-8
 - 4.6.1 watch-clock 4-9
 - 4.6.2 watch-net and watch-net-all 4-9
 - 4.6.3 probe-scsi and probe-scsi-all 4-10
 - 4.6.4 test *alias name, device path*, -all 4-11
 - 4.6.5 UPA Graphics Card 4-12
 - 4.7 OpenBoot Diagnostics 4-13
 - 4.7.1 PCI/Cheerio 4-15
 - 4.7.2 EBus DMA/TCR Registers 4-16
 - 4.7.3 Ethernet 4-16
 - 4.7.4 Keyboard 4-17
 - 4.7.5 Mouse 4-18
 - 4.7.6 Floppy 4-18
 - 4.7.7 Parallel Port 4-18
 - 4.7.8 Serial Port A 4-19
 - 4.7.9 Serial Port B 4-21

4.7.10	NVRAM	4-22
4.7.11	Audio	4-22
4.7.12	SCSI	4-23
4.7.13	All Above	4-23
5.	Safety and Tool Requirements	5-1
5.1	Safety Requirements	5-2
5.2	Symbols	5-2
5.3	Safety Precautions	5-3
5.3.1	Modification to Equipment	5-3
5.3.2	Placement of a Sun Product	5-3
5.3.3	Power Cord Connection	5-3
5.3.4	Electrostatic Discharge	5-4
5.3.5	Lithium Battery	5-4
5.4	Tools Required	5-4
6.	Power On and Off	6-1
6.1	Powering On the System Unit	6-2
6.2	Powering Off the System Unit	6-3
7.	Internal Access	7-1
7.1	Removing the Side Access Cover	7-2
7.2	Attaching the Wrist Strap	7-3
7.3	Replacing the Side Access Cover	7-4
8.	Major Subassemblies	8-1
8.1	Power Supply	8-2
8.1.1	Removing the Power Supply	8-2
8.1.2	Replacing the Power Supply	8-3

- 8.2 PCI Fan Assembly 8-5
 - 8.2.1 Removing the PCI Fan Assembly 8-5
 - 8.2.2 Replacing the PCI Fan Assembly 8-6
- 8.3 Hard Drive Bay With SCSI Assembly 8-7
 - 8.3.1 Removing the SCSI Drive Bay 8-7
 - 8.3.2 Replacing the SCSI Drive Bay 8-9
- 8.4 Cable Assemblies 8-11
 - 8.4.1 Removing the Peripheral Power Cable Assembly 8-11
 - 8.4.2 Replacing the Peripheral Power Cable Assembly 8-12
 - 8.4.3 Removing the Diskette Drive Cable Assembly 8-12
 - 8.4.4 Replacing the Diskette Drive Cable Assembly 8-13
- 8.5 EMI Filler Panels 8-14
 - 8.5.1 Removing an EMI Filler Panel 8-14
 - 8.5.2 Replacing an EMI Filler Panel 8-15
- 8.6 Chassis Foot 8-16
 - 8.6.1 Removing the Foot 8-16
 - 8.6.2 Replacing the Foot 8-17
- 8.7 Speaker Assembly 8-17
 - 8.7.1 Removing the Speaker Assembly 8-17
 - 8.7.2 Replacing the Speaker Assembly 8-18
- 8.8 DC Switch Assembly 8-19
 - 8.8.1 Removing the DC Switch Assembly 8-19
 - 8.8.2 Replacing the DC Switch Assembly 8-31
- 8.9 CPU Fan Assembly 8-36
 - 8.9.1 Removing the CPU Fan Assembly 8-36
 - 8.9.2 Replacing the CPU Fan Assembly 8-37
- 8.10 Shroud Assembly 8-38

- 8.10.1 Removing the Shroud Assembly 8-38
- 8.10.2 Replacing the Shroud Assembly 8-39
- 9. Storage Devices 9-1**
 - 9.1 Hard Drive 9-2
 - 9.1.1 Removing a Hard Drive 9-2
 - 9.1.2 Replacing a Hard Drive 9-3
 - 9.2 Removable Media Assembly Drive 9-4
 - 9.2.1 Removing the RMA 9-4
 - 9.2.2 Removing the CD-ROM Drive or Any X-Option Tape Drive 9-6
 - 9.2.3 Replacing the CD-ROM Drive or Any X-Option Tape Drive 9-8
 - 9.2.4 Removing the Diskette Drive 9-8
 - 9.2.5 Replacing the Diskette Drive 9-9
 - 9.2.6 Replacing the RMA 9-9
- 10. Motherboard and Component Replacement 10-1**
 - 10.1 CPU Module 10-2
 - 10.1.1 Special Considerations for Systems With 450 MHz CPU Modules 10-2
 - 10.1.2 Removing the CPU Module 10-2
 - 10.1.3 Replacing the CPU Module 10-4
 - 10.2 NVRAM/TOD 10-5
 - 10.2.1 Removing the NVRAM/TOD 10-5
 - 10.2.2 Replacing the NVRAM/TOD 10-6
 - 10.3 PCI Card 10-7
 - 10.3.1 Removing a PCI Card 10-7
 - 10.3.2 Replacing a PCI Card 10-9
 - 10.4 UPA Graphics Card 10-10
 - 10.4.1 Removing the UPA Graphics Card 10-10

10.4.2	Replacing the UPA Graphics Card	10-11
10.5	DIMM	10-12
10.5.1	Removing a DIMM	10-13
10.5.2	Replacing a DIMM	10-15
10.6	Audio Card	10-16
10.6.1	Removing the Audio Card	10-16
10.6.2	Replacing the Audio Card	10-18
10.7	Motherboard	10-19
10.7.1	Removing a Motherboard	10-20
10.7.2	Replacing a Motherboard	10-23
11.	Illustrated Parts List	11-1
A.	Product Specifications	A-1
A.1	Physical Specifications	A-2
A.2	Electrical Specifications	A-2
A.3	Environmental Requirements	A-3
B.	Signal Descriptions	B-1
B.1	Keyboard/Mouse and Serial Ports A and B	B-2
B.1.1	Keyboard/Mouse Connector	B-2
B.1.2	Serial Port A and B (RS-423/RS-232) Connectors	B-3
B.2	Twisted-Pair Ethernet Connector	B-5
B.3	UltraSCSI Connector	B-6
B.4	Audio Connectors	B-10
B.5	Parallel Port Connector	B-11
B.6	Media Independent Interface Connector	B-14
B.7	UPA Graphics Card Connector	B-16

C. Functional Description C-1

- C.1 System Unit C-2
 - C.1.1 UPA Interconnect C-4
 - C.1.2 System Controller C-5
 - C.1.3 PCI Bus C-6
 - C.1.4 EBus2 Devices C-7
 - C.1.5 UltraSPARC II Processor C-8
 - C.1.6 Memory System C-9
 - C.1.7 Graphics and Imaging C-14
 - C.1.8 Peripherals C-15
 - C.1.9 Other RMA Storage Device X-Options C-19
 - C.1.10 Keyboard and Mouse, Diskette, and Parallel Port C-19
 - C.1.11 Serial Port C-22
 - C.1.12 Ethernet C-24
 - C.1.13 Audio Card and Connector C-28
 - C.1.14 SCSI C-30
 - C.1.15 ASICs C-33
 - C.1.16 SuperIO C-36
- C.2 Power Supply C-36
 - C.2.1 Control Signals C-37
 - C.2.2 Built-In Speaker C-42
 - C.2.3 Standard System Facilities C-43
- C.3 Motherboard C-43
- C.4 Jumper Descriptions C-45
 - C.4.1 Serial Port Jumpers C-46
 - C.4.2 Flash PROM Jumpers C-47
- C.5 Enclosure C-47
 - C.5.1 Enclosure Basics C-47
 - C.5.2 Enclosure Features C-48
- C.6 Environmental Compliance C-48
- C.7 Agency Compliance C-48

C.8 Energy Star Software Support C-48

Glossary G-1

Index ix-1

Figures

FIGURE 1-1	Ultra 60 Desktop Workstation	1-2
FIGURE 1-2	System Unit Front View	1-4
FIGURE 1-3	System Unit Rear View	1-5
FIGURE 3-1	Setting Up a TIP Connection	3-3
FIGURE 3-2	Sun Type-5 Keyboard	3-5
FIGURE 4-1	Power Supply Connector J2901	4-6
FIGURE 4-2	Power Supply Connector J2902	4-6
FIGURE 4-3	Power Supply Connector J2903	4-7
FIGURE 6-1	System Unit Power-On (Front Panel)	6-2
FIGURE 6-2	Sun Type-5 Keyboard	6-3
FIGURE 6-3	System Unit Power-Off (Front Panel)	6-4
FIGURE 7-1	Lock Block Location	7-2
FIGURE 7-2	Removing the Side Access Cover	7-3
FIGURE 7-3	Attaching the Wrist Strap to the Chassis	7-4
FIGURE 7-4	Replacing the Side Access Cover	7-5
FIGURE 8-1	Removing and Replacing the Power Supply (Part 1 of 2)	8-3
FIGURE 8-2	Removing and Replacing the Power Supply (Part 2 of 2)	8-4
FIGURE 8-3	Removing and Replacing the PCI Fan Assembly	8-6
FIGURE 8-4	Removing and Replacing the SCSI Drive Bay	8-9
FIGURE 8-5	Removing and Replacing the Bezel EMI Filler Panel	8-15

FIGURE 8-6	Removing and Replacing the RMA EMI Filler Panel	8-15
FIGURE 8-7	Removing and Replacing the Chassis Foot	8-16
FIGURE 8-8	Removing and Replacing the Speaker Assembly	8-18
FIGURE 8-9	System Unit Power-Off (Front Panel)	8-20
FIGURE 8-10	Lock Block Location	8-20
FIGURE 8-11	Removing the Side Access Cover	8-21
FIGURE 8-12	Attaching the Wrist Strap to the Chassis	8-22
FIGURE 8-13	Removing and Replacing a PCI Card	8-23
FIGURE 8-14	Removing and Replacing a UPA Graphics Card	8-24
FIGURE 8-15	Removing and Replacing the PCI Fan Assembly	8-25
FIGURE 8-16	Removing and Replacing a Hard Drive	8-26
FIGURE 8-17	Removing and Replacing the SCSI Drive Bay	8-28
FIGURE 8-18	DC Switch Assembly Cable Routing	8-29
FIGURE 8-19	Removing and Replacing the Front Panel	8-30
FIGURE 8-20	Removing and Replacing the Front Panel DC Switch Assembly	8-31
FIGURE 8-21	Replacing the Side Access Cover	8-34
FIGURE 8-22	System Unit Power-On (Front Panel)	8-35
FIGURE 8-23	Sun Type-5 Keyboard	8-35
FIGURE 8-24	Removing and Replacing the CPU Fan Assembly	8-37
FIGURE 8-25	Removing and Replacing the Shroud Assembly	8-39
FIGURE 9-1	Removing and Replacing a Hard Drive	9-3
FIGURE 9-2	Removing and Replacing a RMA Drive (Part 1 of 2)	9-6
FIGURE 9-3	Removing and Replacing a RMA Drive (Part 2 of 2)	9-7
FIGURE 10-1	Removing and Replacing the CPU Module	10-3
FIGURE 10-2	Removing and Replacing the NVRAM/TOD	10-6
FIGURE 10-3	Removing and Replacing a PCI Card	10-8
FIGURE 10-4	Removing and Replacing a UPA Graphics Card	10-11
FIGURE 10-5	Removing and Replacing a DIMM	10-14
FIGURE 10-6	Removing and Replacing the Audio Card	10-18
FIGURE 10-7	Removing and Replacing the Motherboard (Part 1 of 2)	10-21

FIGURE 10-8	Removing and Replacing the Motherboard (Part 2 of 2)	10-22
FIGURE 10-9	Location of the Motherboard Serial Port Jumpers	10-24
FIGURE 10-10	Identifying Jumper Pins	10-24
FIGURE 11-1	System Unit Exploded View	11-2
FIGURE B-1	Keyboard/Mouse Connector Pin Configuration	B-2
FIGURE B-2	Serial Port A and B Connector Pin Configuration	B-3
FIGURE B-3	TPE Connector Pin Configuration	B-6
FIGURE B-4	UltraSCSI Connector Pin Configuration	B-7
FIGURE B-5	Audio Connector Configuration	B-11
FIGURE B-6	Parallel Port Connector Pin Configuration	B-12
FIGURE B-7	MII Connector Pin Configuration	B-14
FIGURE B-8	UPA Graphics Card Connector Pin Configuration	B-16
FIGURE C-1	Ultra 60 System Unit Functional Block Diagram	C-3
FIGURE C-2	UPA Address and Data Buses Functional Block Diagram	C-5
FIGURE C-3	Memory System Functional Block Diagram	C-10
FIGURE C-4	Memory Module Functional Block Diagram	C-11
FIGURE C-5	DIMM Mapping	C-12
FIGURE C-6	Keyboard and Mouse, Diskette, and Parallel Port Functional Block Diagram	C-20
FIGURE C-7	Serial Port Functional Block Diagram	C-23
FIGURE C-8	MII Port Timing Model	C-27
FIGURE C-9	Audio Card Functional Block Diagram	C-29
FIGURE C-10	Configuration for the SCSI Bus	C-30
FIGURE C-11	SCSI Subassembly Functional Block Diagram	C-32
FIGURE C-12	System Unit Motherboard Functional Block Diagram	C-44
FIGURE C-13	Selected Jumper Settings	C-45
FIGURE C-14	Identifying Jumper Pins	C-45

Tables

TABLE 1-1	Supported I/O Devices	1-3
TABLE 1-2	System Unit Replaceable Components	1-6
TABLE 2-1	SunVTS Documentation	2-2
TABLE 3-1	Diag-Level Switch Settings	3-2
TABLE 3-2	Keyboard LED Patterns	3-21
TABLE 4-1	Internal Drives Identification	4-4
TABLE 4-2	Power Supply Connector J2901 Pin Description	4-6
TABLE 4-3	Power Supply Connector J2902 Pin Description	4-6
TABLE 4-4	Power Supply Connector J2903 Pin Description	4-7
TABLE 4-5	DIMM Physical Memory Address	4-8
TABLE 4-6	Selected OBP On-Board Diagnostic Tests	4-12
TABLE 10-1	DIMM Bank and Bank Quad	10-13
TABLE 10-2	Serial Port Jumper Settings	10-23
TABLE 11-1	System Unit Replaceable Components	11-3
TABLE A-1	System Unit Physical Specifications	A-2
TABLE A-2	Electrical Specifications	A-2
TABLE A-3	Environmental Requirements	A-3
TABLE B-1	Keyboard/Mouse Connector Pin Assignments	B-2
TABLE B-2	Serial Port A and B Connector Pin Assignments	B-3
TABLE B-3	TPE Connector Pin Assignments	B-6

TABLE B-4	UltraSCSI Connector Pin Assignments	B-7
TABLE B-5	Audio Connector Line Assignment	B-11
TABLE B-6	Parallel Port Connector Pin Assignments	B-12
TABLE B-7	MII Connector Pin Assignments	B-14
TABLE B-8	UPA Graphics Card Connector Pin Assignments	B-16
TABLE C-1	UPA Port Identification Assignments	C-4
TABLE C-2	DIMM Bank-to-U-Number Mapping	C-13
TABLE C-3	IL = 0, DIMM Bank-to-Physical Address Mapping	C-14
TABLE C-4	Diskette Drive Signals and Functions	C-17
TABLE C-5	Supported Hard Drives	C-18
TABLE C-6	Audio Card Features	C-28
TABLE C-7	Supported Target Devices	C-31
TABLE C-8	Power Supply Output Values	C-36
TABLE C-9	Power Supply Control Signal	C-37
TABLE C-10	300-MHz (3.3-ns) CPU Module(s) Power Estimate	C-40
TABLE C-11	PCI Card (5 Vdc) Power Estimate	C-40
TABLE C-12	PCI Card (3.3 Vdc) Power Estimate	C-41
TABLE C-13	Memory Subsystem Power Estimate	C-41
TABLE C-14	Mass Storage Device Power Estimates	C-41
TABLE C-15	Built-In Speaker Specifications	C-42
TABLE C-16	Serial Port Jumper Settings	C-46
TABLE C-17	Flash PROM Jumper Settings	C-47

Preface

The *Sun Ultra 60 Service Manual* provides detailed procedures that describe the removal and replacement of replaceable parts in the Ultra™ 60 computer (system unit). The service manual also includes information about the use and maintenance of the system unit. This book is written for technicians, system administrators, authorized service providers (ASPs), and advanced computer system end users who have experience troubleshooting and replacing hardware.

The revision of the *Sun Ultra 60 Service Manual* provided here is the latest revision of the document, and includes information that may be different from that contained in the service documentation originally shipped with the Sun Ultra 60 system.

How This Book Is Organized

This document is organized into chapters and appendices as listed in TABLE P-1. A glossary and an index is also included.

TABLE P-1 Document Organization

Chapter Number/Title	Content Description
Chapter 1, “Product Description”	Describes the major components of the system unit.
Chapter 2, “SunVTS Overview”	Describes the execution of individual tests for verifying hardware configuration and functionality.
Chapter 3, “Power-On Self-Test”	Describes the execution of POST and provides examples of POST output patterns.

TABLE P-1 Document Organization (*Continued*)

Chapter Number/Title	Content Description
Chapter 4, "Troubleshooting Procedures"	Provides troubleshooting advice and suggested corrective actions for hardware problems.
Chapter 5, "Safety and Tool Requirements"	Explains how to work safely when servicing the system unit.
Chapter 6, "Power On and Off"	Provides step-by-step procedures to power on and power off the system unit.
Chapter 7, "Internal Access"	Provides step-by-step procedures to remove the side access panel, attach the wrist strap, and replace the side access panel.
Chapter 8, "Major Subassemblies"	Provides step-by-step procedures to remove and replace major subassemblies.
Chapter 9, "Storage Devices"	Provides step-by-step procedures to remove and replace storage devices.
Chapter 10, "Motherboard and Component Replacement"	Provides step-by-step procedures to remove and replace the motherboard, and various components associated with motherboard operation.
Chapter 11, "Illustrated Parts List"	Lists replaceable parts for the system unit.
Appendix A, "Product Specifications"	Provides product specifications, system requirements about power and environment, system unit dimensions, weight, memory mapping, and peripheral component interconnect (PCI) card slot specifications.
Appendix B, "Signal Descriptions"	Provides signal descriptions.
Appendix C, "Functional Description"	Provides functional descriptions for the system unit.
Glossary	Provides a listing of acronyms, terms, and definitions.
Index	Provides a quick reference to specific topics.

UNIX Commands

This document may not contain information on basic UNIX[®] commands and procedures.

See one or more of the following for this information:

- *Solaris 2.x Handbook for SMCC Peripherals.*
- AnswerBook™ online documentation for the Solaris™ 2.x software environment.
- Other software documentation that you received with your system.

Typographic Conventions

TABLE P-2 Typographic Conventions

Typeface or Symbol	Meaning	Examples
AaBbCc123	The names of commands, files, and directories; on-screen computer output.	Edit your <code>.login</code> file. Use <code>ls -a</code> to list all files. % You have mail.
AaBbCc123	What you type, when contrasted with on-screen computer output.	% su Password:
<i>AaBbCc123</i>	Book titles, new words or terms, words to be emphasized. Command-line variable; replace with a real name or value.	Read Chapter 6 in the <i>User's Guide</i> . These are called <i>class</i> options. You <i>must</i> be root to do this. To delete a file, type <code>rm filename</code> .

Shell Prompts

TABLE P-3 Shell Prompts

Shell	Prompt
C shell	<i>machine_name%</i>

TABLE P-3 Shell Prompts

Shell	Prompt
C shell superuser	<i>machine_name</i> #
Bourne shell and Korn shell	\$
Bourne shell and Korn shell superuser	#

Related Documents

TABLE P-4 Related Documents

Application	Title	Part Number
Configuration	<i>Sun Ultra 60 System Reference Manual</i>	802-4147
Configuration	<i>Solaris Handbook for SMCC Peripherals</i>	802-7675
Diagnostics	<i>SunVTS 2.0 User's Guide</i>	802-5331
Diagnostics	<i>SunVTS 2.0 Test Reference Manual</i>	802-5330
Diagnostics	<i>SunVTS 2.0 Quick Reference Card</i>	802-5329
Installation	<i>14-Gbyte, 8-mm Tape Drive Installation Manual</i>	802-1849
Installation	<i>Creator Frame Buffer Installation Guide</i>	802-6682
Installation/user	<i>12-24 Gbyte 4-mm DDS-3 Tape Drive Installation and User's Guide</i>	802-7791
Installation	<i>5.25" Fast/Wide Differential SCSI Disk Drive Installation Manual</i>	802-1653
Installation/user	<i>SunCD 12 Installation and User's Guide</i>	805-0940
Specification	<i>Manual Eject Diskette Drive Specifications</i>	805-1133
Specification	<i>17-Inch Entry, 17-Inch Premium, and 20-Inch Premium Color Monitors Specifications</i>	802-6168
Specification	<i>4.2-Gbyte 7200-RPM Disk Drive Specifications</i>	802-7744
Specification	<i>9-Gbyte 7200-RPM Disk Drive Specifications</i>	802-7745
Specification	<i>SunCD 4 Drive Specifications</i>	802-4157

TABLE P-4 Related Documents (Continued)

Application	Title	Part Number
Specification	<i>8-mm Tape Drive Specifications</i>	802-5775
Specification	<i>4-mm, DDS-2 Tape Drive Specifications</i>	802-7790
Specification	<i>Manual Eject Diskette Drive Specifications</i>	805-1133
User	<i>24-Inch Premium (22.5-inch Viewable) Color Monitor Guide</i>	875-1799
User	<i>14-Gbyte, 8-mm Tape Drive User's Guide</i>	802-1850
User	<i>SBus Wide Intelligent UltraSCSI Differential Host Adapter Guide</i>	802-7748

Accessing Sun Documentation Online

A broad selection of Sun system documentation is located at:

<http://www.sun.com/products-n-solutions/hardware/docs>

A complete set of Solaris documentation and many other titles are located at:

<http://docs.sun.com>

Ordering Sun Documentation

Fatbrain.com, an Internet professional bookstore, stocks select product documentation from Sun Microsystems, Inc.

For a list of documents and how to order them, visit the Sun Documentation Center on Fatbrain.com at:

<http://www.fatbrain.com/documentation/sun>

Sun Welcomes Your Comments

Sun is interested in improving its documentation and welcomes your comments and suggestions. You can email your comments to Sun at:

`docfeedback@sun.com`

Please include the part number (805-1709-12) of your document in the subject line of your email.

Product Description

The Ultra 60 desktop workstation is a multiprocessor device that uses the family of UltraSPARC™ processors. It supports high-performance processing and high-performance graphics. FIGURE 1-1 illustrates the Ultra 60 desktop workstation. Enclosed within a minitower enclosure, the Ultra 60 desktop workstation provides the following:

- Power and cooling requirements for a high-performance processor and graphic function
- Modular internal design
- Improved disk, system, memory, and I/O performance and capacities
- Dual-head UltraSPARC port architecture (UPA) graphics capability
- High-performance peripheral component interconnect (PCI) I/O expansion with comparable options to existing SBus options

This chapter contains the following topics:

- I/O Devices—page 1-3
- System Unit Features—page 1-3
- System Unit Components—page 1-5

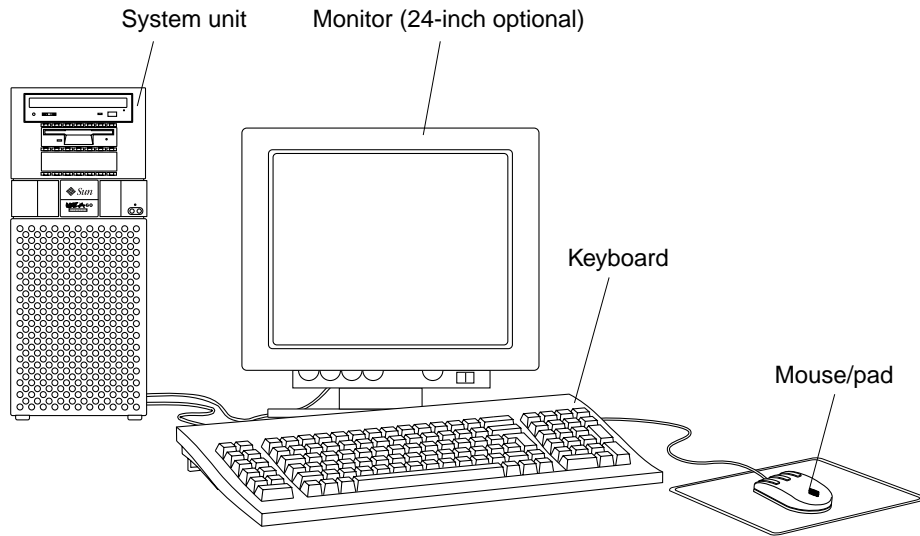

FIGURE 1-1 Ultra 60 Desktop Workstation

1.1 I/O Devices

The Ultra 60 desktop workstation uses the I/O devices listed in TABLE 1-1.

TABLE 1-1 Supported I/O Devices

I/O Devices	Description
20-inch (51-cm) color monitor	1152 x 900 resolution, 76- or 66-Hz refresh rate, 84 dots per inch (dpi)
	1280 x 1024 resolution, 76- or 66-Hz refresh rate, 93 dpi
	960 x 680 resolution, 112-Hz refresh rate, 70 dpi
24-inch (61-cm) color monitor	1920 x 1200 resolution, 70-Hz refresh rate, 103 dpi
	1600 x 1000 resolution, 76- or 66-Hz refresh rate, 86 dpi
	1400 x 900 resolution, 76-Hz refresh rate, 77 dpi
Microphone ¹	1280 x 800 resolution, 76-Hz refresh rate, 69 dpi
Keyboard	SunMicrophone™ II
Opto-mechanical mouse	Sun Type-5; AT 101 or UNIX layout available
	Optomechanical, 3-button

1. No longer ships with system, optional

1.2 System Unit Features

System unit components are housed in a tower configuration enclosure. Overall enclosure dimensions (width x depth x height) are 7.50 inches (19.0 cm) x 19.60 inches (49.8 cm) x 17.70 inches (45.0 cm). System unit electronics are contained on a single printed circuit board (motherboard). The motherboard contains the CPU modules, memory, system control application specific integrated circuits (ASICs), and I/O ASICs.

FIGURE 1-2 illustrates the system unit front view. FIGURE 1-3 illustrates the system unit rear view. System unit electronics and peripherals contain (or may be upgraded to contain) the following features:

- Tower enclosure with 350-watt power supply.
- Support for modular UltraSPARC II processor with up to a 4-megabyte (Mbyte) Ecache and system operating frequencies from 100 megahertz (MHz) to 400 MHz.
- 83.3-MHz to 120-MHz UPA coherent memory interconnect.
- Use of dual in-line memory modules (DIMMs). Each group of four DIMM slots accepts 16-, 32-, 64-, or 128-Mbyte DIMM modules. Populating with four identical capacity DIMMs enables the memory controller for optimal system performance. There are a total of 16 DIMM slots.
- Four PCI slots: three 33-MHz, 64-bit or 32-bit, 5 Vdc slots; one 66-MHz or 33-MHz, 64-bit or 32-bit, 3.3 Vdc slot
- Two UPA graphics slots.
- 10-/100-megabits per second Ethernet.
- 40-Mbytes per second UltraSCSI.
- Two DB25 serial ports (synchronous and asynchronous protocols).
- Centronics-compatible parallel port interface with extended capability port (ECP) support.
- Modular audio interface.

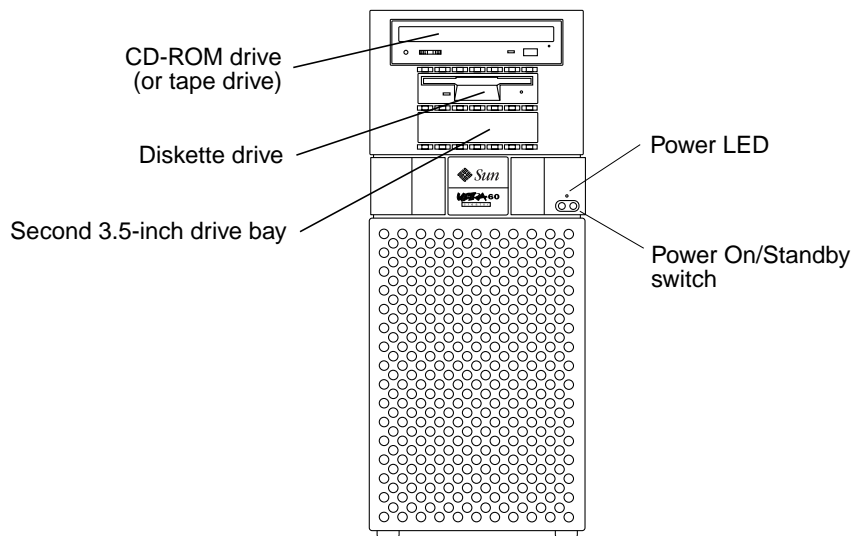

FIGURE 1-2 System Unit Front View

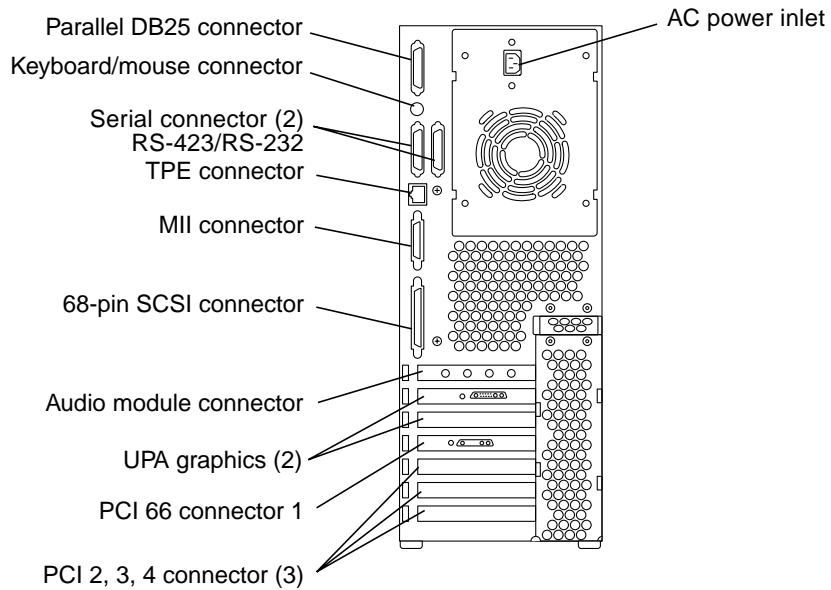

FIGURE 1-3 System Unit Rear View

1.3 System Unit Components

TABLE 1-2 lists the system unit components by part number. A brief description of each listed component is also provided.

Note – Removal and replacement of selected system unit components are also illustrated with photographs and audio/visual instructions on the *Sun Ultra 60 ShowMe How Multimedia Documentation*, part number 704-5886.

Note – Consult your authorized Sun sales representative or service provider to confirm a part number prior to ordering a replacement part.

TABLE 1-2 System Unit Replaceable Components

Component	Description
Motherboard	System board
Hard drive bay with SCSI	Mechanical hard drive housing
4.2-Gbyte SCSI assembly	Hard disk drive, 3.5-inch x 1.0-inch
9.1-Gbyte SCSI assembly	Hard disk drive, 3.5-inch x 1.6-inch
PCI fan assembly	PCI fan
Shroud assembly	Two-CPU shroud assembly
Fan assembly	CPU fan
CPU module	300-MHz, 2-Mbyte external cache
Graphics card	Vertical, single buffer UPA graphics card
Graphics card	Vertical, double buffer plus Z (DBZ) UPA graphics card
Power supply	Power supply, 350 watts
PCI card	Generic
Audio module	Audio applications, 16-bit audio, 8 kHz to 48 kHz
Speaker assembly	Speaker
Peripheral cable	Peripheral cable
Diskette drive cable	Diskette drive cable
Manual eject floppy	Diskette drive, 3.5-inch, MS-DOS compatible
EMI filler panel	CD-ROM drive filler panel
EMI filler panel	Diskette drive filler panel
16-Mbyte DIMM	60-ns, 16-Mbyte DIMM

TABLE 1-2 System Unit Replaceable Components *(Continued)*

Component	Description
32-Mbyte DIMM	60-ns, 32-Mbyte DIMM
64-Mbyte DIMM	60-ns, 64-Mbyte DIMM
128-Mbyte DIMM	60-ns, 128-Mbyte DIMM
NVRAM/TOD	Time of day, 48T59, with carrier
CD-ROM drive	12X-speed CD-ROM drive, 644-Mbyte SunCD™
4-mm tape drive	4-Gbyte/8-Gbyte, 4-mm tape drive, DDS-2
4-mm tape drive	12-Gbyte/24-Gbyte, 4-mm tape drive, DDS-3
8-mm tape drive	14-Gbyte, 8-mm tape drive
TPE cable (category 5)	Twisted-pair Ethernet cable
DC switch assembly	DC switch assembly

SunVTS Overview

This chapter contains an overview of the SunVTS™ diagnostic tool.

This chapter contains the following topics:

- SunVTS Description—page 2-1
- SunVTS Operation—page 2-2

2.1 SunVTS Description

The SunVTS software executes multiple diagnostic hardware tests from a single user interface. SunVTS verifies the configuration, functionality, and reliability of most hardware controllers and devices.

The SunVTS software can be used in both the Common Desktop Environment (CDE) and the OPEN LOOK graphical user interface (GUI) environments, or from a TTY interface.

Within the CDE and OPEN LOOK GUI environments, test parameters can be set quickly and easily by pointing and clicking a mouse button.

With a TTY interface, the SunVTS software is used from a terminal or modem attached to a serial port. Data is input through the keyboard, rather than with a mouse, and only one screen of information is displayed at a time.

2.2 SunVTS Operation

TABLE 2-1 lists the documentation for the SunVTS software. These documents are available on the *Solaris on Sun Hardware AnswerBook*, which is on the *SMCC Updates* for the Solaris release.

TABLE 2-1 SunVTS Documentation

Title	Part Number	Description
<i>SunVTS User's Guide</i>	802-7299	Describes the SunVTS environment; starting and controlling various user interfaces; feature descriptions
<i>SunVTS Test Reference Manual</i>	802-7300	Describes each SunVTS test; provides various test options and command line arguments
<i>SunVTS Quick Reference Card</i>	802-7301	Provides overview of vtsui interface features

Power-On Self-Test

This chapter describes how to initiate power-on self-test (POST) diagnostics. The examples given in this chapter are representative, details of actual test results may be different, depending on system configurations.

This chapter contains the following topics:

- POST Overview—page 3-2
- Pre-POST Preparation—page 3-2
- Initializing POST—page 3-5
- Maximum and Minimum Levels of POST—page 3-6
- POST Progress and Error Reporting—page 3-18
- Bypassing POST—page 3-21
- Additional Keyboard Control Commands—page 3-22
- System and Keyboard LEDs—page 3-22
- Initializing Motherboard POST—page 3-23

3.1 POST Overview

POST is useful in determining if a portion of the system unit has failed and should be replaced. POST detects approximately 95 percent of system unit faults and is located in the system board OpenBoot™ PROM (OBP). The setting of two NVRAM variables, the `diag-switch?` and the `diag-level` flag, determine if POST is executed. TABLE 3-1 lists the `diag-switch?` and `diag-level` flag settings for disabling POST (off), enabling POST maximum (max), or enabling POST minimum (min).

TABLE 3-1 Diag-Level Switch Settings

Diag-Level Setting	POST Initialization	Serial Port A I/O	Serial Port A Error Output	Diag-Switch? Setting
Off	No	N/A	N/A	N/A
Max	Yes (power-on)	Enabled	Enabled	True
Min	Yes (power-on)	Disabled	Enabled	True

3.2 Pre-POST Preparation

Pre-POST preparation includes:

- Setting up a tip connection to another workstation or terminal to view POST progress and error messages. See Section 3.2.1, “Setting Up a Tip Connection” on page 3-3.
- Verifying baud rates between a workstation and a monitor or a workstation and a terminal. See Section 3.2.2, “Verifying the Baud Rate” on page 3-4.

If a terminal or a monitor is not connected to serial port A (default port) of a workstation or server to be tested, the keyboard LEDs are used to determine error conditions. See Section 3.7, “System and Keyboard LEDs” on page 3-22

3.2.1 Setting Up a Tip Connection

A tip connection enables a remote shell window to be used as a terminal to display test data of a system being tested. Serial port A or serial port B of a tested system unit is used to establish the tip connection between the system unit being tested and another Sun workstation monitor or TTY-type terminal. The tip connection is used in a SunOS™ window and provides features to help with the OBP.

To set up a tip connection:

1. See FIGURE 3-1. Connect serial port A of the system being tested to serial port B of another Sun workstation using a serial null modem cable (connect cable pins 2-3, 3-2, 7-20, and 20-7).

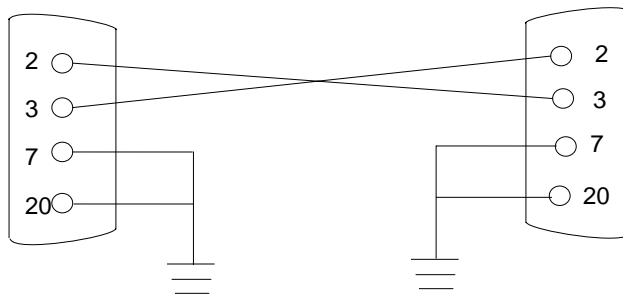

FIGURE 3-1 Setting Up a TIP Connection

2. At the other Sun workstation, check the `/etc/remote` file by changing to the `/etc` directory and then editing the `remote` file:

```
hardware:/ dv=/dev/term/b:br#9600:e1=^C^S^Q^U^D:ie=%$:oe=^D:
```

Note – The example shows connection to serial port B.

3. To use serial port A:
 - a. Copy and paste the serial port B `remote` file.
 - b. Modify the serial port B `remote` file as follows:

```
hardware:\ dv=/dev/term/a:a:br#9600:e1=^C^S^Q^U^D:ie=%$:oe=^D:
```

4. In a shell window on the Sun workstation, type `tip hardware`.

```
hostname% tip hardware
connected
```

Note – The shell window is now a tip window directed to the serial port of the system unit being tested. When power is applied to the system unit being tested, POST messages will be displayed in this window.

5. When POST is completed, disconnect the tip window as follows:

- a. Open a shell window.
- b. Type `ps -a` to view the active tip line and process ID (PID) number.
- c. Type the following to kill the tip hardware process.

```
% kill -9 PID#
```

3.2.2 Verifying the Baud Rate

To verify the baud rate between the system unit being tested and a terminal or another Sun workstation monitor:

1. Open a Shell window.
2. Type `eeeprom`.
3. Verify the following serial port default settings as follows:

```
ttyb-mode = 9600,8,n,1
ttya-mode = 9600,8,n,1
```

Note – Ensure that the settings are consistent with TTY-type terminal or workstation monitor settings.

3.3 Initializing POST

POST is initialized in two ways:

- By setting the `diag-switch?` to `true` and the `diag-level` to `max` or `min`, followed by power cycling the system unit
- By simultaneously pressing the keyboard Stop and D keys while power is applied to the system unit

To set the `diag-switch?` to `true` and power cycle the system unit:

1. At the system prompt, type:

```
ok setenv diag-switch? true
```

2. At the keyboard, power cycle the system unit by simultaneously pressing the Shift key and the power-on key (FIGURE 3-2). After a few seconds, press the power-on key again.

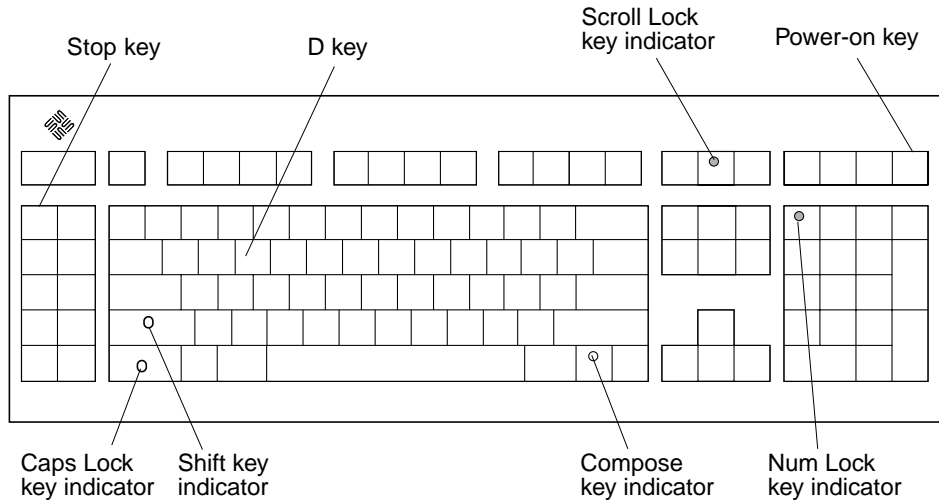

FIGURE 3-2 Sun Type-5 Keyboard

3. Verify the following:

- a. The display prompt is no longer displayed.
- b. The monitor power-on indicator flashes on and off.
- c. The keyboard Caps Lock key indicator flashes on and off.

4. When the POST is complete, type the following at the system prompt:

```
ok setenv diag-switch? false
```

3.4 Maximum and Minimum Levels of POST

Two levels of POST are available: maximum (max) level and minimum (min) level. The system initiates the selected level of POST based upon the setting of `diag-level`, a NVRAM variable.

The default setting for `diag-level` is `max`. An example of a `max` level POST output on serial port A is provided in Section 3.4.1, “diag-level Variable Set to max” on page 3-7. An example of a `min` level POST output on serial port A is provided in Section 3.4.2, “diag-level Variable Set to min” on page 3-14.

To set the `diag-level` variable to `min`, type:

```
ok setenv diag-level min
```

To return to the default setting:

```
ok setenv diag-level max
```

3.4.1 diag-level Variable Set to max

When the `diag-level` variable is set to `max`, POST enables an extended set of diagnostic-level tests. This mode requires approximately 2 minutes and 15 seconds to complete (with 128 Mbytes of DIMM installed). CODE EXAMPLE 3-1 identifies a typical serial port A POST output with the `diag-level` variable set to `max`

CODE EXAMPLE 3-1 `diag-level` Variable Set to max

```
Executing Power On SelfTest

0>
0>@(#) Sun Ultra 60(UltraSPARC-II 2-way) UPA/PCI POST x.x.x
xx/xx/xxxx xx:xx PM
0>INFO: Processor 0 is master.
0>
0> <00> Init System BSS
0> <00> NVRAM Battery Detect Test
0> <00> NVRAM Scratch Addr Test
0> <00> DMMU TLB Tag Access Test
0> <00> DMMU TLB RAM Access Test
0> <00> IMMU TLB Tag Access Test
0> <00> IMMU TLB RAM Access Test
0> <00> Probe Ecache
0>INFO:CPU 296 MHz: 2048KB Ecache
0> <00> Ecache RAM Addr Test
0> <00> Ecache Tag Addr Test
0> <00> Ecache Tag Test
0> <00> Invalidate Ecache Tags
0>INFO: Processor 2 - UltraSPARC-II.
0> <00> Init SC Regs
0> <00> SC Address Reg Test
0> <00> SC Reg Index Test
0> <00> SC Regs Test
0> <00> SC Dtag RAM Addr Test
0> <00> SC Cache Size Init
0> <00> SC Dtag RAM Data Test
0> <00> SC Dtag Init
0> <00> Probe Memory
0>INFO:128MB Bank 0
0>INFO: 0MB Bank 1
0>INFO: 0MB Bank 2
0>INFO: 0MB Bank 3
0> <00> Malloc Post Memory
0> <00> Init Post Memory
0> <00> Post Memory Addr Test
0> <00> Map PROM/STACK/NVRAM in DMMU
0> <00>Memory Stack Test
```

CODE EXAMPLE 3-1 diag-level Variable Set to max (Continued)

```
2> <00> DMMU TLB Tag Access Test
2> <00> DMMU TLB RAM Access Test
2> <00> IMMU TLB Tag Access Test
2> <00> IMMU TLB RAM Access Test
2> <00> Probe Ecache
2>INFO:CPU 296 MHz: 2048KB Ecache
2> <00> Ecache RAM Addr Test
2> <00> Ecache Tag Addr Test
2> <00> Ecache Tag Test
2> <00> Invalidate Ecache Tags
2> <00> Map PROM/STACK/NVRAM in DMMU
2> <00> Update Slave Stack/Frame Ptrs
0> <00> DMMU Hit/Miss Test
0> <00> IMMU Hit/Miss Test
0> <00> DMMU Little Endian Test
0> <00> IU ASI Access Test
0> <00> FPU ASI Access Test
2> <00> DMMU Hit/Miss Test
2> <00> IMMU Hit/Miss Test
2> <00> DMMU Little Endian Test
2> <00> IU ASI Access Test
2> <00> FPU ASI Access Test
2> <00> Dcache RAM Test
2> <00> Dcache Tag Test
2> <00> Icache RAM Test
2> <00> Icache Tag Test
2> <00> Icache Next Test
2> <00> Icache Predecode Test
0> <1f> Init Psycho
0> <1f> PIO Read Error, Master Abort Test
0> <1f> PIO Read Error, Target Abort Test
0> <1f> PIO Write Error, Master Abort Test
0> <1f> PIO Write Error, Target Abort Test
0> <1f> Timer Increment Test
0> <1f> Consistent DMA UE ECC Rd Err Lpbk Test
0> <1f> Pass-Thru DMA UE ECC Rd Err Lpbk Test
0> <00> Copy Post to Memory
0> <00> Ecache Thrash Test
0> <00> Init Memory
0> <00> Memory Addr w/ Ecache Test
0>INFO:128MB Bank 0
0>INFO: 0MB Bank 1
0>INFO: 0MB Bank 2
0>INFO: 0MB Bank 3
0> <00> Block Memory Addr Test
0>INFO:128MB Bank 0
0>INFO: 0MB Bank 1
```

CODE EXAMPLE 3-1 diag-level Variable Set to max (Continued)

```
0>INFO:  OMB Bank 2
0>INFO:  OMB Bank 3
0> <00> ECC Memory Addr Test
0>INFO:128MB Bank 0
0>INFO:  OMB Bank 1
0>INFO:  OMB Bank 2
0>INFO:  OMB Bank 3
0> <00> Memory Status Test
0>INFO:128MB Bank 0
0>INFO:  OMB Bank 1
0>INFO:  OMB Bank 2
0>INFO:  OMB Bank 3
0> <00> V9 Instruction Test
0> <00> CPU Tick and Tick Compare Reg Test
0> <00> CPU Soft Trap Test
0> <00> CPU Softint Reg and Int Test
2> <00> V9 Instruction Test
2> <00> CPU Tick and Tick Compare Reg Test
0> <1f> Init Psycho
0> <1f> Psycho Cntl and UPA Reg Test
0> <1f> Psycho DMA Scoreboard Reg Test
0> <1f> Psycho Perf Cntl Reg Test
0> <1f> PIO Decoder and BCT Test
0> <1f> PCI Byte Enable Test
0> <1f> Counter/Timer Limit Regs Test
0> <1f> Timer Reload Test
0> <1f> Timer Periodic Test
0> <1f> Mondo Int Map (short) Reg Test
0> <1f> Mondo Int Set/Clr Reg Test
0> <1f> Psycho IOMMU Regs Test
0> <1f> Psycho IOMMU RAM Address Test
0> <1f> Psycho IOMMU CAM Address Test
0> <1f> IOMMU TLB Compare Test
0> <1f> IOMMU TLB Flush Test
0> <1f> Stream Buff A Control Reg Test
0> <1f> Psycho ScacheA Page Tag Addr Test
0> <1f> Psycho ScacheA Line Tag Addr Test
0> <1f> Psycho ScacheA RAM Addr Test
0> <1f> Psycho ScacheA Error Status NTA Test
0> <1f> Psycho ScacheB Page Tag Addr Test
0> <1f> Psycho ScacheB Line Tag Addr Test
0> <1f> Psycho ScacheB RAM Addr Test
0> <1f> Psycho ScacheB Error Status NTA Test
0> <1f> PBMA PCI Config Space Regs Test
0> <1f> PBMA Control/Status Reg Test
0> <1f> PBMA Diag Reg Test
0> <1f> PBMB PCI Config Space Regs Test
```

CODE EXAMPLE 3-1 diag-level Variable Set to max (Continued)

```
0> <1f> PBMB Control/Status Reg Test
0> <1f> PBMB Diag Reg Test
0> <00> FPU Regs Test
0> <00> FPU Move Regs Test
0> <00> FPU State Reg Test
0> <00> FPU Functional Test
0> <00> FPU Trap Test
0> <00> DMMU Primary Context Reg Test
0> <00> DMMU Secondary Context Reg Test
0> <00> DMMU TSB Reg Test
0> <00> DMMU Tag Access Reg Test
0> <00> DMMU VA Watchpoint Reg Test
0> <00> DMMU PA Watchpoint Reg Test
0> <00> IMMU TSB Reg Test
0> <00> IMMU Tag Access Reg Test
0> <00> DMMU TLB Tag Access Test
0> <00> DMMU TLB RAM Access Test
0> <00> Dcache RAM Test
0> <00> Dcache Tag Test
0> <00> Icache RAM Test
0> <00> Icache Tag Test
0> <00> Icache Next Test
0> <00> Icache Predecode Test
2> <00> FPU Regs Test
2> <00> FPU Move Regs Test
2> <00> FPU State Reg Test
2> <00> FPU Functional Test
2> <00> FPU Trap Test
2> <00> DMMU Primary Context Reg Test
2> <00> DMMU Secondary Context Reg Test
2> <00> DMMU TSB Reg Test
2> <00> DMMU Tag Access Reg Test
2> <00> DMMU VA Watchpoint Reg Test
2> <00> DMMU PA Watchpoint Reg Test
2> <00> IMMU TSB Reg Test
2> <00> IMMU Tag Access Reg Test
2> <00> DMMU TLB Tag Access Test
2> <00> DMMU TLB RAM Access Test
0> <00> CPU Addr Align Trap Test
0> <00> DMMU Access Priv Page Test
0> <00> DMMU Write Protected Page Test
0> <1f> Init Psycho
0> <1f> Pri CE ECC Error Test
0> <1f> Pri UE ECC Error Test
0> <1f> Pri 2 bit w/ bit hole UE ECC Err Test
0> <1f> Pri 3 bit UE ECC Err Test
0> <1f> Streaming DMA UE ECC Rd Err Ebus Test
```

CODE EXAMPLE 3-1 diag-level Variable Set to max (Continued)

```
0> <lf> Streaming DMA CE ECC Rd Err Ebus Test
0> <lf> Streaming DMA CE ECC Rd Err Lpbk Test
0> <lf> Consistent DMA UE ECC Rd Error Ebus Test
0> <lf> Consistent DMA UE ECC R/M/W Err Ebus Test
0> <lf> Consistent DMA UE ECC R/M/W Err Lpbk Test
0> <lf> Consistent DMA CE ECC Rd Err Ebus Test
0> <lf> Consistent DMA CE ECC Rd Err Lpbk Test
0> <lf> Consistent DMA CE ECC R/M/W Err Ebus Test
0> <lf> Consistent DMA CE ECC R/M/W Err Lpbk Test
0> <lf> Consistent DMA Wr Data Parity Err Lpbk Test
0> <lf> Pass-Thru DMA UE ECC Rd Err Ebus Test
0> <lf> Pass-Thru DMA UE ECC R/M/W Err Ebus Test
0> <lf> Pass-Thru DMA UE ECC R/M/W Err Lpbk Test
0> <lf> Pass-Thru DMA CE ECC Rd Err Ebus Test
0> <lf> Pass-Thru DMA CE ECC Rd Err Lpbk Test
0> <lf> Pass-Thru DMA CE ECC R/M/W Err Ebus Test
0> <lf> Pass-Thru DMA CE ECC R/M/W Err Lpbk Test
0> <lf> Pass-Thru DMA Write Data Parity Err, Lpbk Test
0> <lf> Init Psycho
0> <lf> Mondo Generate Interrupt Test
0> <lf> Timer Interrupt Test
0> <lf> Timer Interrupt w/ periodic Test
0> <lf> Psycho Stream Buff A Flush Sync Test
0> <lf> Psycho Stream Buff B Flush Sync Test
0> <lf> Psycho Stream Buff A Flush Invalidate Test
0> <lf> Psycho Stream Buff B Flush Invalidate Test
0> <lf> Psycho Merge Buffer w/ Scache A Test
0> <lf> Psycho Merge Buffer w/ Scache B Test
0> <lf> Consist DMA Rd, IOMMU miss Ebus Test
0> <lf> Consist DMA Rd, IOMMU miss Lpbk Test
0> <lf> Consist DMA Rd, IOMMU hit Ebus Test
0> <lf> Consist DMA Rd, IOMMU hit Lpbk Test
0> <lf> Consist DMA Wr, IOMMU miss Ebus Test
0> <lf> Consist DMA Wr, IOMMU miss Lpbk Test
0> <lf> Consist DMA Wr, IOMMU hit Ebus Test
0> <lf> Consist DMA Wr, IOMMU hit Lpbk Test
0> <lf> Stream DMA Rd, IOMMU miss, Scache Miss Ebus Test
0> <lf> Stream DMA Rd, IOMMU miss, Scache Miss Lpbk Test
0> <lf> Stream DMA Rd, IOMMU hit, Scache Miss Ebus Test
0> <lf> Stream DMA Rd, IOMMU hit, Scache Miss Lpbk Test
0> <lf> Stream DMA Rd, IOMMU Miss, Scache(prev rd) Hit Ebus Test
0> <lf> Stream DMA Rd, IOMMU Miss, Scache Hit (prev rd) Lpbk Test
0> <lf> Stream DMA Rd, IOMMU Hit, Scache Hit Ebus Test
0> <lf> Stream DMA Rd, IOMMU Hit, Scache Hit (prev rd) Lpbk Test
0> <lf> Stream DMA Rd, IOMMU Miss, Scache Hit(prev wr) Ebus Test
0> <lf> Stream DMA Rd, IOMMU Miss, Scache Hit (prev wr) Lpbk Test
0> <lf> Stream DMA Rd, IOMMU Hit, Scache Hit(prev wr) Ebus Test
```

CODE EXAMPLE 3-1 diag-level Variable Set to max (Continued)

```
0> <1f> Stream DMA Rd, IOMMU Hit, Scache Hit (prev wr) Lpbk Test
0> <1f> Stream DMA Wr, IOMMU miss, Scache Miss Ebus Test
0> <1f> Stream DMA Wr, IOMMU miss, Scache Miss Lpbk Test
0> <1f> Stream DMA Wr, IOMMU hit, Scache Miss Ebus Test
0> <1f> Stream DMA Wr, IOMMU hit, Scache Miss Lpbk Test
0> <1f> Stream DMA Wr, IOMMU Miss, Scache(prev rd) Hit Ebus Test
0> <1f> Stream DMA Wr, IOMMU Miss, Scache(prev rd) Hit Lpbk Test
0> <1f> Stream DMA Wr, IOMMU Hit, Scache(prev rd) Hit Ebus Test
0> <1f> Stream DMA Wr, IOMMU Hit, Scache(prev rd) Hit Lpbk Test
0> <1f> Stream DMA Wr, IOMMU Miss, Scache(prev wr) Hit Ebus Test
0> <1f> Stream DMA Wr, IOMMU Miss, Scache(prev wr) Hit Lpbk Test
0> <1f> Stream DMA Wr, IOMMU Hit, Scache(prev wr) Hit Ebus Test
0> <1f> Stream DMA Wr, IOMMU Hit, Scache(prev wr) Hit Lpbk Test
0> <1f> Pass-Thru DMA Rd, Ebus device Test
0> <1f> Pass-Thru DMA Rd, Loopback Mode Test
0> <1f> Pass-Thru DMA Wr, Ebus device Test
0> <1f> Pass-Thru DMA Wr, Loopback Mode Test
0> <1f> Consist DMA Rd, IOMMU LRU Lock Ebus Test
0> <1f> Consist DMA Rd, IOMMU LRU Lock Lpbk Test
0> <1f> Stream DMA Rd, IOMMU LRU Lock, Scache LRU Lock Ebus Test
0> <1f> Stream DMA Rd, IOMMU LRU Lock, Scache LRU Lock Lpbk Test
0> <1f> Stream DMA Rd, IOMMU miss, Scache LRU Lock Ebus Test
0> <1f> Stream DMA Rd, IOMMU Miss, Scache LRU Lock Lpbk Test
0> <1f> Stream DMA Rd, IOMMU Hit, Scache LRU Lock Ebus Test
0> <1f> Stream DMA Rd, IOMMU Hit, Scache LRU Lock Lpbk Test
0> <1f> Stream DMA Rd, IOMMU LRU Lock, Scache Miss Ebus Test
0> <1f> Stream DMA Rd, IOMMU LRU Lock, Scache Miss Lpbk Test
0> <1f> Consist DMA Wr, IOMMU LRU Locked Ebus Test
0> <1f> Consist DMA Wr, IOMMU LRU Lock Lpbk Test
0> <1f> Stream DMA Wr, IOMMU LRU Lock, Scache LRU Lock Ebus Test
0> <1f> Stream DMA Wr, IOMMU LRU Lock, Scache LRU Lock Lpbk Test
0> <1f> Stream DMA Wr, IOMMU Miss, Scache LRU Lock Ebus Test
0> <1f> Stream DMA Wr, IOMMU Miss, Scache LRU Lock Lpbk Test
0> <1f> Stream DMA Wr, IOMMU Hit, Scache LRU Lock Ebus Test
0> <1f> Stream DMA Wr, IOMMU Hit, Scache LRU Lock Lpbk Test
0> <1f> Stream DMA Wr, IOMMU LRU Lock, Scache Miss Ebus Test
0> <1f> Stream DMA Wr, IOMMU LRU Lock, Scache Miss Lpbk Test
0> <1f> Stream DMA Wr, IOMMU LRU Lock, Scache(prev rd) Hit Ebus
Test
0> <1f> Stream DMA Wr, IOMMU LRU Lock, Scache(prev rd) Hit Lpbk
Test
0> <00> Init Memory
0>INFO:128MB Bank 0
0>INFO: 0MB Bank 1
0>INFO: 0MB Bank 2
0>INFO: 0MB Bank 3
0> <00> Memory w/ Ecache Test
```

CODE EXAMPLE 3-1 diag-level Variable Set to max (Continued)

```
0>INFO:128MB Bank 0
0>INFO:  OMB Bank 1
0>INFO:  OMB Bank 2
0>INFO:  OMB Bank 3
0> <00> Block Memory Test
0>INFO:128MB Bank 0
0>INFO:  OMB Bank 1
0>INFO:  OMB Bank 2
0>INFO:  OMB Bank 3
0> <00> ECC Blk Memory Test
0>INFO:128MB Bank 0
0>INFO:  OMB Bank 1
0>INFO:  OMB Bank 2
0>INFO:  OMB Bank 3
0> <00> UltraSPARC-2 Prefetch Instructions Test
0> <00>Test 0: prefetch_mr
0> <00>Test 1: prefetch to non-cacheable page
0> <00>Test 2: prefetch to page with dmmu miss
0> <00>Test 3: prefetch miss does not check alignment
0> <00>Test 4: prefetcha with asi 0x4c is noped
0> <00>Test 5: prefetcha with asi 0x54 is noped
0> <00>Test 6: prefetcha with asi 0x6e is noped
0> <00>Test 7: prefetcha with asi 0x76 is noped
0> <00>Test 8: prefetch with fcn 5
0> <00>Test 9: prefetch with fcn 2
0> <00>Test 10: prefetch with fcn 12
0> <00>Test 11: prefetch with fcn 16 is noped
0> <00>Test 12: prefetch with fcn 29 is noped
0> <00>Test 13: prefetcha with asi 0x15 is noped
0> <00>Test 14: prefetch with fcn 3
0> <00>Test 15: prefetcha14 with fcn 2
0> <00>Test 16: prefetcha80_mr
0> <00>Test 17: prefetcha81_lr
0> <00>Test 18: prefetcha10_mw
0> <00>Test 19: prefetcha80_17 is noped
0> <00>Test 20: prefetcha10_6: illegal instruction trap
0> <00>Test 21: prefetcha11_1w
0> <00>Test 22: prefetcha81_31
0> <00>Test 23: prefetcha11_15: illegal instruction trap
2> <00> UltraSPARC-2 Prefetch Instructions Test
2> <00>Test 0: prefetch_mr
2> <00>Test 1: prefetch to non-cacheable page
2> <00>Test 2: prefetch to page with dmmu miss
2> <00>Test 3: prefetch miss does not check alignment
2> <00>Test 4: prefetcha with asi 0x4c is noped
2> <00>Test 5: prefetcha with asi 0x54 is noped
2> <00>Test 6: prefetcha with asi 0x6e is noped
```

CODE EXAMPLE 3-1 diag-level Variable Set to max (Continued)

```
2> <00>Test 7: prefetcha with asi 0x76 is noped
2> <00>Test 8: prefetch with fcn 5
2> <00>Test 9: prefetch with fcn 2
2> <00>Test 10: prefetch with fcn 12
2> <00>Test 11: prefetch with fcn 16 is noped
2> <00>Test 12: prefetch with fcn 29 is noped
2> <00>Test 13: prefetcha with asi 0x15 is noped
2> <00>Test 14: prefetch with fcn 3
2> <00>Test 15: prefetcha14 with fcn 2
2> <00>Test 16: prefetcha80_mr
2> <00>Test 17: prefetcha81_lr
2> <00>Test 18: prefetcha10_mw
2> <00>Test 19: prefetcha80_17 is noped
2> <00>Test 20: prefetcha10_6: illegal instruction trap
2> <00>Test 21: prefetcha11_lw
2> <00>Test 22: prefetcha81_31
2> <00>Test 23: prefetcha11_15: illegal instruction trap
0>STATUS =PASSED
```

Power On Selftest Completed

3.4.2 diag-level Variable Set to min

When the diag-level variable is set to min, POST enables an abbreviated set of diagnostic-level tests. This mode requires approximately 1 minute and 30 seconds to complete (with 128 Mbytes of DIMM installed). CODE EXAMPLE 3-2 identifies a serial port A POST output with the diag-level NVRAM variable set to min.

CODE EXAMPLE 3-2 diag-level Variable Set to min

```
Executing Power On SelfTest

0>
0>@(#) Sun Ultra 60(UltraSPARC-II 2-way) UPA/PCI POST x.x.x
xx/xx/xxxx xx:xx PM
0>INFO: Processor 0 is master.
0>
0> <00> Init System BSS
0> <00> NVRAM Battery Detect Test
0> <00> NVRAM Scratch Addr Test
0> <00> DMMU TLB Tag Access Test
0> <00> DMMU TLB RAM Access Test
0> <00> IMMU TLB Tag Access Test
```

CODE EXAMPLE 3-2 diag-level Variable Set to min (Continued)

```
0> <00> IMMU TLB RAM Access Test
0> <00> Probe Ecache
0>INFO:CPU 296 MHz: 2048KB Ecache
0> <00> Ecache RAM Addr Test
0> <00> Ecache Tag Addr Test
0> <00> Ecache Tag Test
0> <00> Invalidate Ecache Tags
0>INFO: Processor 2 - UltraSPARC-II.
0> <00> Init SC Regs
0> <00> SC Address Reg Test
0> <00> SC Reg Index Test
0> <00> SC Regs Test
0> <00> SC Dtag RAM Addr Test
0> <00> SC Cache Size Init
0> <00> SC Dtag RAM Data Test
0> <00> SC Dtag Init
0> <00> Probe Memory
0>INFO:128MB Bank 0
0>INFO: 0MB Bank 1
0>INFO: 0MB Bank 2
0>INFO: 0MB Bank 3
0> <00> Malloc Post Memory
0> <00> Init Post Memory
0> <00> Post Memory Addr Test
0> <00> Map PROM/STACK/NVRAM in DMMU
0> <00>Memory Stack Test
2> <00> DMMU TLB Tag Access Test
2> <00> DMMU TLB RAM Access Test
2> <00> IMMU TLB Tag Access Test
2> <00> IMMU TLB RAM Access Test
2> <00> Probe Ecache
2>INFO:CPU 296 MHz: 2048KB Ecache
2> <00> Ecache RAM Addr Test
2> <00> Ecache Tag Addr Test
2> <00> Ecache Tag Test
2> <00> Invalidate Ecache Tags
2> <00> Map PROM/STACK/NVRAM in DMMU
2> <00> Update Slave Stack/Frame Ptrs
0> <00> DMMU Hit/Miss Test
0> <00> IMMU Hit/Miss Test
0> <00> DMMU Little Endian Test
0> <00> IU ASI Access Test
0> <00> FPU ASI Access Test
2> <00> DMMU Hit/Miss Test
2> <00> IMMU Hit/Miss Test
2> <00> DMMU Little Endian Test
2> <00> IU ASI Access Test
```

CODE EXAMPLE 3-2 diag-level Variable Set to min (Continued)

```
2> <00> FPU ASI Access Test
2> <00> Dcache RAM Test
2> <00> Dcache Tag Test
2> <00> Icache RAM Test
2> <00> Icache Tag Test
2> <00> Icache Next Test
2> <00> Icache Predecode Test
0> <1f> Init Psycho
0> <1f> PIO Read Error, Master Abort Test
0> <1f> PIO Read Error, Target Abort Test
0> <1f> PIO Write Error, Master Abort Test
0> <1f> PIO Write Error, Target Abort Test
0> <1f> Timer Increment Test
0> <1f> Consistent DMA UE ECC Rd Err Lpbk Test
0> <1f> Pass-Thru DMA UE ECC Rd Err Lpbk Test
0> <00> Copy Post to Memory
0> <00> Ecache Thrash Test
0> <00> Init Memory
0> <00> Memory Addr w/ Ecache Test
0>INFO:128MB Bank 0
0>INFO: 0MB Bank 1
0>INFO: 0MB Bank 2
0>INFO: 0MB Bank 3
0> <00> Block Memory Addr Test
0>INFO:128MB Bank 0
0>INFO: 0MB Bank 1
0>INFO: 0MB Bank 2
0>INFO: 0MB Bank 3
0> <00> ECC Memory Addr Test
0>INFO:128MB Bank 0
0>INFO: 0MB Bank 1
0>INFO: 0MB Bank 2
0>INFO: 0MB Bank 3
0> <00> Memory Status Test
0>INFO:128MB Bank 0
0>INFO: 0MB Bank 1
0>INFO: 0MB Bank 2
0>INFO: 0MB Bank 3
0> <00> V9 Instruction Test
0> <00> CPU Tick and Tick Compare Reg Test
0> <00> CPU Soft Trap Test
0> <00> CPU Softint Reg and Int Test
2> <00> V9 Instruction Test
2> <00> CPU Tick and Tick Compare Reg Test
0> <1f> Init Psycho
0> <1f> Psycho Cntl and UPA Reg Test
0> <1f> Psycho DMA Scoreboard Reg Test
```

CODE EXAMPLE 3-2 diag-level Variable Set to min (Continued)

```
0> <1f> Psycho Perf Cntl Reg Test
0> <1f> PIO Decoder and BCT Test
0> <1f> PCI Byte Enable Test
0> <1f> Counter/Timer Limit Regs Test
0> <1f> Timer Reload Test
0> <1f> Timer Periodic Test
0> <1f> Mondo Int Map (short) Reg Test
0> <1f> Mondo Int Set/Clr Reg Test
0> <1f> Psycho IOMMU Regs Test
0> <1f> Psycho IOMMU RAM Address Test
0> <1f> Psycho IOMMU CAM Address Test
0> <1f> IOMMU TLB Compare Test
0> <1f> IOMMU TLB Flush Test
0> <1f> Stream Buff A Control Reg Test
0> <1f> Psycho ScacheA Page Tag Addr Test
0> <1f> Psycho ScacheA Line Tag Addr Test
0> <1f> Psycho ScacheA RAM Addr Test
0> <1f> Psycho ScacheA Error Status NTA Test
0> <1f> Psycho ScacheB Page Tag Addr Test
0> <1f> Psycho ScacheB Line Tag Addr Test
0> <1f> Psycho ScacheB RAM Addr Test
0> <1f> Psycho ScacheB Error Status NTA Test
0> <1f> PBMA PCI Config Space Regs Test
0> <1f> PBMA Control/Status Reg Test
0> <1f> PBMA Diag Reg Test
0> <1f> PBMB PCI Config Space Regs Test
0> <1f> PBMB Control/Status Reg Test
0> <1f> PBMB Diag Reg Test
0> <00> UltraSPARC-2 Prefetch Instructions Test
0> <00>Test 0: prefetch_mr
0> <00>Test 1: prefetch to non-cacheable page
0> <00>Test 2: prefetch to page with dmmu miss
0> <00>Test 3: prefetch miss does not check alignment
0> <00>Test 4: prefetcha with asi 0x4c is noped
0> <00>Test 5: prefetcha with asi 0x54 is noped
0> <00>Test 6: prefetcha with asi 0x6e is noped
0> <00>Test 7: prefetcha with asi 0x76 is noped
0> <00>Test 8: prefetch with fcn 5
0> <00>Test 9: prefetch with fcn 2
0> <00>Test 10: prefetch with fcn 12
0> <00>Test 11: prefetch with fcn 16 is noped
0> <00>Test 12: prefetch with fcn 29 is noped
0> <00>Test 13: prefetcha with asi 0x15 is noped
0> <00>Test 14: prefetch with fcn 3
0> <00>Test 15: prefetcha14 with fcn 2
0> <00>Test 16: prefetcha80_mr
0> <00>Test 17: prefetcha81_lr
```

CODE EXAMPLE 3-2 diag-level Variable Set to min (Continued)

```
0> <00>Test 18: prefetcha10_mw
0> <00>Test 19: prefetcha80_17 is noped
0> <00>Test 20: prefetcha10_6: illegal instruction trap
0> <00>Test 21: prefetcha11_lw
0> <00>Test 22: prefetcha81_31
0> <00>Test 23: prefetcha11_15: illegal instruction trap
2> <00> UltraSPARC-2 Prefetch Instructions Test
2> <00>Test 0: prefetch_mr
2> <00>Test 1: prefetch to non-cacheable page
2> <00>Test 2: prefetch to page with dmmu miss
2> <00>Test 3: prefetch miss does not check alignment
2> <00>Test 4: prefetcha with asi 0x4c is noped
2> <00>Test 5: prefetcha with asi 0x54 is noped
2> <00>Test 6: prefetcha with asi 0x6e is noped
2> <00>Test 7: prefetcha with asi 0x76 is noped
2> <00>Test 8: prefetch with fcn 5
2> <00>Test 9: prefetch with fcn 2
2> <00>Test 10: prefetch with fcn 12
2> <00>Test 11: prefetch with fcn 16 is noped
2> <00>Test 12: prefetch with fcn 29 is noped
2> <00>Test 13: prefetcha with asi 0x15 is noped
2> <00>Test 14: prefetch with fcn 3
2> <00>Test 15: prefetcha14 with fcn 2
2> <00>Test 16: prefetcha80_mr
2> <00>Test 17: prefetcha81_lr
2> <00>Test 18: prefetcha10_mw
2> <00>Test 19: prefetcha80_17 is noped
2> <00>Test 20: prefetcha10_6: illegal instruction trap
2> <00>Test 21: prefetcha11_lw
2> <00>Test 22: prefetcha81_31
2> <00>Test 23: prefetcha11_15: illegal instruction trap
0>STATUS =PASSED

Power On Selftest Completed
```

3.4.3 POST Progress and Error Reporting

While POST is initialized, the Caps Lock key on the Sun Type-5 keyboard flashes on and off to indicate that POST tests are being executed. Additional POST progress indications are also visible when a TTY-type terminal or a tip line is connected between serial port A (default port) of the system being tested and a POST monitoring system.

If an error occurs during the POST execution, the keyboard Caps Lock key indicator stops flashing and an error code is displayed using the Caps Lock, Compose, Scroll Lock, and Num Lock key indicators. The error code indicates a particular system hardware failure.

Note – An error code may only be visible for a few seconds. Observe the Caps Lock, Compose, Scroll Lock, and Num Lock key indicators closely while POST is active.

In most cases, POST also attempts to send a failure message to the POST monitoring system. CODE EXAMPLE 3-3 identifies the typical appearance of a failure message. If a keyboard error code is displayed, determine the meaning of the error code by comparing the keyboard error code pattern to the corresponding error code meaning listed in TABLE 3-2.

Note – The system unit does not automatically boot if a POST error occurs; it halts at the ok prompt to alert the user of a failure.

CODE EXAMPLE 3-3 Typical Error Code Failure Message

```
Executing Power On SelfTest

0>
0>@(#) Sun UltraSPARC-II 2-way(Deuterium) UPA/PCI POST 1.0.3
08/15/97: 11:36
0>INFO: Processor 0 is master.
0>
0> <00> Init System BSS
0> <00> NVRAM Battery Detect Test
0> <00> NVRAM Scratch Addr Test
0> <00> DMMU TLB Tag Access Test
0> <00> DMMU TLB RAM Access Test
0> <00> Probe Ecache
0>INFO:CPU 296 MHz: 2048KB Ecache
0> <00> Ecache RAM Addr Test
0> <00> Ecache Tag Addr Test
0> <00> Invalidate Ecache Tags
0>INFO: Min Psycho configuration.
0>INFO: Processor 2 - UltraSPARC-II.
0> <00> Init SC Regs
0> <00> SC Address Reg Test
0> <00> SC Reg Index Test
0> <00> SC Regs Test
0> <00> SC Dtag RAM Addr Test
0> <00> SC Cache Size Init
```

CODE EXAMPLE 3-3 Typical Error Code Failure Message (Continued)

```
0> <00> SC Dtag Init
0> <00> Probe Memory
0>INFO:128MB Bank 0
0>INFO:No memory detected in Bank 1
0>INFO:No memory detected in Bank 2
0>INFO:No memory detected in Bank 3
0> <00> Malloc Post Memory
0> <00> Init Post Memory
0> <00> Post Memory Addr Test
0>mem_utils.c mem_err_bd_desc = 00000000.00000000, xor =
80808000.80808080
0>STATUS =FAILED
0>TEST =Post Memory Addr
TTF =0
PASSES =1
ERRORS =1
SUSPECT=SIMM U0801
0>MESSAGE=Mem Addr line compare error
    addr 00000000.00000000
    exp 00000000.00000000
    obs 80808000.80808080
0> xor 80808000.80808080

0> Verbose Data Path Information:
0> Addr = 00000000.00000000
0> PATH SUSPECT= SDB U0301
0> PATH SUSPECT= XBAR U301
0> <00>Memory Stack Test
0>STATUS =FAILED
0>TEST =Post Memory Addr
TTF =0
PASSES =1
ERRORS =1
SUSPECT=SIMM U0801
0>MESSAGE=Memory compare error
    addr 00000000.007f8080
    exp 55555555.557fd5d5
    obs 15151515.15151505
```

TABLE 3-2 Keyboard LED Patterns

Caps Lock	Compose	Scroll Lock	Num Lock	Meaning of Pattern
On	Off	Off	Off	System motherboard
Off	On	Off	Off	CPU module 0
Off	On	On	Off	CPU module 1
On	Off	Off	On	No memory detected
On	On	Off	Off	Memory bank 0
On	On	Off	On	Memory bank 1
On	On	On	Off	Memory bank 2
On	On	On	On	Memory bank 3
Off	Off	Off	On	NVRAM

3.5 Bypassing POST

POST can be disabled and thereby bypassed. To bypass POST:

- 1. Prior to powering on the system, press and hold the Stop key on the keyboard (FIGURE 3-2).**
- 2. With the Stop key pressed, turn on the system by pressing the power-on key.**

3.6 Additional Keyboard Control Commands

- Stop Key

If the `diag-level` is set to either `max` or `min` and the `diag-level switch?` variable is set to `true` and POST is not to be executed when the system is powered on, press and hold the keyboard Stop key and press the keyboard power-on key.

Note – Press and hold the Stop key for approximately 5 seconds.

- Stop and N Keys

To set the system NVRAM parameters to the original default settings, press and hold the Stop and N keys before powering on the system. Continue to hold the Stop and N keys until the system banner displays on the monitor.

3.7 System and Keyboard LEDs

The power light-emitting diode (LED), located at the chassis front, remains lighted when the system is operating normally. FIGURE 1-2 shows the location of the power LED.

While POST is executing and making progress, the Caps Lock key LED blinks while the rest of the LEDs are off. If POST finds an error, a pattern is encoded in the LEDs to indicate the defective part. If POST completes with no errors, all LEDs will be off and the system will return to the OpenBoot PROM (OBP). TABLE 3-2 defines the keyboard LED patterns. FIGURE 3-2 shows the location of the LED keys on the keyboard.

3.8 Initializing Motherboard POST

To initialize the motherboard POST:

1. **Power off the system unit.**
2. **At the keyboard, simultaneously press and hold the Stop and D keys and press the power-on key.**

Note – Video output is disabled while POST is initialized.

Note – If the POST output results are to be viewed, a tip connection must be set up. See Section 3.2.1, “Setting Up a Tip Connection” on page 3-3.

3. **Verify the keyboard LEDs light to confirm the system is in the POST mode and the keyboard Caps Lock key LED flashes on and off to indicate the system has enabled POST.**
4. **If a failure occurs during POST, a keyboard key LED other than the Caps Lock key LED may light, indicating a failed system component.**
See Section 3.7, “System and Keyboard LEDs” on page 3-22.
5. **If the Caps Lock key LED fails to flash after the Stop and D keys are pressed, POST has failed.**
See Section 3.7, “System and Keyboard LEDs” on page 3-22.

Note – The most probable cause of this type of failure is the motherboard. However, optional system components could also cause POST to fail.

6. **Before replacing the motherboard, remove any optional components, such as PCI cards and memory, and repeat the POST.**

Note – Non-optional components such as DIMMs, the motherboard, the power supply, and the keyboard must be installed for POST to execute properly. Removing the optional system components and retesting the system unit isolates the possibility that those components are the cause of the failure.

7. **To receive additional POST failure information, establish a tip connection.**

See Section 3.2.1, “Setting Up a Tip Connection” on page 3-3.

Troubleshooting Procedures

This chapter describes how to troubleshoot possible hardware problems and includes suggested corrective actions.

This chapter contains the following topics:

- Power-On Failure—page 4-2
- Video Output Failure—page 4-3
- Disk Drive or CD-ROM Drive Failure—page 4-3
- Power Supply Test—page 4-5
- DIMM Failure—page 4-7
- OpenBoot PROM On-Board Diagnostics—page 4-8
- OpenBoot Diagnostics—page 4-13

4.1 Power-On Failure

This section provides examples of power-on failure symptoms and suggested actions.

Symptom

The system unit does not power up when the keyboard power switch is pressed.

Action

Check the keyboard connection. Ensure that the keyboard is properly connected to the system unit. Check the AC power cord. Ensure that the AC power cord is properly connected to the system unit and to the wall receptacle. Verify that the wall receptacle is supplying AC power to the system unit.

Press the power switch. If the system unit powers on, the keyboard may be defective or the system unit is unable to accept the keyboard power-on signal. Power off the system unit and press the keyboard power-on switch again. If the system unit powers on, no further action is required. If the system unit does not power on, the CPU module may not be properly seated. Inspect the CPU module for proper seating. If the system unit powers on, no further action is required. If the system unit does not power on, the keyboard may be defective. Connect a spare Sun Type-5 keyboard to the system unit and press the power-on key.

If the wall receptacle AC power has been verified, the CPU module is properly seated, and a spare Sun Type-5 keyboard has been connected to the system unit and the power-on key has been pressed but the system unit does not power up, the system unit power supply may be defective. See Section 4.4, "Power Supply Test" on page 4-5.

Symptom

The system unit attempts to power up but does not boot or initialize the monitor.

Action

Press the keyboard power-on key and watch the keyboard. The keyboard LEDs should light briefly and a tone from the keyboard should be heard. If a tone is not heard or if the keyboard LEDs do not light briefly, the system unit power supply may be defective. See Section 4.4, “Power Supply Test” on page 4-5. If a keyboard tone is heard and the keyboard LEDs light briefly but the system unit still fails to initialize, see Section 3.8, “Initializing Motherboard POST” on page 3-23.

4.2 Video Output Failure

This section provides video output failure symptom and suggested action.

Symptom

No video at the system monitor.

Action

Check the monitor AC power cord. Ensure that the AC power cord is connected to the monitor and to the wall receptacle. Verify that the wall receptacle is supplying AC power to the monitor. Check the video cable connection between the monitor and the system graphics card output port at the rear of the system. Check that the CPU module is properly seated. If the AC connection to the monitor is correct, the video cable is correctly connected, and the CPU module is properly seated, the system monitor or the system graphics card may be defective. Replace the monitor or the graphics card.

4.3 Disk Drive or CD-ROM Drive Failure

This section provides hard drive and CD-ROM drive failure symptoms and suggested actions.

Symptom

A hard drive read, write, or parity error is reported by the operating system or customer application.

A CD-ROM drive read error or parity error is reported by the operating system or customer application.

Action

Replace the drive indicated by the failure message. The operating system identifies the internal drives as listed in TABLE 4-1.

TABLE 4-1 Internal Drives Identification

Operating System Address	Drive Physical Location and Target
c0t0d0s#	Lower hard drive, target 0
c0t1d0s#	Upper hard drive, target 1
c0t6d0s#	CD-ROM drive, target 6 (optional)
c0t5d0s#	Tape drive, target 5 (optional)

Note – The # symbol in the operating system address examples may be a numeral between 0 and 7 that describes the slice or partition on the drive.

Symptom

Hard drive or CD-ROM drive fails to respond to commands.

Note – To bypass POST, type: `setenv diag-switch? false` at the ok prompt.

Action

Test the drive response to the `probe-scsi` command as follows:

1. **At the system ok prompt:**
 - a. **Type** `reset-all`.
 - b. **Type** `probe-scsi`.

If the hard drive responds correctly to `probe-scsi`, the message identified in CODE EXAMPLE 4-4 is displayed. If the drives respond and a message is displayed, the system SCSI controller has successfully probed the devices. This is an indication that the motherboard is operating correctly. If one drive does not respond to the SCSI controller probe but the other does, replace the unresponsive drive. If one hard drive is configured with the system and the `probe-scsi` test fails to show the device in the message, replace the drive. If the problem is still evident after replacing the hard drive, replace the SCSI drive bay (see Section 8.3, “Hard Drive Bay With SCSI Assembly” on page 8-7) If replacing both the hard drive and the SCSI drive bay does not correct the problem, replace the motherboard.

4.4 Power Supply Test

The section describes how to test the power supply. FIGURE 4-1 and TABLE 4-2 identify power supply connector J2901. FIGURE 4-2 and TABLE 4-3 identify power supply connector J2902. FIGURE 4-3 and TABLE 4-4 identify power supply connector J2903.

1. **Power off the system.**
2. **Remove the side access cover.**
See Section 7.1, “Removing the Side Access Cover” on page 7-2.
3. **Slide the power supply from the chassis enough to expose connectors J2901 through J2903.**
4. **Power on the system.**
5. **Using a digital voltage meter (DVM), check the power supply output voltages as follows:**

Note – Power supply connectors J2901 through J2903 must remain connected to the motherboard.

- a. **With the negative probe of the DVM placed on a connector ground (Gnd) pin, position the positive probe on each power pin.**
 - b. **Verify voltage and signal availability as listed in TABLE 4-2, TABLE 4-3, and TABLE 4-4.**
6. **If any power pin signal is not present with the power supply active and properly connected to the motherboard, replace the power supply.**

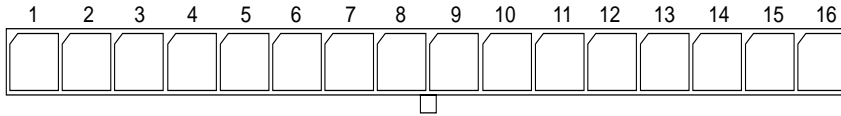

FIGURE 4-1 Power Supply Connector J2901

TABLE 4-2 Power Supply Connector J2901 Pin Description

Pin	Description	Pin	Description
1	Rtn	9	SUPPLY TRIP L
2	+3.3 Vdc SENSE	10	POWERON L
3	Rtn	11	-12 Vdc
4	+5.0 Vdc SENSE	12	POWER OK
5	POWER SET0 NEG	13	Gnd
6	+3.0 Vdc SENSE	14	+12 Vdc
7	POWER 0V	15	Rtn
8	POWER SET0 POS	16	+12 Vdc

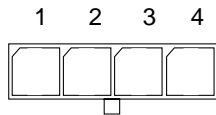

FIGURE 4-2 Power Supply Connector J2902

TABLE 4-3 Power Supply Connector J2902 Pin Description

Pin	Description	Pin	Description
1	+5.0 Vdc Rtn	3	+3.3 Vdc Rtn
2	+5.0 Vdc	4	+3.3 Vdc

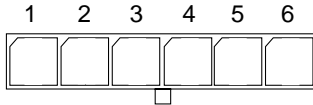

FIGURE 4-3 Power Supply Connector J2903

TABLE 4-4 Power Supply Connector J2903 Pin Description

Pin	Function	Pin	Function
1	+3.3 Vdc Rtn	4	+3.3 Vdc
2	+3.3 Vdc Rtn	5	+3.3 Vdc
3	+3.3 Vdc Rtn	6	+3.3 Vdc

4.5 DIMM Failure

At times, the operating system, diagnostic program, or POST may not display a DIMM location (U number) as part of a memory error message. In this situation, the only available information is a physical memory address and failing byte (or bit). TABLE 4-5 lists physical memory addresses to locate a defective DIMM.

TABLE 4-5 DIMM Physical Memory Address

DIMM Slot	DIMM Pair (non-interleave)
U0701	00000000 - 0ffffff
U0702	
U0703	10000000 - 1ffffff
U0704	
U0801	20000000 - 2ffffff
U0802	
U0803	30000000 - 3ffffff
U0804	
U0901	80000000 - 8ffffff
U0902	
U0903	90000000 - 9ffffff
U0904	
U1001	a0000000 - affffff
U1002	
U1003	b0000000 - bffffff
U1004	

4.6 OpenBoot PROM On-Board Diagnostics

The following sections describe the OpenBoot PROM (OBP) on-board diagnostics. To execute the OBP on-board diagnostics, the system must be at the `ok` prompt. The OBP on-board diagnostics are listed as follows:

- *watch-clock*—page 4-9
- *watch-net* and *watch-net-all*—page 4-9
- *probe-scsi* and *probe-scsi-all*—page 4-10
- *test* alias name, device path, *-all*—page 4-11
- UPA Graphics Card—page 4-12

4.6.1 watch-clock

`watch-clock` reads a register in the NVRAM/TOD chip and displays the result as a seconds counter. During normal operation, the seconds counter repeatedly increments from 0 to 59 until interrupted by pressing any key on the Sun Type-5 keyboard.

CODE EXAMPLE 4-1 identifies the `watch-clock` output message.

CODE EXAMPLE 4-1 watch-clock Output Message

```
{0} ok watch-clock
Watching the 'seconds' register of the real time clock chip.
It should be 'ticking' once a second.
Type any key to stop.
4
```

4.6.2 watch-net and watch-net-all

`watch-net` and `watch-net-all` monitor Ethernet packets on the Ethernet interfaces connected to the system. Good packets received by the system are indicated by a period (.). Errors such as the framing error and the cyclic redundancy check (CRC) error are indicated with an X and an associated error description.

CODE EXAMPLE 4-2 identifies the `watch-net` output message. CODE EXAMPLE 4-3 identifies the `watch-net-all` output message.

CODE EXAMPLE 4-2 watch-net Output Message

```
{0} ok watch-net
Hme register test --- succeeded.
Internal loopback test -- succeeded.
Transceiver check -- Using Onboard Transceiver - Link Up.
passed
Using Onboard Transceiver - Link Up.
Looking for Ethernet Packets.
`.` is a Good Packet. `X` is a Bad Packet.
Type any key to stop.
.....
```

CODE EXAMPLE 4-3 watch-net-all Output Message

```
{0} ok watch-net-all
/pci@1f,4000/network@1,1
Hme register test --- succeeded.
Internal loopback test -- succeeded.
Transceiver check -- Using Onboard Transceiver - Link Up.
passed
Using Onboard Transceiver - Link Up.
Looking for Ethernet Packets.
`.` is a Good Packet. `X` is a Bad Packet.
Type any key to stop.
...
```

4.6.3 probe-scsi and probe-scsi-all

`probe-scsi` transmits an inquiry command to internal and external SCSI devices connected to the system unit on-board SCSI interface. If the SCSI device is connected and active, the target address, unit number, device type, and manufacturer name is displayed. `probe-scsi-all` transmits an inquiry command to SCSI devices connected to the system SCSI host adapters. The first identifier listed in the display is the SCSI host adapter address in the system device tree followed by the SCSI device identification data.

CODE EXAMPLE 4-4 identifies the `probe-scsi` output message and CODE EXAMPLE 4-5 the `probe-scsi-all` output message.

CODE EXAMPLE 4-4 probe-scsi Output Message

```
ok probe-scsi
Target 0
  Unit 0   Disk      QUANTUM VK4550J   SUN4.2G8600
Target 6
  Unit 0   Removable Read Only device   TOSHIBA
XM5701TASUN12XCD0997
```

CODE EXAMPLE 4-5 probe-scsi-all Output Message

```
{0} ok probe-scsi
Target 0
  Unit 0   Disk      QUANTUM VK4550J   SUN4.2G8600
```

CODE EXAMPLE 4-5 probe-scsi-all Output Message (Continued)

```
Target 6
  Unit 0   Removable Read Only device   TOSHIBA
XM5701TASUN12XCD0997
{0} ok probe-scsi-all
/pci@1f,4000/scsi@3,1

/pci@1f,4000/scsi@3
Target 0
  Unit 0   Disk           QUANTUM VK4550J   SUN4.2G8600
Target 6
  Unit 0   Removable Read Only device   TOSHIBA
XM5701TASUN12XCD0997
```

4.6.4 test *alias name, device path, -all*

The test command, combined with a device alias or device path, enables a device self-test program. If a device has no self-test program, the message: No selftest method for *device name* is displayed. To enable the self-test program for a device, type the test command followed by the device alias or device path name.

CODE EXAMPLE 4-6 identifies the test output message. TABLE 4-6 lists test *alias name* selections, a description of the selection, and preparation.

Note – The diskette drive is selected as the test *alias name* example.

CODE EXAMPLE 4-6 test Output Message

```
ok test floppy
Testing floppy disk system.  A formatted disk should be in the
drive.
Test succeeded.
```

TABLE 4-6 Selected OBP On-Board Diagnostic Tests

Type of Test	Description	Preparation
test screen	Tests system video graphics hardware and monitor.	Diag-switch? NVRAM parameter must be true for the test to execute.
test floppy	Tests diskette drive response to commands.	A formatted diskette must be inserted into the diskette drive.
test net	Performs internal/external loopback test of the system auto-selected Ethernet interface.	An Ethernet cable must be attached to the system and to an Ethernet tap or hub or the external loopback test fails.
test ttya test ttyb	Outputs an alphanumeric test pattern on the system serial ports:ttya, serial port A; ttyb, serial port B.	A terminal must be connected to the port being tested to observe the output.
test keyboard	Executes the keyboard selftest.	Four keyboard LEDs should flash once and a message is displayed: <i>Keyboard Present</i> .
test -all	Sequentially test system-configured devices containing selftest.	Tests are sequentially executed in device-tree order (viewed with the <i>show-devs</i> command).

4.6.5 UPA Graphics Card

Note – The UPA graphics card includes the vertical, single buffer and vertical, DBZ graphic cards.

The UPA graphics card contains a built-in diagnostic test that is enabled through the OBP. The UPA graphics card built-in diagnostic test verifies basic graphics functionality without booting the operating system software.

To execute the built-in diagnostic test, the system must be at the `ok` prompt.

To initialize the UPA graphics card diagnostic:

1. At the `ok` prompt, type:

```
ok setenv diag-switch? true
diag-switch? = true
```

2. At the `ok` prompt, type:

```
ok% test screen

Verifying Console Mode for Frame Buffer Board
This will take a few minutes
Verifying Frame Buffer Memory used for console mode
This will take about two minutes
FFB Frame Buffer functional test passed
ok
```

3. When the UPA graphics card on-board diagnostics are completed, type:

```
ok% setenv diag-switch? false

diag-switch? = false
```

4.7 OpenBoot Diagnostics

The OpenBoot diagnostic (OBDiag) is a menu-driven set of diagnostics that verifies:

- PCI/Cheerio
- Ebus DMA/TCR registers
- Ethernet
- Keyboard
- Mouse
- Floppy
- Serial port A
- Serial port B
- NVRAM
- Audio
- SCSI
- All above

OBDiag performs root-cause failure analysis on the referenced devices by testing internal registers, confirming subsystem integrity, and verifying device functionality.

To initialize the OBDiag menu:

1. At the `ok` prompt, type: `obdiag`.

2. Verify that the OBDDiag screen is displayed (CODE EXAMPLE 4-7).

CODE EXAMPLE 4-7 OBDDiag Screen

```
{0} ok obddiag
stdin: fffeleb0
stdout: fffeleb8
loading code into: /pci@1f,4000/ebus@1
loading code into: /pci@1f,4000/ebus@1/eeeprom
loading code into: /pci@1f,4000/ebus@1/ecpp@14,3043bc
loading code into: /pci@1f,4000/ebus@1/su@14,3062f8
loading code into: /pci@1f,4000/ebus@1/se@14,400000
loading code into: /pci@1f,4000/network@1,1
loading code into: /pci@1f,4000/ebus@1/fdthree@14,3023f0
loading code into: /pci@1f,4000/ebus@1
SUNW,CS4231 Debugging enabled
```

3. At the ok prompt, type: obtest.

4. Verify that the OBDDiag menu is displayed (CODE EXAMPLE 4-8).

CODE EXAMPLE 4-8 OBDDiag Menu

```
OBDDiag Menu

0 ..... PCI/Cheerio
1 ..... EBUS DMA/TCR Registers
2 ..... Ethernet
3 ..... Keyboard
4 ..... Mouse
5 ..... Floppy
6 ..... Parallel Port
7 ..... Serial Port A
8 ..... Serial Port B
9 ..... NVRAM
10 ..... Audio
11 ..... SCSI
12 ..... All Above
13 ..... Quit
14 ..... Display this Menu
15 ..... Toggle script-debug
16 ..... Enable External Loopback Tests
17 ..... Disable External Loopback Tests

Enter (0-12 tests, 13 -Quit, 14 -Menu) ==>
```

5. At the OBDDiag menu prompt, type 15 to enable toggle script-debug messages.

4.7.1 PCI/Cheerio

The PCI/Cheerio diagnostic performs the following:

1. `vendor_ID_test` - Verifies the Cheerio ASIC vendor ID is 108e.
2. `device_ID_test` - Verifies the Cheerio ASIC device ID is 1000.
3. `mixmode_read` - Verifies the PCI configuration space is accessible as half-word bytes by reading the EBus2 vendor ID address.
4. `e2_class_test` - Verifies the address class code. Address class codes include bridge device (0 x B, 0 x 6), other bridge device (0 x A and 0 x 80), and programmable interface (0 x 9 and 0 x 0).
5. `status_reg_walk1` - Performs walk-one test on status register with mask 0 x 280 (Cheerio ASIC is accepting fast back-to-back transactions, DEVSEL timing is 0 x 1).
6. `line_size_walk1` - Performs tests 1 through 5.
7. `latency_walk1` - Performs walk one test on latency timer.
8. `line_walk1` - Performs walk one test on interrupt line.
9. `pin_test` - Verifies interrupt pin is logic-level high (1) after reset.

CODE EXAMPLE 4-9 identifies the PCI/Cheerio output message.

CODE EXAMPLE 4-9 PCI/Cheerio Output Message

```
Enter (0-12 tests, 13 -Quit, 14 -Menu) ==> 0

TEST='all_pci/cheerio_test'
SUBTEST='vendor_id_test'
SUBTEST='device_id_test'
SUBTEST='mixmode_read'
SUBTEST='e2_class_test'
SUBTEST='status_reg_walk1'
SUBTEST='line_size_walk1'
SUBTEST='latency_walk1'
SUBTEST='line_walk1'
SUBTEST='pin_test'
Enter (0-12 tests, 13 -Quit, 14 -Menu) ==>
```

4.7.2 EBus DMA/TCR Registers

The EBus DMA/TCR registers diagnostic performs the following:

1. `DMA_reg_test` - Performs a walking ones bit test for control status register, address register, and byte count register of each channel. Verifies that the control status register is set properly.
2. `DMA_func_test` - Validates the DMA capabilities and FIFOs. Test is executed in a DMA diagnostic loopback mode. Initializes the data of transmitting memory with its address, performs a DMA read and write, and verifies that the data received is correct. Repeats for four channels.

CODE EXAMPLE 4-10 identifies the EBus DMA/TCR registers output message.

CODE EXAMPLE 4-10 EBus DMA/TCR Registers Output Message

```
Enter (0-12 tests, 13 -Quit, 14 -Menu) ==> 1

TEST='all_dma/ebus_test'
SUBTEST='dma_reg_test'
SUBTEST='dma_func_test'
Enter (0-12 tests, 13 -Quit, 14 -Menu) ==>
```

4.7.3 Ethernet

The Ethernet diagnostic performs the following:

1. `my_channel_reset` - Resets the Ethernet channel.
2. `hme_reg_test` - Performs walk1 on the following registers set: global register 1, global register 2, bmac xif register, bmac tx register, and the mif register.
3. `MAC_internal_loopback_test` - Performs Ethernet channel engine internal loopback.
4. `10_mb_xcvr_loopback_test` - Enables the 10Base-T data present at the transmit MII data inputs to be routed back to the receive MII data outputs.
5. `100_mb_phy_loopback_test` - Enables MII transmit data to be routed to the MII receive data path.
6. `100_mb_twister_loopback_test` - Forces the twisted-pair transceiver into loopback mode.

CODE EXAMPLE 4-11 identifies the Ethernet output message.

CODE EXAMPLE 4-11 Ethernet Output Message

```
Enter (0-12 tests, 13 -Quit, 14 -Menu) ==> 2

TEST='ethernet_test'
SUBTEST='my_channel_reset'
SUBTEST='hme_reg_test'
SUBTEST='global_reg1_test'
SUBTEST='global_reg2_test'
SUBTEST='bmac_xif_reg_test'
SUBTEST='bmac_tx_reg_test'
SUBTEST='mif_reg_test'
SUBTEST='mac_internal_loopback_test'
SUBTEST='10mb_xcvr_loopback_test'
SUBTEST='100mb_phy_loopback_test'
Enter (0-12 tests, 13 -Quit, 14 -Menu) ==>
```

4.7.4 Keyboard

The keyboard diagnostic consists of an external and internal loopback. The external loopback requires a passive loopback connector. The internal loopback verifies the keyboard port by transmitting and receiving 128 characters.

CODE EXAMPLE 4-12 identifies the keyboard output message.

CODE EXAMPLE 4-12 Keyboard Output Message

```
Enter (0-12 tests, 13 -Quit, 14 -Menu) ==> 3

TEST='keyboard_test'
SUBTEST='internal_loopback'
Enter (0-12 tests, 13 -Quit, 14 -Menu) ==>
```

4.7.5 Mouse

The mouse diagnostic performs a keyboard-to-mouse loopback.

CODE EXAMPLE 4-13 identifies the mouse output message.

CODE EXAMPLE 4-13 Mouse Output Message

```
Enter (0-12 tests, 13 -Quit, 14 -Menu) ==> 4

TEST='mouse_test'
Enter (0-12 tests, 13 -Quit, 14 -Menu) ==>
```

4.7.6 Floppy

The floppy diagnostic verifies the diskette drive controller initialization. It also validates the status of a selected disk drive and reads the diskette drive header.

CODE EXAMPLE 4-14 identifies the floppy output message.

CODE EXAMPLE 4-14 Floppy Output Message

```
Enter (0-12 tests, 13 -Quit, 14 -Menu) ==> 5

TEST='floppy_test'
SUBTEST='floppy_id0_read_test'
Enter (0-12 tests, 13 -Quit, 14 -Menu) ==>
```

4.7.7 Parallel Port

The parallel port diagnostic performs the following:

1. `sio_passive_lb` - Sets up the SuperIO configuration register to enable extended/compatible parallel port select, then does a write 0, walk one, write 0 x ff to the data register. It verifies the results by reading the status register.
2. `dma_read` - Enables ECP mode and ECP DMA configuration, and FIFO test mode. Transfers 16 bytes of data from memory to the parallel port device and then verifies the data is in FIFO device.

CODE EXAMPLE 4-15 identifies the parallel port output message.

CODE EXAMPLE 4-15 Parallel Port Output Message

```
Enter (0-12 tests, 13 -Quit, 14 -Menu) ==> 6

TEST='parallel_port_test'
SUBTEST='dma_read'
Enter (0-12 tests, 13 -Quit, 14 -Menu) ==>
```

4.7.8 Serial Port A

The serial port A diagnostic invokes the `uart_loopback` test. The `uart_loopback` test transmits and receives 128 characters and checks the transaction validity. The following baud rates are tested in asynchronous mode: 460800, 307200, 230400, 153600, 76800, 57600, 38400, 19200, 9600, 4800, 2400, and 800.

CODE EXAMPLE 4-16 identifies the serial port A output message.

CODE EXAMPLE 4-16 Serial Port A Output Message

```
Enter (0-12 tests, 13 -Quit, 14 -Menu) ==> 7

TEST='uarta_test'
BAUDRATE='1200'
SUBTEST='internal_loopback'
BAUDRATE='1800'
SUBTEST='internal_loopback'
BAUDRATE='2400'
SUBTEST='internal_loopback'
BAUDRATE='4800'
SUBTEST='internal_loopback'
BAUDRATE='9600'
SUBTEST='internal_loopback'
BAUDRATE='19200'
SUBTEST='internal_loopback'
BAUDRATE='38400'
SUBTEST='internal_loopback'
BAUDRATE='57600'
SUBTEST='internal_loopback'
BAUDRATE='76800'
SUBTEST='internal_loopback'
BAUDRATE='115200'
SUBTEST='internal_loopback'
BAUDRATE='153600'
```

CODE EXAMPLE 4-16 Serial Port A Output Message (Continued)

```
SUBTEST='internal_loopback'  
BAUDRATE='230400'  
SUBTEST='internal_loopback'  
BAUDRATE='307200'  
SUBTEST='internal_loopback'  
BAUDRATE='460800'  
SUBTEST='internal_loopback'  
Enter (0-12 tests, 13 -Quit, 14 -Menu) ===>
```

Note – The serial port A diagnostic will stall if the TIP line is installed on serial port A. CODE EXAMPLE 4-17 identifies the serial port A output message when the TIP line is installed on serial port A.

CODE EXAMPLE 4-17 Serial Port A Output Message With TIP Line Installed

```
Enter (0-12 tests, 13 -Quit, 14 -Menu) ===> 7  
  
TEST='uarta_test'  
'UART A in use as console - Test not run.'  
Enter (0-12 tests, 13 -Quit, 14 -Menu) ===>
```

4.7.9 Serial Port B

The serial port B diagnostic is identical to the serial port A diagnostic.

CODE EXAMPLE 4-18 identifies the serial port B output message.

Note – The serial port B diagnostic will stall if the tip line is installed on serial port B.

CODE EXAMPLE 4-18 Serial Port B Output Message

```
Enter (0-12 tests, 13 -Quit, 14 -Menu) ==> 8

TEST='uartb_test'
BAUDRATE='1200'
SUBTEST='internal_loopback'
BAUDRATE='1800'
SUBTEST='internal_loopback'
BAUDRATE='2400'
SUBTEST='internal_loopback'
BAUDRATE='4800'
SUBTEST='internal_loopback'
BAUDRATE='9600'
SUBTEST='internal_loopback'
BAUDRATE='19200'
SUBTEST='internal_loopback'
BAUDRATE='38400'
SUBTEST='internal_loopback'
BAUDRATE='57600'
SUBTEST='internal_loopback'
BAUDRATE='76800'
SUBTEST='internal_loopback'
BAUDRATE='115200'
SUBTEST='internal_loopback'
BAUDRATE='153600'
SUBTEST='internal_loopback'
BAUDRATE='230400'
SUBTEST='internal_loopback'
BAUDRATE='307200'
SUBTEST='internal_loopback'
BAUDRATE='460800'
SUBTEST='internal_loopback'
Enter (0-12 tests, 13 -Quit, 14 -Menu) ==>
```

4.7.10 NVRAM

The NVRAM diagnostic verifies the NVRAM operation by performing a write and read to the NVRAM.

CODE EXAMPLE 4-19 identifies the NVRAM output message.

CODE EXAMPLE 4-19 NVRAM Output Message

```
Enter (0-12 tests, 13 -Quit, 14 -Menu) ==> 9

TEST='nvram_test'
SUBTEST='write/read_patterns'
SUBTEST='write/read_inverted_patterns'
Enter (0-12 tests, 13 -Quit, 14 -Menu) ==>
```

4.7.11 Audio

The audio diagnostic performs the following:

1. cs4231_test - Verifies the cs4231 internal registers.
2. Line-in to line-out external loopback.
3. Microphone to headphone external loopback.

CODE EXAMPLE 4-20 identifies the audio output message.

CODE EXAMPLE 4-20 Audio Output Message

```
Enter (0-12 tests, 13 -Quit, 14 -Menu) ==> 10

TEST='audio_test'
SUBTEST='cs4231_test'
Codec_ID='8a'
Version_ID='a0'
Enter (0-12 tests, 13 -Quit, 14 -Menu) ==>
```

4.7.12 SCSI

The SCSI diagnostic validates both the SCSI chip and the SCSI bus subsystem.

CODE EXAMPLE 4-21 identifies the SCSI output message.

CODE EXAMPLE 4-21 SCSI Output Message

```
Enter (0-12 tests, 13 -Quit, 14 -Menu) ==> 11

TEST='selftest'
Enter (0-12 tests, 13 -Quit, 14 -Menu) ==>
```

4.7.13 All Above

The all above diagnostic validates the system unit.

CODE EXAMPLE 4-22 identifies the all above output message.

Note – The all above diagnostic will stall if the tip line is installed on serial port A or serial port B.

CODE EXAMPLE 4-22 All Above Output Message

```
Enter (0-12 tests, 13 -Quit, 14 -Menu) ==> 12

TEST='all_pci/cheerio_test'
SUBTEST='vendor_id_test'
SUBTEST='device_id_test'
SUBTEST='mixmode_read'
SUBTEST='e2_class_test'
SUBTEST='status_reg_walk1'
SUBTEST='line_size_walk1'
SUBTEST='latency_walk1'
SUBTEST='line_walk1'
SUBTEST='pin_test'

TEST='all_dma/ebus_test'
SUBTEST='dma_reg_test'
SUBTEST='dma_func_test'

TEST='ethernet_test'
SUBTEST='my_channel_reset'
```

CODE EXAMPLE 4-22 All Above Output Message (Continued)

```
SUBTEST='hme_reg_test'
SUBTEST='global_reg1_test'
SUBTEST='global_reg2_test'
SUBTEST='bmac_xif_reg_test'
SUBTEST='bmac_tx_reg_test'
SUBTEST='mif_reg_test'
SUBTEST='mac_internal_loopback_test'
SUBTEST='10mb_xcvr_loopback_test'
SUBTEST='100mb_phy_loopback_test'

TEST='keyboard_test'
SUBTEST='internal_loopback'

TEST='mouse_test'

TEST='floppy_test'
SUBTEST='floppy_id0_read_test'

TEST='parallel_port_test'
SUBTEST='dma_read'

TEST='uarta_test'
'UART A in use as console - Test not run.'

TEST='uartb_test'
BAUDRATE='1200'
SUBTEST='internal_loopback'
BAUDRATE='1800'
SUBTEST='internal_loopback'
BAUDRATE='2400'
SUBTEST='internal_loopback'
BAUDRATE='4800'
SUBTEST='internal_loopback'
BAUDRATE='9600'
SUBTEST='internal_loopback'
BAUDRATE='19200'
SUBTEST='internal_loopback'
BAUDRATE='38400'
SUBTEST='internal_loopback'
BAUDRATE='57600'
SUBTEST='internal_loopback'
BAUDRATE='76800'
SUBTEST='internal_loopback'
BAUDRATE='115200'
SUBTEST='internal_loopback'
BAUDRATE='153600'
SUBTEST='internal_loopback'
```

CODE EXAMPLE 4-22 All Above Output Message (*Continued*)

```
BAUDRATE='230400'  
SUBTEST='internal_loopback'  
BAUDRATE='307200'  
SUBTEST='internal_loopback'  
BAUDRATE='460800'  
SUBTEST='internal_loopback'  
  
TEST='nvram_test'  
SUBTEST='write/read_patterns'  
SUBTEST='write/read_inverted_patterns'  
  
TEST='audio_test'  
SUBTEST='cs4231_test'  
Codec_ID='8a'  
Version_ID='a0'  
  
TEST='selftest'  
Enter (0-12 tests, 13 -Quit, 14 -Menu) ===>
```

Safety and Tool Requirements

This chapter describes the safety requirements, symbols, safety precautions, and tools required.

This chapter contains the following topics:

- Safety Requirements—page 5-2
- Symbols—page 5-2
- Safety Precautions—page 5-3
- Tools Required—page 5-4

5.1 Safety Requirements

For protection, observe the following safety precautions when setting up the equipment:

- Follow all cautions, warnings, and instructions marked on the equipment.
- Ensure that the voltages and frequency rating of the power receptacle match the electrical rating label on the equipment.
- Never push objects of any kind through openings in the equipment. They may touch dangerous voltage points or short components resulting in fire or electric shock.
- Refer servicing of equipment to qualified personnel.

5.2 Symbols

The following symbols mean:



Caution – Risk of personal injury and equipment damage. Follow the instructions.



Caution – Hazardous voltages are present. To reduce the risk of electric shock and danger to personal health, follow the instructions.



Caution – Hot surfaces. Avoid contact. Surfaces are hot and may cause personal injury if touched.

5.3 Safety Precautions

Follow all safety precautions.

5.3.1 Modification to Equipment



Caution – Do not make mechanical or electrical modifications to the equipment. Sun Microsystems is not responsible for regulatory compliance of a modified Sun product.

5.3.2 Placement of a Sun Product



Caution – To ensure reliable operation of the Sun product and to protect it from overheating, openings in the equipment must not be blocked or covered. A Sun product should never be placed near a radiator or hot air register.

5.3.3 Power Cord Connection



Caution – Not all power cords have the same current ratings. Household extension cords do not have overload protection. Do not use household extension cords with the Sun product.



Caution – The power switch of this product functions as a standby type device only. The power cord serves as the primary disconnect device for the system. Be sure to connect the power cord into a grounded electrical receptacle that is nearby the system and is readily accessible. Do not connect the power cord when the power supply has been removed from the system chassis.

5.3.4 Electrostatic Discharge



Caution – DIMMs, circuit boards, and hard drives contain electronic components that are extremely sensitive to static electricity. Ordinary amounts of static electricity from clothes or work environment can destroy components. Do not touch the components themselves or any metal parts. Wear the wrist strap when the system unit access panel is open.

5.3.5 Lithium Battery



Caution – On Sun system boards, a lithium battery is molded into the real-time clock, SDS No. M48T59Y, MK48TXXB-XX, M48T18-XXXPCZ or M48T59W-XXXPCZ. Batteries are not customer replaceable parts. They may explode if mistreated. Do not dispose of the battery in fire. Do not disassemble it or attempt to recharge the lithium battery.

5.4 Tools Required

The following tools are required to service the Ultra 60 computer (system unit).

- No. 2 Phillips screwdriver (magnetized tip suggested)
- Needle-nose pliers
- Grounding wrist strap
- Digital voltage meter (DVM)
- Antistatic mat

Place ESD-sensitive components such as motherboard, circuit cards, hard drives, DIMMs, and TOD/NVRAM on an antistatic mat. The following items can be used as an antistatic mat:

- Bag used to wrap a Sun replacement part
- Shipping container used to package a Sun replacement part
- Inner side (metal part) of the system unit cover
- Sun ESD mat, part number 250-1088 (can be purchased through your Sun sales representative)
- Disposable ESD mat; shipped with replacement parts or optional system features

Power On and Off

This chapter contains procedures to power on and power off the Ultra 60 computer.

This chapter contains the following topics:

- Powering On the System Unit—page 6-2
- Powering Off the System Unit—page 6-3

Note – The actions required to remove and replace the major subassemblies are also illustrated with photographs and audio/visual instructions on the *Sun Ultra 60 ShowMe How Multimedia Documentation*, part number 704-5886.

6.1 Powering On the System Unit

To power on the system unit:

1. Turn on power to all connected peripherals.

Note – Peripheral power is activated prior to system power so the system can recognize the peripherals when it is activated.

2. Connect the AC power cord.
3. Set the front panel power switch to the On position (FIGURE 6-1) or press the Sun Type-5 keyboard power on key (FIGURE 6-2).
4. Verify the following:
 - a. The front panel LED is on.
 - b. The system fans are spinning.

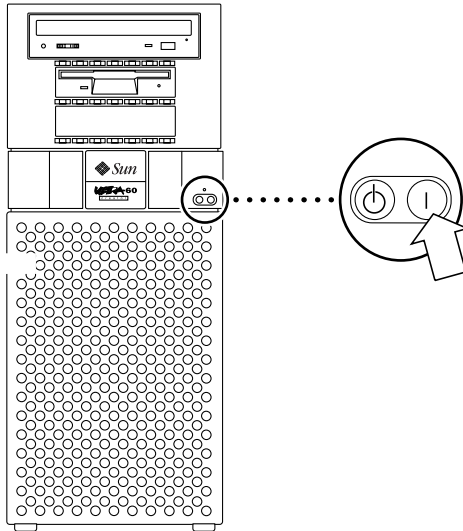

FIGURE 6-1 System Unit Power-On (Front Panel)

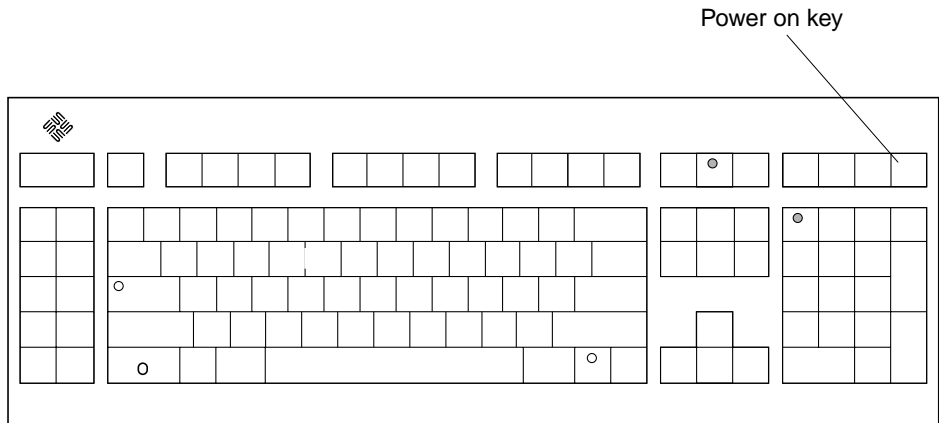

FIGURE 6-2 Sun Type-5 Keyboard

6.2 Powering Off the System Unit



Caution – Prior to turning off the system unit power, exit from the operating system. Failure to do so may result in data loss.



Caution – Wear an antistatic wrist strap and use an ESD-protected mat when handling components. When servicing or removing system unit components, attach an ESD strap to your wrist, then to a metal area on the chassis, and then disconnect the power cord from the system unit and the wall receptacle. Following this caution equalizes all electrical potentials with the system unit.

To power off the system unit:

1. **Back up system files and data.**
2. **Halt the system.**



Caution – Pressing the front panel power switch does not remove all power from the system unit; a trickle voltage remains in the power supply. To remove all power from the system unit, disconnect the AC power cord.

3. **Set the front panel power switch to the Off position (FIGURE 6-3).**

4. Verify the following:
 - a. The front panel LED is off.
 - b. The system fans are not spinning.



Caution – Disconnect the AC power cord prior to servicing system components.

5. Turn off the power to the monitor.
6. Disconnect cables to any peripheral equipment.

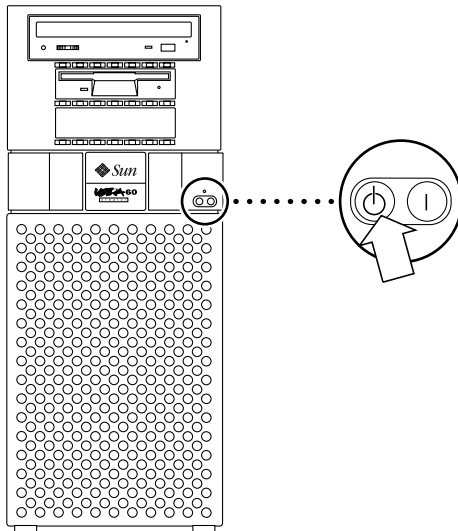

FIGURE 6-3 System Unit Power-Off (Front Panel)

Internal Access

This chapter describes how to access the Ultra 60 computer for service.

This chapter contains the following topics:

- Removing the Side Access Cover—page 7-2
- Attaching the Wrist Strap—page 7-3
- Replacing the Side Access Cover—page 7-4

Note – Removal and replacement of selected system unit components are also illustrated with photographs and audio/visual instructions on the *Sun Ultra 60 ShowMe How Multimedia Documentation*, part number 704-5886.

7.1 Removing the Side Access Cover

1. Power off the system unit.

See Section 6.2, “Powering Off the System Unit” on page 6-3.

2. Disconnect the lock block (FIGURE 7-1).

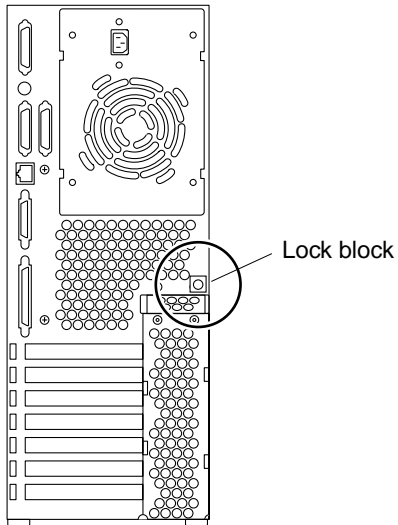

FIGURE 7-1 Lock Block Location

3. Remove the side access cover as follows (FIGURE 7-2):

- a. Lay the system in the service position.
- b. Grasp the side panel and pull it toward the back of the system.
- c. Disengage the side access cover from the chassis hooks.
- d. Grasping the access cover sides, lift the side access cover upward and remove.

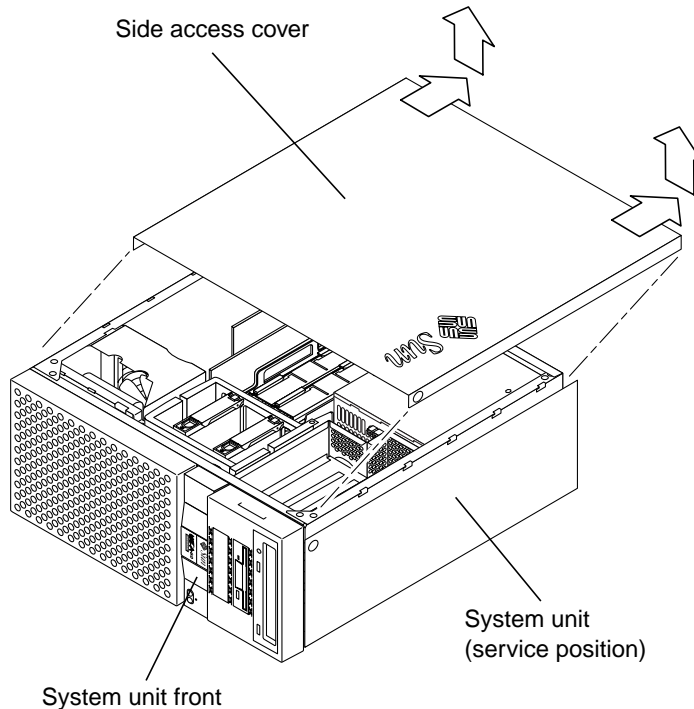

FIGURE 7-2 Removing the Side Access Cover

7.2 Attaching the Wrist Strap



Caution – Wear an antistatic wrist strap and use an ESD-protected mat when handling components. When servicing or removing system unit components, attach an ESD strap to your wrist, then to a metal area on the chassis, and then disconnect the power cord from the system unit and the wall receptacle. Following this caution equalizes all electrical potentials with the system unit.

1. Unwrap the first two folds of the wrist strap; wrap the adhesive side firmly against the wrist.
2. Peel the liner from the copper foil at the opposite end of the wrist strap.
3. Attach the copper end of the wrist strap to the chassis (FIGURE 7-3).
4. Disconnect the AC power cord.

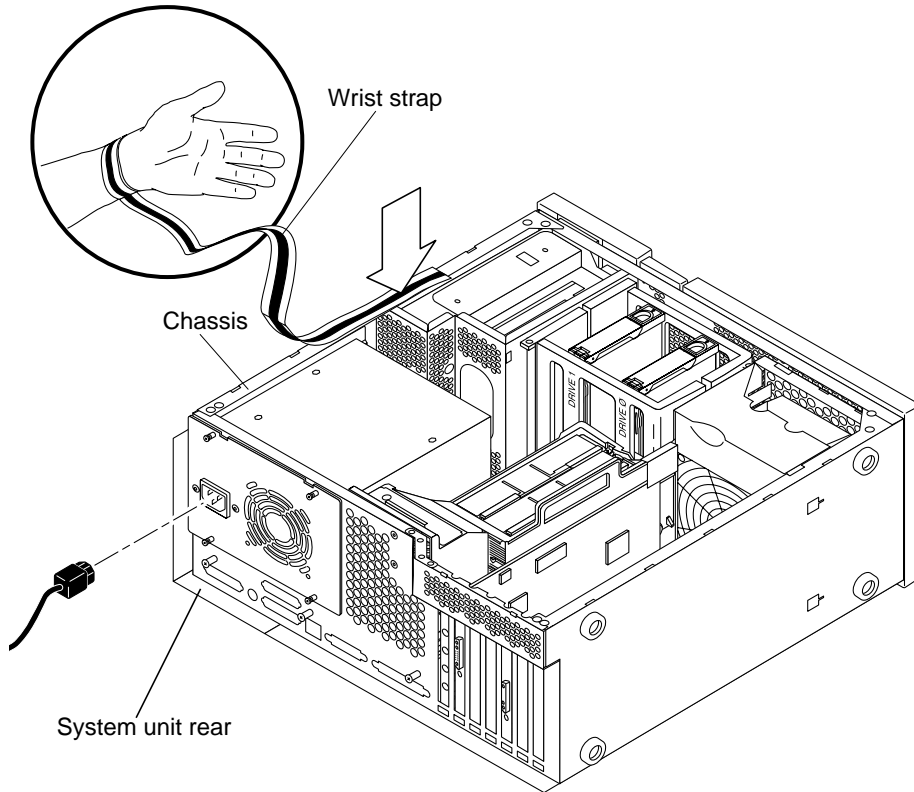

FIGURE 7-3 Attaching the Wrist Strap to the Chassis

7.3 Replacing the Side Access Cover

1. Position the side access cover (FIGURE 7-4).
2. Engage the side access cover and the chassis hooks. Push the access cover towards the system unit front.
3. Connect the lock block (FIGURE 7-1).
4. Position the system unit in the operating position.

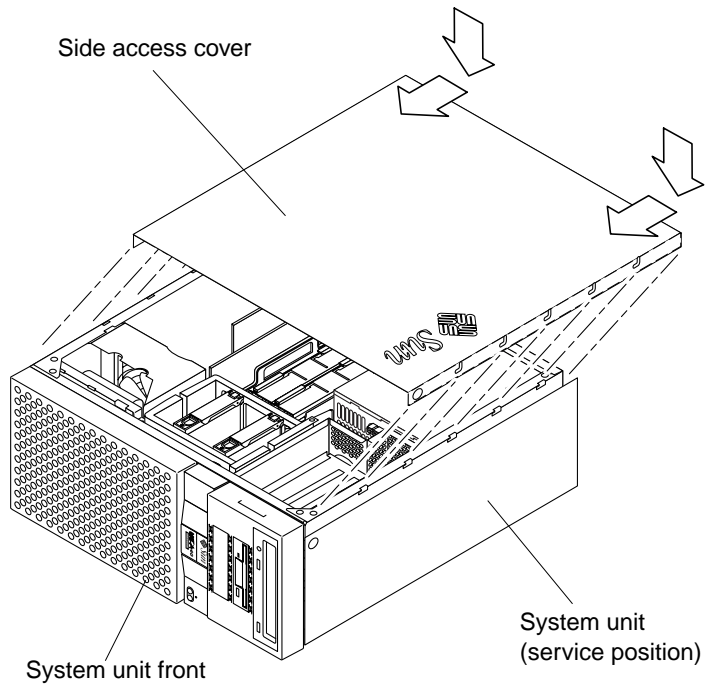

FIGURE 7-4 Replacing the Side Access Cover

Major Subassemblies

This chapter describes how to remove and replace the major subassemblies.

This chapter contains the following topics:

- Power Supply—page 8-2
- PCI Fan Assembly—page 8-5
- Hard Drive Bay With SCSI Assembly—page 8-7
- Cable Assemblies—page 8-11
- EMI Filler Panels—page 8-14
- Chassis Foot—page 8-16
- Speaker Assembly—page 8-17
- DC Switch Assembly—page 8-19
- CPU Fan Assembly—page 8-36
- Shroud Assembly—page 8-38

Note – The actions required to remove and replace the major subassemblies are also illustrated with photographs and audio/visual instructions on the *Sun Ultra 60 ShowMe How Multimedia Documentation*, part number 704-5886.

8.1 Power Supply

To remove and replace the power supply, proceed as follows.

8.1.1 Removing the Power Supply

1. Power off the system unit.

See Section 6.2, “Powering Off the System Unit” on page 6-3.

2. Remove the side access cover.

See Section 7.1, “Removing the Side Access Cover” on page 7-2.



Caution – When removing the power supply, attach the copper end of the wrist strap to the system unit chassis, not the power supply.

3. Attach the wrist strap.

See Section 7.2, “Attaching the Wrist Strap” on page 7-3.

4. Remove the power supply as follows (FIGURE 8-1 and FIGURE 8-2):

a. Using a number 2 Phillips-head screwdriver, loosen the four captive screws securing the power supply to the chassis.

b. Slide the power supply from the chassis rear until the power supply is stopped by the power supply cables.

c. Disconnect the peripheral cable connector from the power supply (not illustrated).

d. Disconnect the power supply cables from the motherboard (not illustrated).

e. Remove the power supply from the chassis.

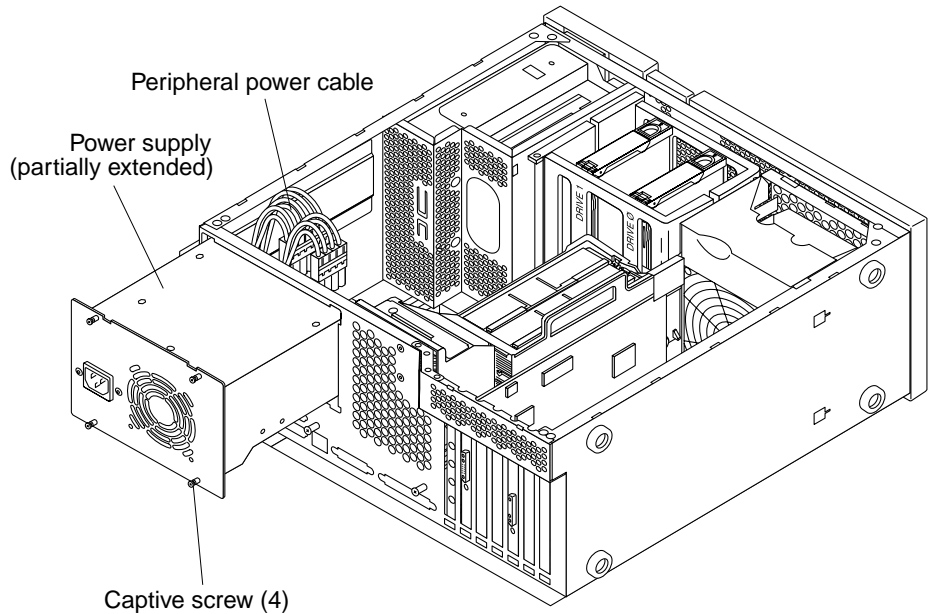

FIGURE 8-1 Removing and Replacing the Power Supply (Part 1 of 2)

8.1.2 Replacing the Power Supply



Caution – Use proper ESD grounding techniques when handling components. Wear an antistatic wrist strap and use an ESD-protected mat. Store ESD-sensitive components in antistatic bags before placing them on any surface.

1. **Replace the power supply as follows (FIGURE 8-1 and FIGURE 8-2):**
 - a. **Feed the power supply cables through the chassis opening; support the power supply cables while engaging the power supply into the chassis rails.**
 - b. **Position the power supply into the chassis.**
 - c. **Slide the power supply toward the chassis front.**
 - d. **Connect the power cables to the motherboard.**
 - e. **Connect the peripheral cable connector to the power supply.**
 - f. **Replace the peripheral power cable through the cable routing clips.**

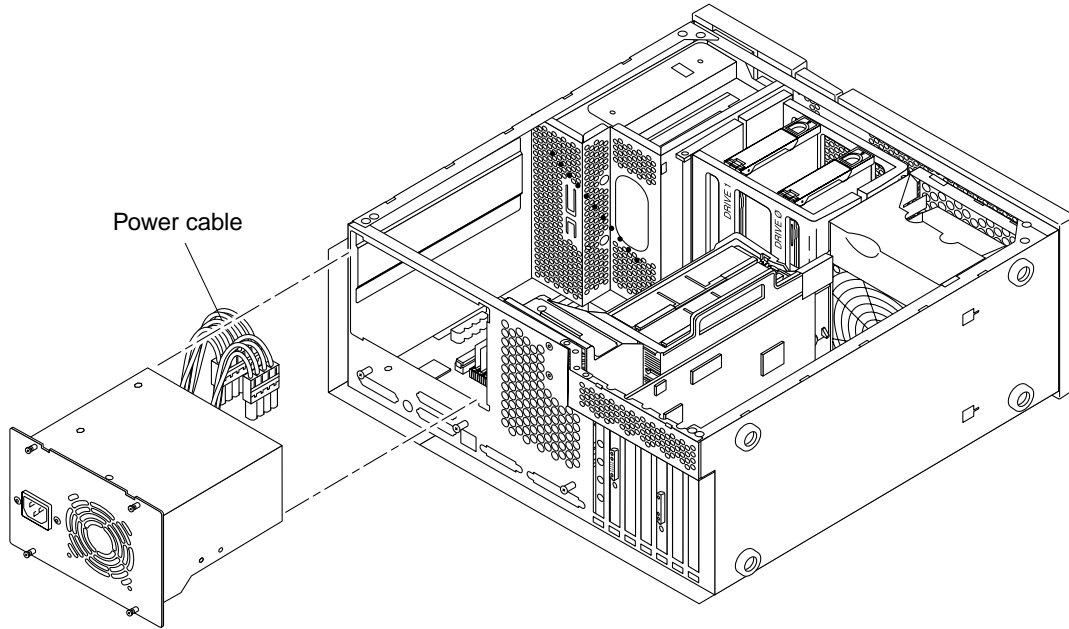

FIGURE 8-2 Removing and Replacing the Power Supply (Part 2 of 2)

- g. Slide the power supply toward the chassis front until the power supply rear panel is flush with the chassis.**
- h. Using a number 2 Phillips-head screwdriver, tighten the captive screws securing the power supply to the chassis.**

Note – Tighten the captive screws in a clockwise order beginning with the upper right captive screw.

- 2. Connect the AC power cord.**
- 3. Detach the wrist strap.**
- 4. Replace the side access cover.**
See Section 7.3, “Replacing the Side Access Cover” on page 7-4.
- 5. Power on the system unit.**
See Section 6.1, “Powering On the System Unit” on page 6-2.

8.2 PCI Fan Assembly

To remove and replace the PCI fan assembly, proceed as follows.

8.2.1 Removing the PCI Fan Assembly

1. Power off the system unit.

See Section 6.2, “Powering Off the System Unit” on page 6-3.

2. Remove the side access cover.

See Section 7.1, “Removing the Side Access Cover” on page 7-2.



Caution – Use proper ESD grounding techniques when handling components. Wear an antistatic wrist strap and use an ESD-protected mat. Store ESD-sensitive components in antistatic bags before placing them on any surface.

3. Attach the wrist strap.

See Section 7.2, “Attaching the Wrist Strap” on page 7-3.

4. Disconnect the PCI fan assembly as follows (FIGURE 8-3):

a. Remove any long PCI cards.

See Section 10.3.1, “Removing a PCI Card” on page 10-7.

b. Disconnect the PCI fan power harness from the motherboard.

c. Press the locking snap and disengage.

d. Disengage the studs from the chassis slot.

5. Remove the PCI fan assembly by moving it back, over, and up.

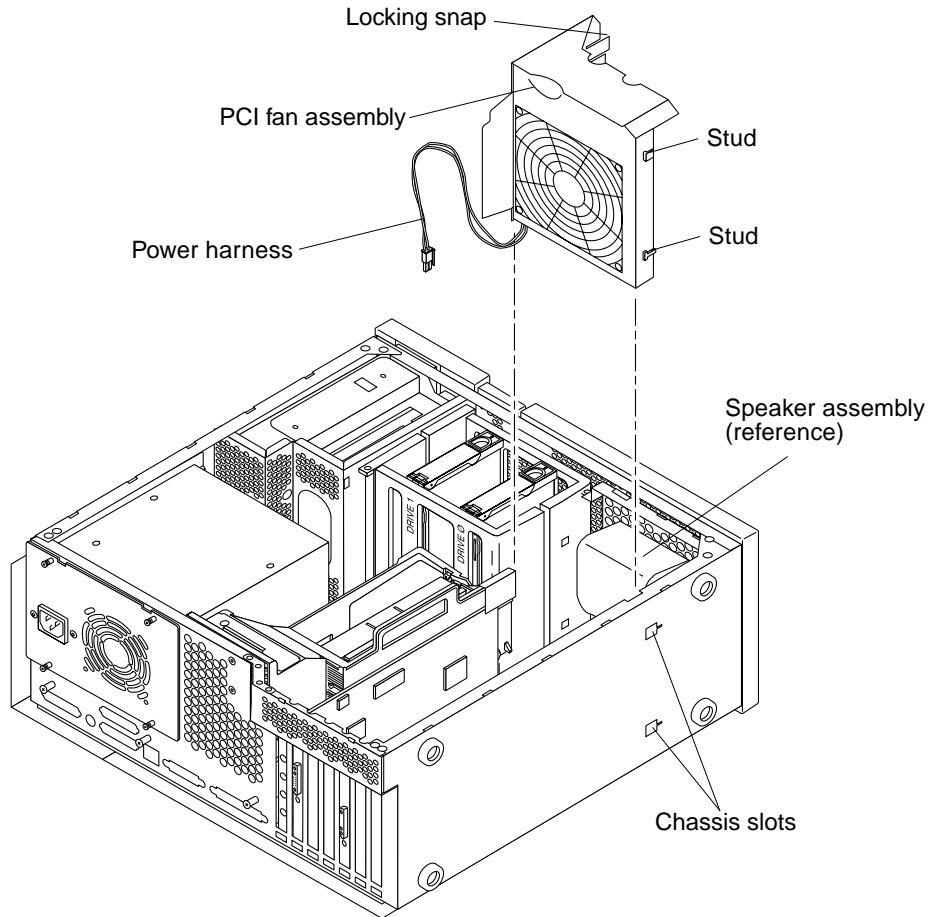

FIGURE 8-3 Removing and Replacing the PCI Fan Assembly

8.2.2 Replacing the PCI Fan Assembly



Caution – Use proper ESD grounding techniques when handling components. Wear an antistatic wrist strap and use an ESD-protected mat. Store ESD-sensitive components in antistatic bags before placing them on any surface.

1. Position the PCI fan over the speaker assembly (FIGURE 8-3).
2. Connect the PCI fan as follows:

- a. **Position the studs into the chassis slots and engage.**
 - b. **Press the locking snap and engage.**
 - c. **Connect the power harness to the motherboard.**
 - d. **Replace any long PCI cards.**
See Section 10.3.2, “Replacing a PCI Card” on page 10-9.
3. **Connect the AC power cord.**
 4. **Detach the wrist strap.**
 5. **Replace the side access cover.**
See Section 7.3, “Replacing the Side Access Cover” on page 7-4.
 6. **Power on the system unit.**
See Section 6.1, “Powering On the System Unit” on page 6-2.

8.3 Hard Drive Bay With SCSI Assembly

To remove and replace the hard drive bay with SCSI assembly (SCSI drive bay), proceed as follows.

8.3.1 Removing the SCSI Drive Bay

1. **Power off the system unit.**
See Section 6.2, “Powering Off the System Unit” on page 6-3.
2. **Remove the side access cover.**
See Section 7.1, “Removing the Side Access Cover” on page 7-2.



Caution – Use proper ESD grounding techniques when handling components. Wear an antistatic wrist strap and use an ESD-protected mat. Store ESD-sensitive components in antistatic bags before placing them on any surface.

3. **Attach the wrist strap.**
See Section 7.2, “Attaching the Wrist Strap” on page 7-3.

- 4. Remove the SCSI drive bay as follows (FIGURE 8-4):**
 - a. Remove the hard drive(s).**

See Section 9.1.1, "Removing a Hard Drive" on page 9-2.
 - b. Disconnect the SCSI cables from the motherboard connectors.**
 - c. Disconnect the peripheral power cable.**
 - d. Remove the peripheral power cable from the cable routing clips.**
 - e. Remove the diskette drive cable from the plastic spring clips installed adjacent to the drive bay.**
 - f. Unfeed the peripheral power cable through the chassis opening.**
 - g. Using a number 2 Phillips-head screwdriver, remove the screws securing the SCSI drive bay to the chassis.**
 - h. Feed the SCSI cable under the PCI fan bracket while pulling up in Step g.**
 - i. Slide the SCSI drive bay out of the chassis.**

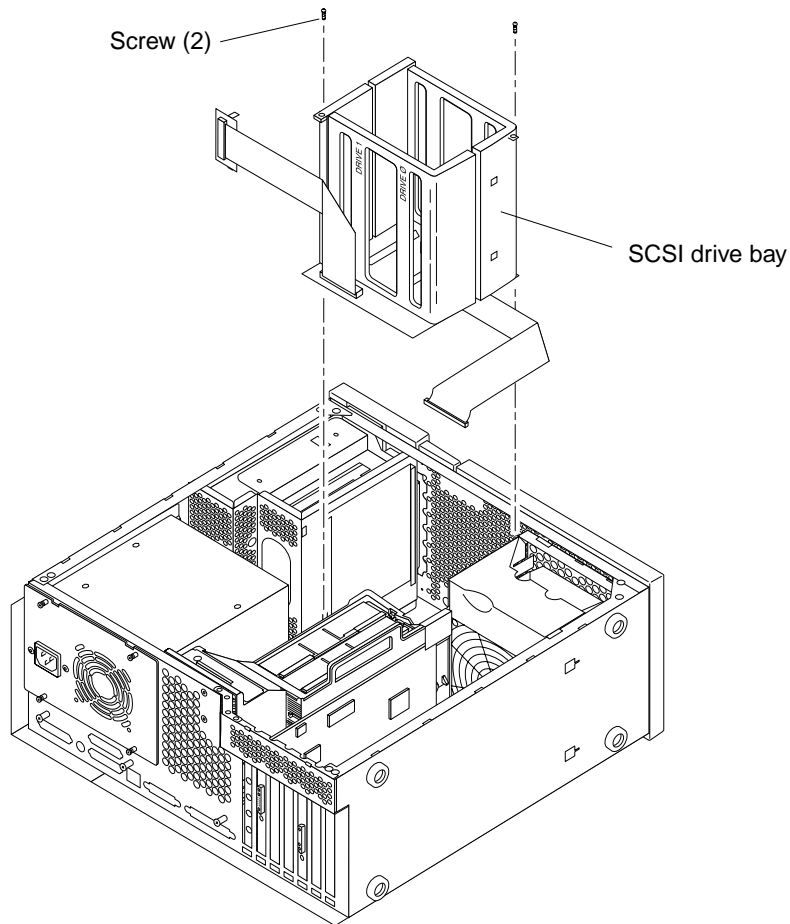

FIGURE 8-4 Removing and Replacing the SCSI Drive Bay

8.3.2 Replacing the SCSI Drive Bay



Caution – Use proper ESD grounding techniques when handling components. Wear an antistatic wrist strap and use an ESD-protected mat. Store ESD-sensitive components in antistatic bags before placing them on any surface.

1. **Replace the SCSI drive bay as follows (FIGURE 8-4):**
 - a. **Position the SCSI drive bay on the channel slides and slide it in.**

- b. Using a number 2 Phillips-head screwdriver, replace the screws securing the SCSI drive bay to the chassis.
- c. Connect the SCSI cables to the motherboard connectors.
- d. Press the SCSI cables into the cage hole and beneath the PCI fan assembly.
- e. Replace the peripheral power cable into the cable routing clips.
- f. Replace the diskette drive cable into the plastic spring clips installed adjacent to the drive bay.
- g. Replace the hard drive(s).
See Section 9.1.2, "Replacing a Hard Drive" on page 9-3.

Note – Hooks at the chassis base must lock into the bottom holes of the drive bracket.

- 2. **Connect the AC power cord.**
- 3. **Detach the wrist strap.**
- 4. **Replace the side access cover.**
See Section 7.3, "Replacing the Side Access Cover" on page 7-4.
- 5. **Power on the system unit.**
See Section 6.1, "Powering On the System Unit" on page 6-2.

8.4 Cable Assemblies

To remove and replace the peripheral power cable assembly and the diskette drive cable assembly, proceed as follows.

Note – Unconnected peripheral power cables should remain clipped inside the main chassis.

8.4.1 Removing the Peripheral Power Cable Assembly

1. Power off the system unit.

See Section 6.2, “Powering Off the System Unit” on page 6-3.

2. Remove the side access cover.

See Section 7.1, “Removing the Side Access Cover” on page 7-2.



Caution – Use proper ESD grounding techniques when handling components. Wear an antistatic wrist strap and use an ESD-protected mat. Store ESD-sensitive components in antistatic bags before placing them on any surface.

3. Attach the wrist strap.

See Section 7.2, “Attaching the Wrist Strap” on page 7-3.

4. Disconnect the peripheral power cable assembly as follows:

a. Remove the peripheral power cable connector from the power supply.

b. Partially remove the drive tray.

See Section 9.2.1, “Removing the RMA” on page 9-4.

c. Remove the peripheral power cable connector from the CD-ROM drive (or tape drive) and the diskette drive.

d. Remove the peripheral power cable connector from the hard drive SCSI subassembly.

5. Remove the peripheral power cable from the cable routing clips.

6. Remove the peripheral power cable assembly.

8.4.2 Replacing the Peripheral Power Cable Assembly



Caution – Use proper ESD grounding techniques when handling components. Wear an antistatic wrist strap and use an ESD-protected mat. Store ESD-sensitive components in antistatic bags before placing them on any surface.

1. **Position the peripheral power cable assembly into the chassis.**
2. **Replace the peripheral power cable through the cable routing clips.**
3. **Connect the following:**
 - a. **Replace the peripheral power cable connector to the hard drive SCSI subassembly.**
 - b. **Replace the peripheral power cable connector to the CD-ROM drive (or tape drive) and the diskette drive.**
 - c. **Replace the drive tray.**
See Section 9.2.6, “Replacing the RMA” on page 9-9.
 - d. **Replace the peripheral power cable connector to the power supply.**
4. **Connect the AC power cord.**
5. **Detach the wrist strap.**
6. **Replace the side access cover.**
See Section 7.3, “Replacing the Side Access Cover” on page 7-4.
7. **Power on the system unit.**
See Section 6.1, “Powering On the System Unit” on page 6-2.

8.4.3 Removing the Diskette Drive Cable Assembly

1. **Power off the system unit.**
See Section 6.2, “Powering Off the System Unit” on page 6-3.
2. **Remove the side access cover.**
See Section 7.1, “Removing the Side Access Cover” on page 7-2.



Caution – Use proper ESD grounding techniques when handling components. Wear an antistatic wrist strap and use an ESD-protected mat. Store ESD-sensitive components in antistatic bags before placing them on any surface.

3. Attach the wrist strap.

See Section 7.2, “Attaching the Wrist Strap” on page 7-3.

4. Disconnect the diskette drive cable assembly as follows:

a. Partially remove the drive tray.

See Section 9.2.1, “Removing the RMA” on page 9-4.

b. Disconnect the SCSI cable from the CD-ROM drive (or tape drive) and unfeed the cable through the chassis opening to expose the diskette drive cable (underneath).

c. Remove the diskette drive cable connector from the diskette drive.

d. Remove the diskette drive cable from the plastic spring clips installed adjacent to the drive bay.

e. Remove the diskette drive cable connector from the motherboard.

5. Remove the diskette drive cable assembly.

8.4.4

Replacing the Diskette Drive Cable Assembly



Caution – Use proper ESD grounding techniques when handling components. Wear an antistatic wrist strap and use an ESD-protected mat. Store ESD-sensitive components in antistatic bags before placing them on any surface.

1. Position the diskette drive cable assembly into the chassis.

2. Connect the following:

a. Replace the diskette drive cable connector to the motherboard.

b. Replace the diskette drive cable into the plastic spring clips installed adjacent to the drive bay.

c. Replace the diskette drive cable connector to the diskette drive.

d. Connect the SCSI cable to the CD-ROM drive (or tape drive).

- e. **Replace the drive tray.**
See Section 9.2.6, “Replacing the RMA” on page 9-9.
3. **Connect the AC power cord.**
4. **Detach the wrist strap.**
5. **Replace the side access cover.**
See Section 7.3, “Replacing the Side Access Cover” on page 7-4.
6. **Power on the system unit.**
See Section 6.1, “Powering On the System Unit” on page 6-2.

8.5 EMI Filler Panels

To remove and replace the EMI filler panels from the front bezel or the drive tray, proceed as follows.

8.5.1 Removing an EMI Filler Panel

1. **Identify the EMI filler panel to be removed.**
2. **Remove an EMI filler panel as follows (FIGURE 8-5):**
 - a. **Remove the front bezel.**
 - b. **Use your finger to pop the EMI filler panel from the bezel.**
3. **Remove the drive tray drive.**
See Section 9.2.1, “Removing the RMA” on page 9-4.
4. **Use your fingers to pop the drive tray EMI filler panel from the drive tray (FIGURE 8-6).**

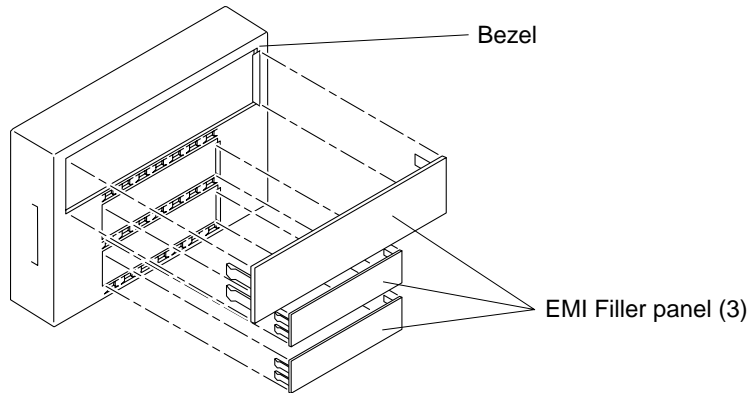

FIGURE 8-5 Removing and Replacing the Bezel EMI Filler Panel

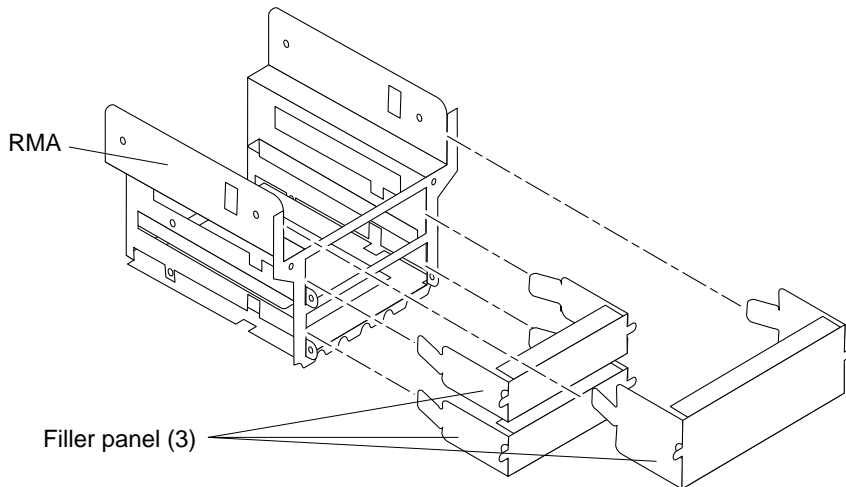

FIGURE 8-6 Removing and Replacing the RMA EMI Filler Panel

8.5.2 Replacing an EMI Filler Panel

- 1. Position and snap the EMI filler panel into the RMA (FIGURE 8-6).**
- 2. Replace the RMA.**
See Section 9.2.6, “Replacing the RMA” on page 9-9.
- 3. Position and snap the EMI filler panel into the bezel (FIGURE 8-5).**

8.6 Chassis Foot

To remove and replace a chassis foot, proceed as follows.

8.6.1 Removing the Foot

1. **Power off the system unit.**
See Section 6.2, “Powering Off the System Unit” on page 6-3.
2. **Lay the system unit in the service position.**
3. **Using a number 2 Phillips-head screwdriver, loosen the screw securing the foot to the chassis (FIGURE 8-7).**
4. **Remove the foot.**

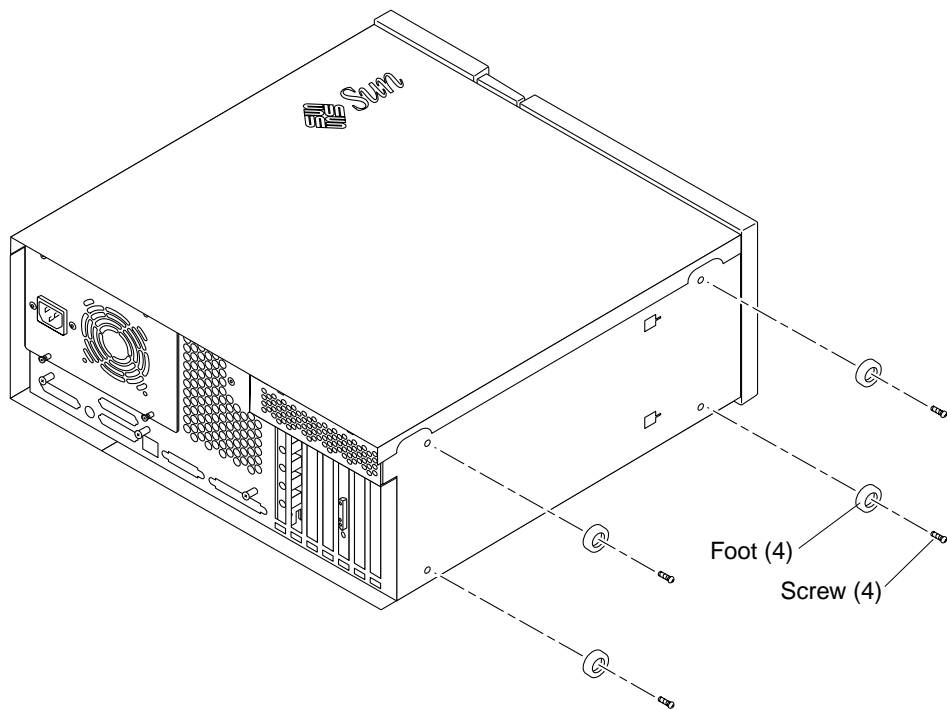

FIGURE 8-7 Removing and Replacing the Chassis Foot

8.6.2 Replacing the Foot

1. **Position the foot** (FIGURE 8-7).
2. **Using a number 2 Phillips-head screwdriver, tighten the screw securing the foot to the chassis.**
3. **Position the system unit in the operating position.**
4. **Power on the system unit.**
See Section 6.1, “Powering On the System Unit” on page 6-2.

8.7 Speaker Assembly

To remove and replace the speaker assembly, proceed as follows.

8.7.1 Removing the Speaker Assembly

1. **Power off the system unit.**
See Section 6.2, “Powering Off the System Unit” on page 6-3.
2. **Remove the side access cover.**
See Section 7.1, “Removing the Side Access Cover” on page 7-2.



Caution – Use proper ESD grounding techniques when handling components. Wear an antistatic wrist strap and use an ESD-protected mat. Store ESD-sensitive components in antistatic bags before placing them on any surface.

3. **Attach the wrist strap.**
See Section 7.2, “Attaching the Wrist Strap” on page 7-3.
4. **Remove the PCI fan assembly.**
See Section 8.2.1, “Removing the PCI Fan Assembly” on page 8-5.
5. **Disconnect the speaker cable from the motherboard** (FIGURE 8-8).
6. **Using a number 2 Phillips-head screwdriver, remove the screw securing the speaker assembly to the chassis.**
7. **Remove the speaker assembly.**

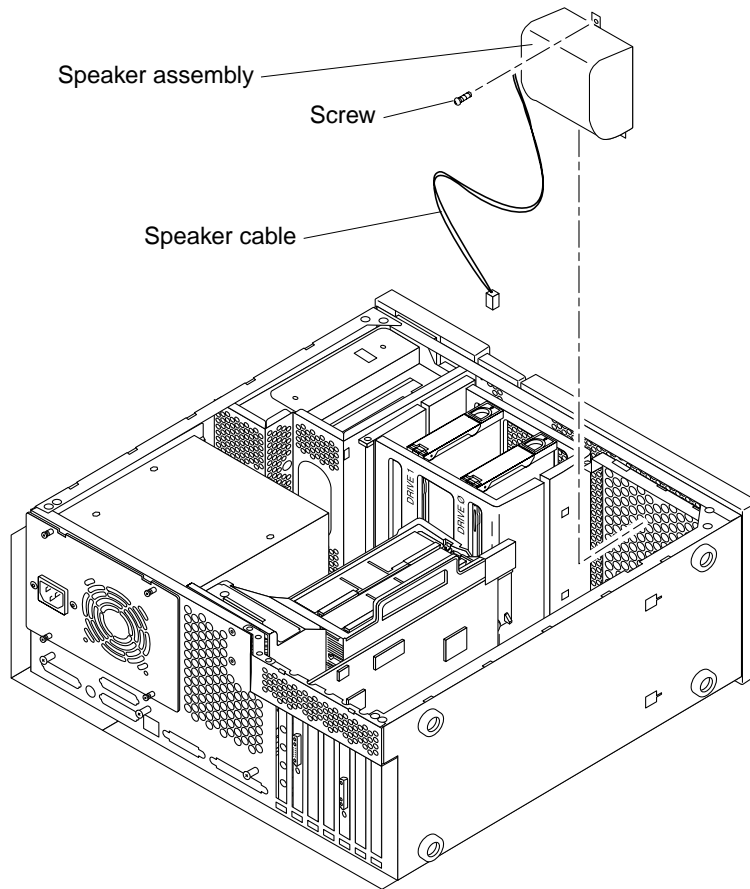

FIGURE 8-8 Removing and Replacing the Speaker Assembly

8.7.2 Replacing the Speaker Assembly



Caution – Use proper ESD grounding techniques when handling components. Wear an antistatic wrist strap and use an ESD-protected mat. Store ESD-sensitive components in antistatic bags before placing them on any surface.

1. **Position the speaker assembly in the chassis** (FIGURE 8-8).
2. **Connect the speaker cable to the motherboard.**
3. **Using a number 2 Phillips-head screwdriver, replace the screw securing the speaker assembly to the chassis.**

4. Replace the PCI fan assembly.

See Section 8.2.2, “Replacing the PCI Fan Assembly” on page 8-6.

5. Connect the AC power cord.

6. Detach the wrist strap.

7. Replace the side access cover.

See Section 7.3, “Replacing the Side Access Cover” on page 7-4.

8. Power on the system unit.

See Section 6.1, “Powering On the System Unit” on page 6-2.

8.8 DC Switch Assembly

To remove and replace the DC switch assembly, proceed as follows.

8.8.1 Removing the DC Switch Assembly



Caution – Use proper ESD grounding techniques when handling components. Wear an antistatic wrist strap and use an ESD-protected mat. Store ESD-sensitive components in antistatic bags before placing them on any surface.



Caution – The DC switch assembly removal procedure is a complex procedure. It is recommended that a qualified field service representative perform this procedure.

1. Power off the system unit.

See Section 6.2, “Powering Off the System Unit” on page 6-3.



Caution – Pressing the front panel power switch does not remove all power from the system unit; a trickle voltage remains in the power supply. To remove all power from the system unit, disconnect the AC power cord.

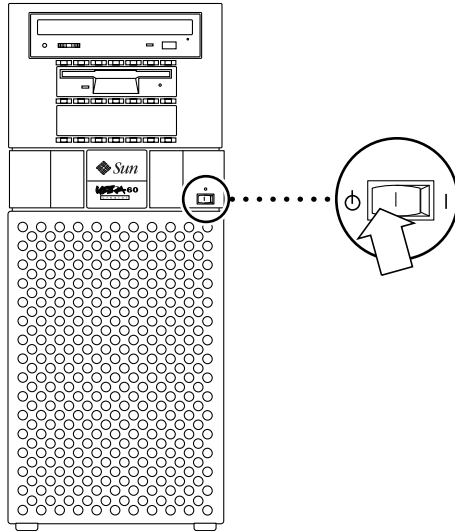

FIGURE 8-9 System Unit Power-Off (Front Panel)



Caution – Disconnect the AC power cord prior to servicing system components.

2. **Disconnect the lock block** (FIGURE 8-2).

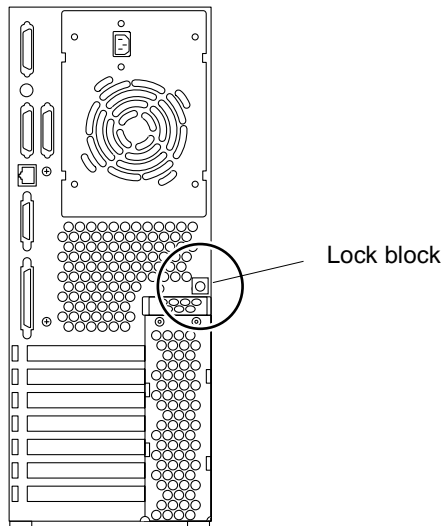

FIGURE 8-10 Lock Block Location

3. Remove the side access cover.

See Section 7.1, “Removing the Side Access Cover” on page 7-2.



Caution – Use proper ESD grounding techniques when handling components. Wear an antistatic wrist strap and use an ESD-protected mat. Store ESD-sensitive components in antistatic bags before placing them on any surface.

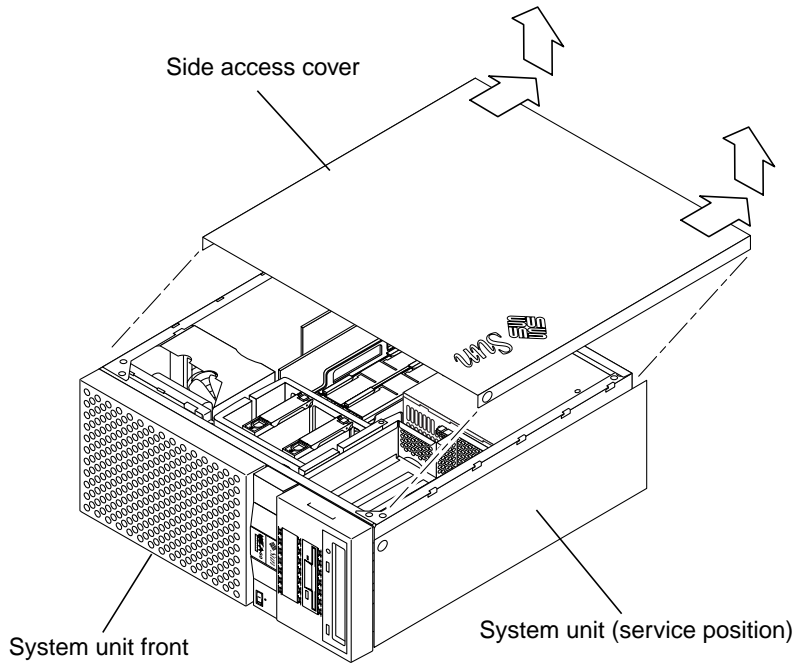

FIGURE 8-11 Removing the Side Access Cover

4. Attach the wrist strap.

See Section 7.2, “Attaching the Wrist Strap” on page 7-3.

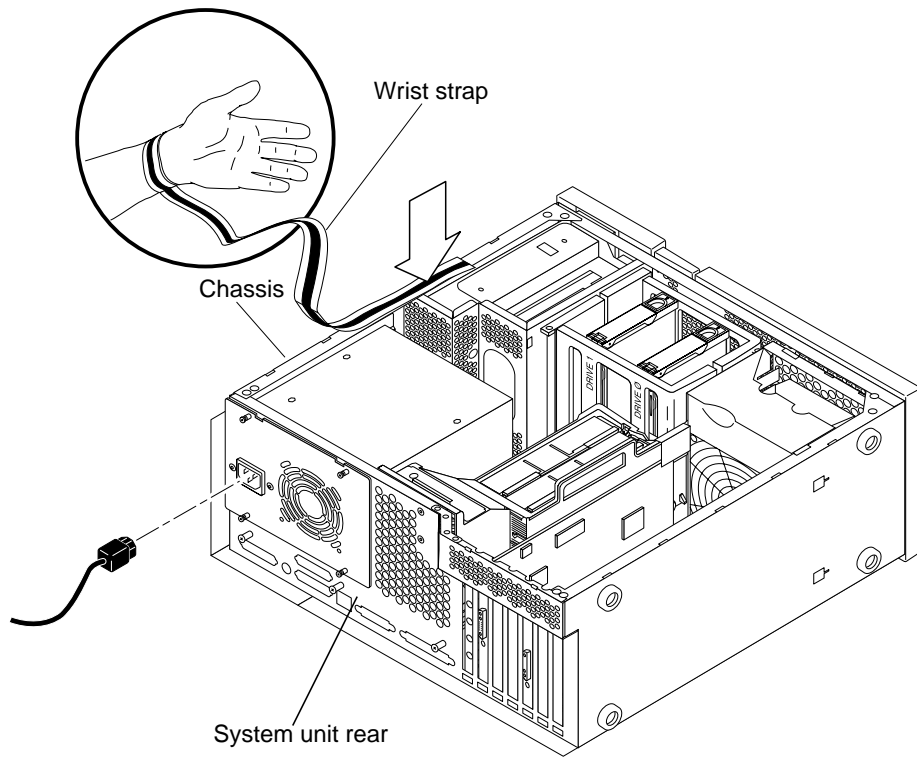

FIGURE 8-12 Attaching the Wrist Strap to the Chassis

- 5. Remove any long PCI cards and UPA graphics cards (FIGURE 8-5 and FIGURE 8-6):**
See Section 10.3.1, “Removing a PCI Card” on page 10-7.

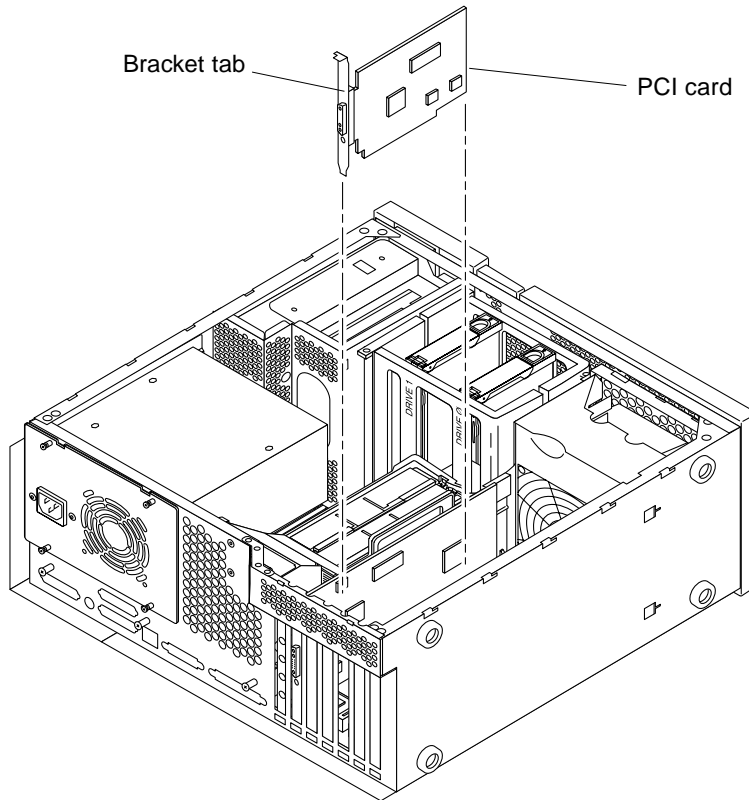

FIGURE 8-13 Removing and Replacing a PCI Card

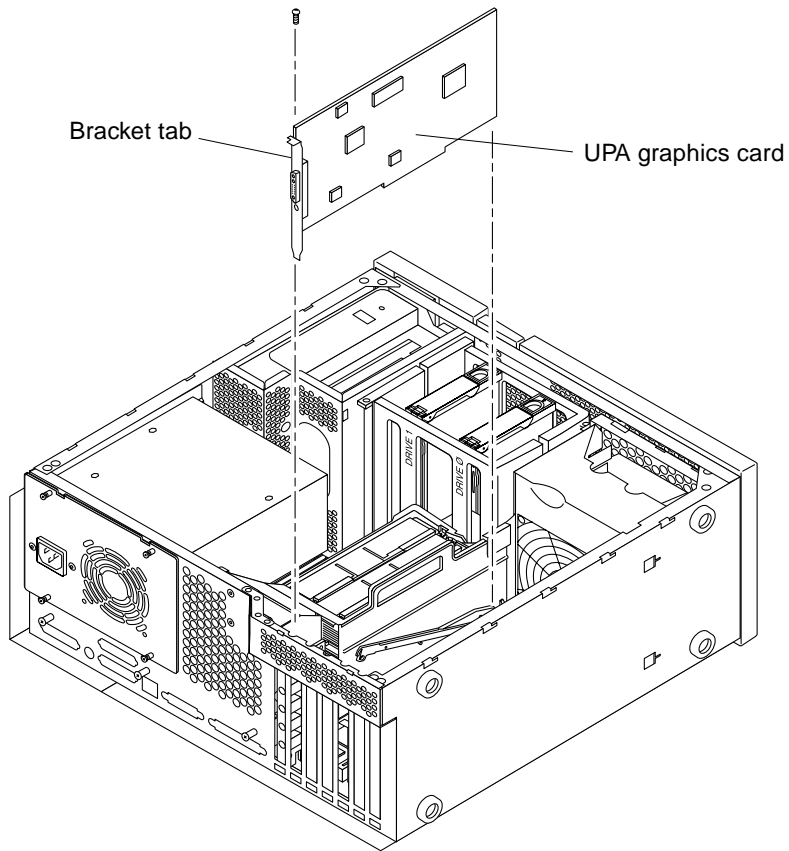

FIGURE 8-14 Removing and Replacing a UPA Graphics Card

6. Remove the PCI fan assembly (FIGURE 8-7):

See Section 8.2.1, “Removing the PCI Fan Assembly” on page 8-5.

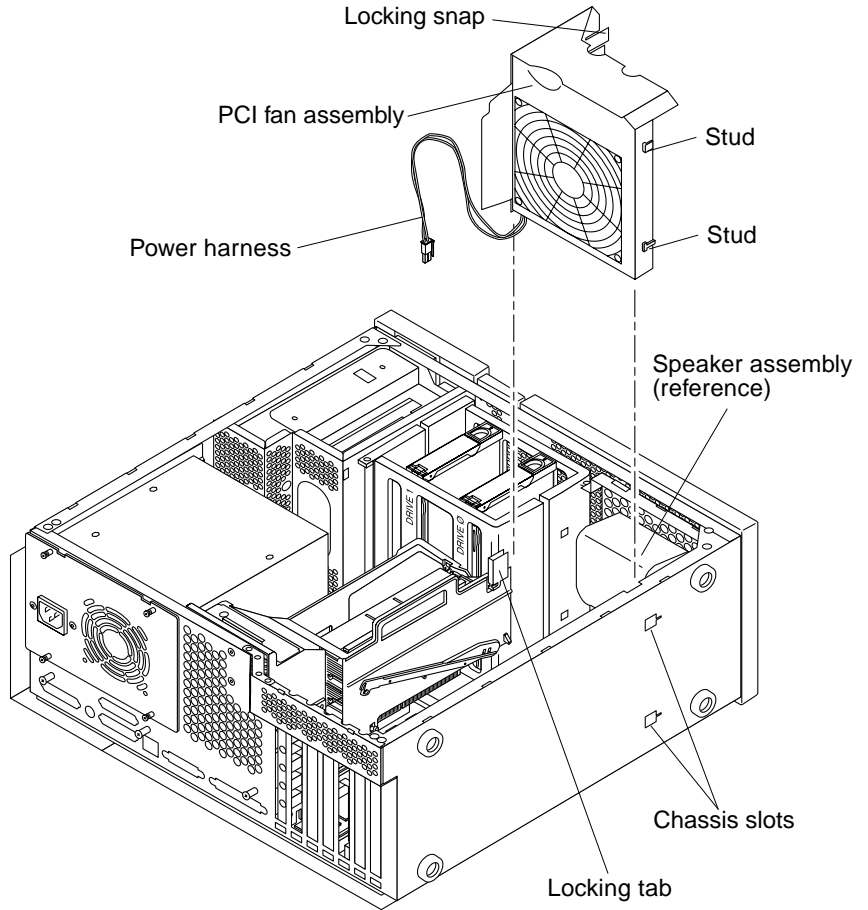

FIGURE 8-15 Removing and Replacing the PCI Fan Assembly

7. Remove the hard drive(s) (FIGURE 8-8):

See Section 9.1.1, “Removing a Hard Drive” on page 9-2.

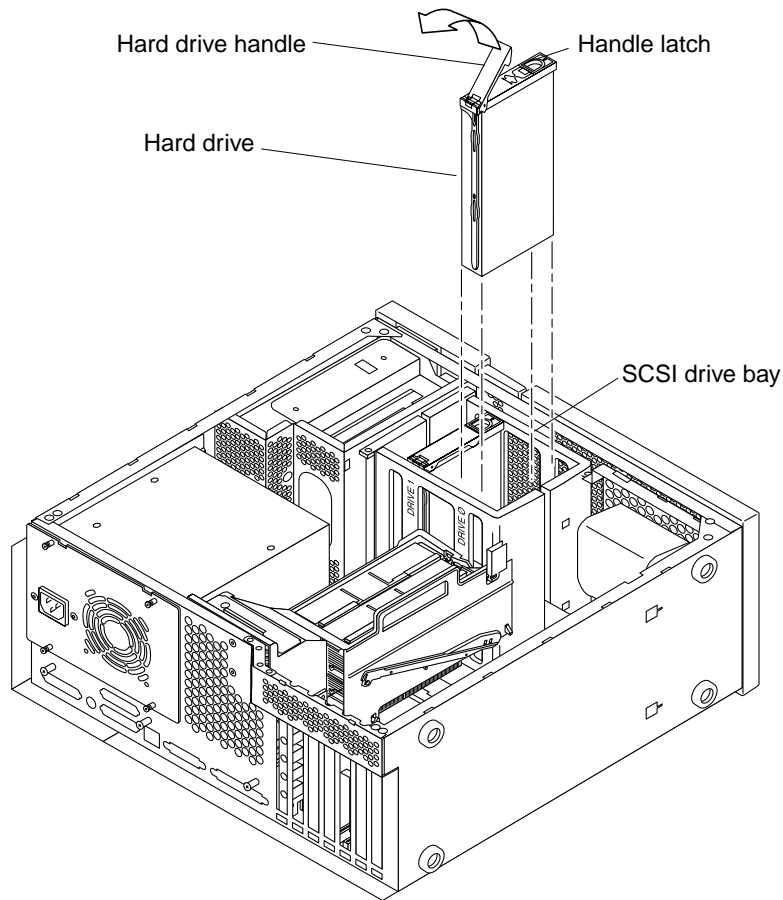

FIGURE 8-16 Removing and Replacing a Hard Drive



Caution – Prior to removing the SCSI drive bay, ensure that all necessary cables have been removed and that all cables are clear of the chassis area surrounding the drive bay area.

8. Remove the SCSI drive bay (FIGURE 8-17):

a. Disconnect the SCSI cables.

Note – For better access to the SCSI cable terminator board connector, partially remove the RMA (removal media assembly). To partially remove the RMA, refer to *Section 9.2* in the *Sun Ultra 60 Service Manual*.

b. Disconnect the peripheral power cable.

c. Remove the peripheral power cable from the cable routing clips.

d. Remove the diskette drive cable from the plastic spring clips installed adjacent to the drive bay.

e. Feed the peripheral power cable through the chassis opening.

f. Using a number 2 Phillips-head screwdriver, remove the screws securing the SCSI drive bay to the chassis.

g. Lift the SCSI drive bay out of the chassis.

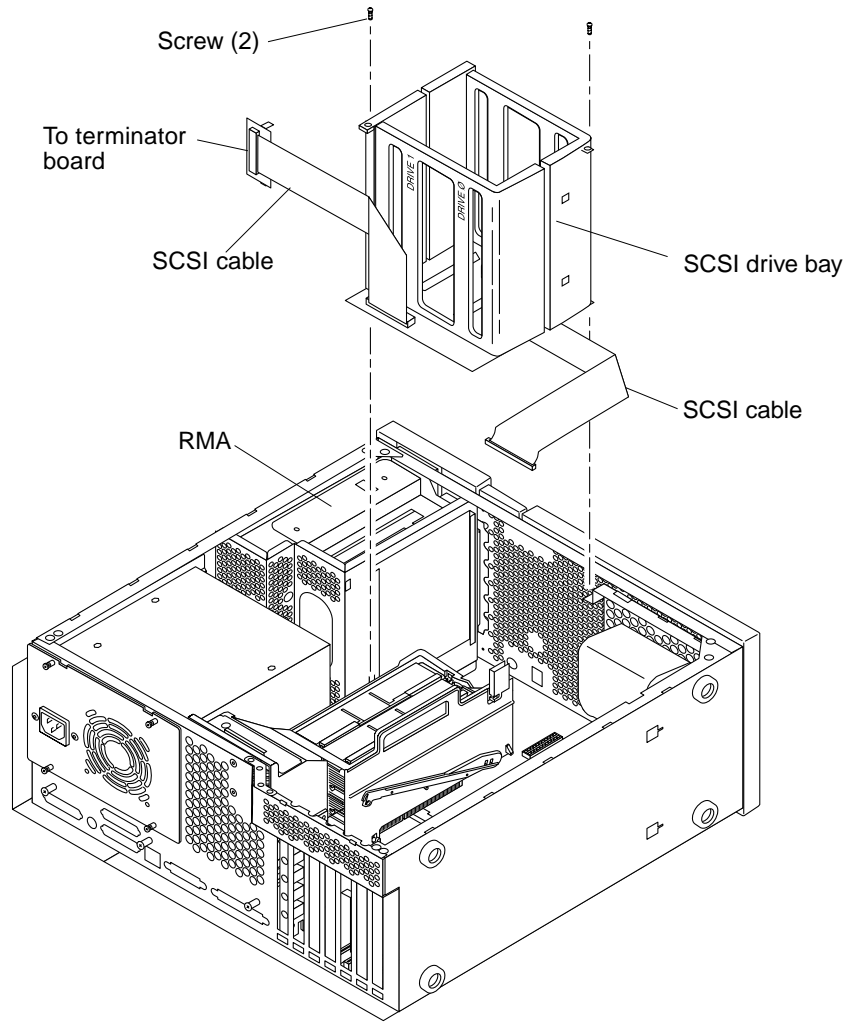

FIGURE 8-17 Removing and Replacing the SCSI Drive Bay

- 9. Disconnect the DC switch assembly power connector from motherboard connector J3504 (FIGURE 8-18).**

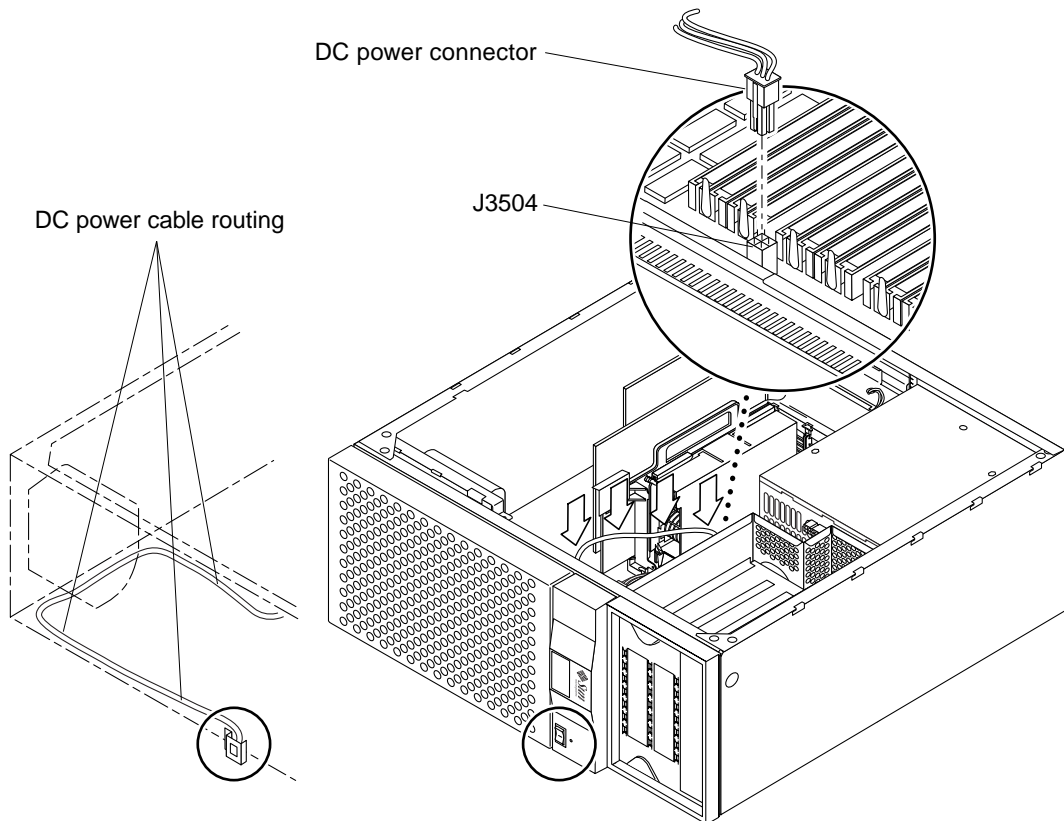

FIGURE 8-18 DC Switch Assembly Cable Routing

- 10. Remove the DC switch assembly power cable from the cable routing clips.**
- 11. Remove the front panel (FIGURE 8-19):**
- Remove the front panel bezel.**
 - Remove the front panel nameplate and light pipe.**
 - Using a number 2 Phillips-head screwdriver, remove the four screws securing the front panel to the chassis.**
 - Remove the front panel from the chassis.**

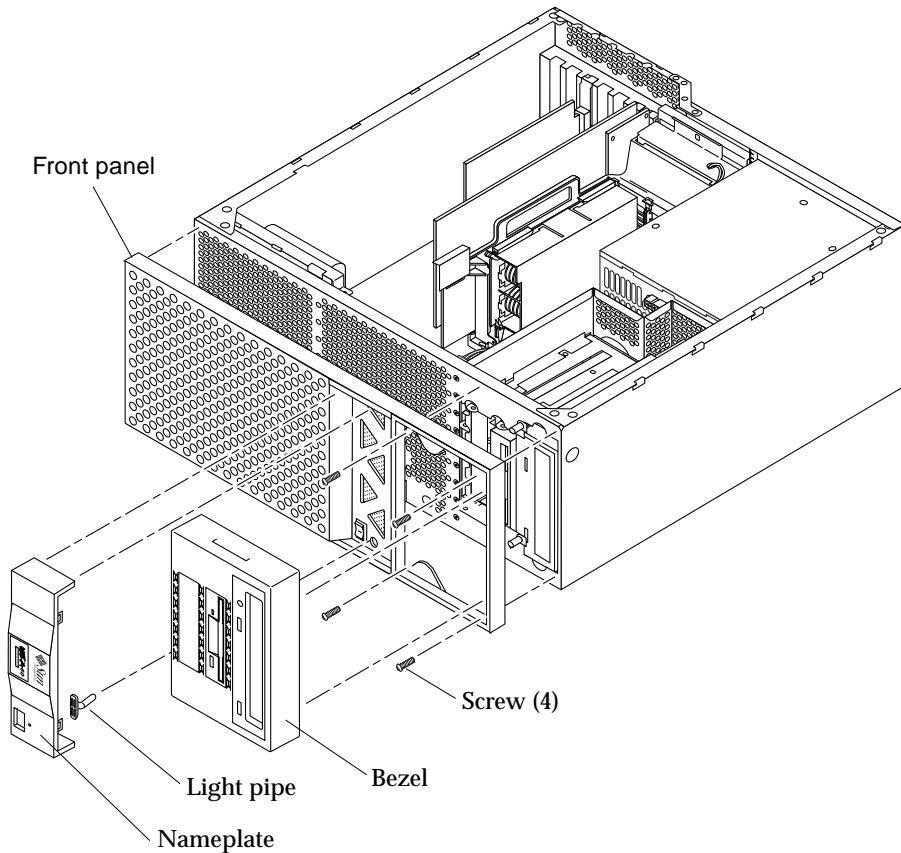

FIGURE 8-19 Removing and Replacing the Front Panel

12. Remove the DC switch assembly from the front panel (FIGURE 8-20):
 - a. Accessing the rear of the front panel and using a small flat-blade screwdriver, press the detent tab on one side of the DC switch assembly while pushing the switch toward the front of the front panel.
 - b. Repeat Step a for the other side of the DC switch assembly.
 - c. Continue pressing the detent tab on alternate sides and pushing the DC switch assembly toward the front until the DC switch assembly can be removed from the housing.
 - d. Remove the DC switch assembly from the front panel.

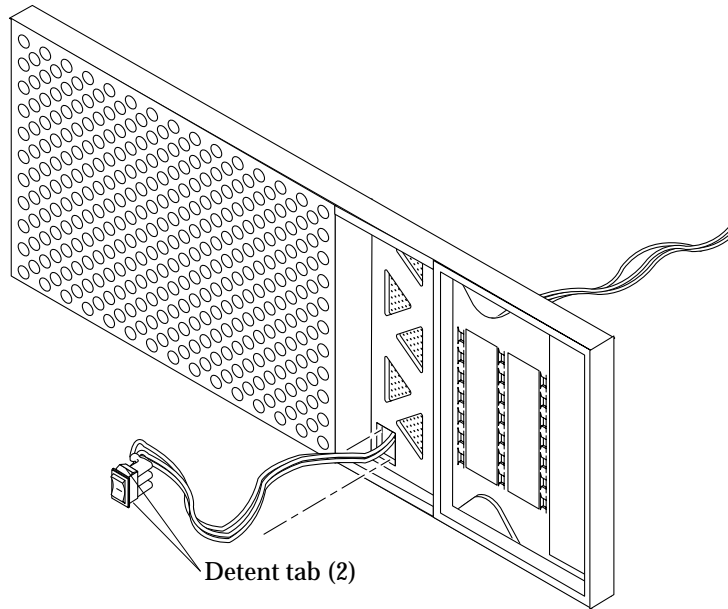

FIGURE 8-20 Removing and Replacing the Front Panel DC Switch Assembly

8.8.2 Replacing the DC Switch Assembly

This procedure revises the DC switch assembly replacement procedure found in the *Sun Ultra 60 Service Manual*, part number 805-1709.



Caution – Use proper ESD grounding techniques when handling components. Wear an antistatic wrist strap and use an ESD-protected mat. Store ESD-sensitive components in antistatic bags before placing them on any surface.



Caution – The DC switch assembly replacement procedure is a complex procedure. It is recommended that a qualified field service representative perform this procedure.



Caution – When replacing the DC switch assembly, ensure that the DC switch spade connectors are pointed towards the bottom of the case.

1. Replace the DC switch assembly through the front of the front panel (FIGURE 8-20):
 - a. Feed the DC switch assembly power cable through the front of the front panel.
 - b. Using a small flat-blade screwdriver, press the detent tab on one side of the DC switch assembly while pushing the switch into the front panel from the front.
 - c. Repeat Step b for the other side of the DC switch assembly.
 - d. Continue pressing the detent tab on alternate sides and pushing the DC switch assembly into the front panel until the DC switch assembly locks into the front panel housing.
2. Replace the front panel (FIGURE 8-19):
 - a. Replace the nameplate onto the front panel, ensuring that the light pipe tabs are oriented with the nameplate cutouts.
 - b. Feed the DC switch assembly power cable through the chassis front (FIGURE 8-18).
 - c. Position the front panel onto the chassis. Using a number 2 Phillips-head screwdriver, replace the four screws securing the front panel to the chassis.
 - d. Replace the front panel bezel (not illustrated).
3. Route the DC power cable along the chassis front and side. Secure the power cable in place using the cable routing clips (FIGURE 8-18).
4. Connect the DC switch assembly power connector to motherboard connector J3504 (FIGURE 8-18).
5. Replace the SCSI drive bay (FIGURE 8-17):



Caution – Prior to replacing the SCSI drive bay, ensure that all cables are clear of the drive bay area in the chassis.

Note – Hooks at the drive bay base must lock into the bottom slots of the chassis.

- a. Slide the SCSI drive bay into the chassis.



Caution – When replacing the screws that secure the SCSI drive bay to the chassis, pay particular attention not to allow a screw to fall into the chassis.

- b. Using a number 2 Phillips-head screwdriver, replace the screws securing the SCSI drive bay to the chassis.

- c. **Connect the SCSI cables.**
 - d. **If necessary, replace the RMA (refer to *Section 9.2 in the Sun Ultra 60 Service Manual*).**
 - e. **Feed the peripheral power cable through the chassis opening.**
 - f. **Route the diskette drive cable through the plastic spring clips installed adjacent to the drive bay.**
 - g. **Route the peripheral power cable through the cable routing clips.**
 - h. **Connect the peripheral power cable.**
- 6. Replace the hard drive(s) (FIGURE 8-16):**
See Section 9.1.2, “Replacing a Hard Drive” on page 9-3.



Caution – Ensure that the hard drive is firmly seated into the system unit SCSI connector.

- 7. Replace the PCI fan assembly (FIGURE 8-15):**
- a. **Lower the PCI fan assembly into the chassis and move it over and toward the chassis front.**
 - b. **Align the PCI fan assembly studs with the chassis slots and engage.**
 - c. **Press the locking snap and engage to lock the fan assembly in place.**
 - d. **Connect the PCI fan power harness connector to the motherboard.**
- 8. Replace any long PCI cards or UPA graphics cards (FIGURE 8-13 and FIGURE 8-14).**
See Section 10.3.2, “Replacing a PCI Card” on page 10-9.
- 9. Connect the AC power cord.**
- 10. Detach the wrist strap.**
- 11. Replace the side access cover (FIGURE 8-21).**
See Section 7.3, “Replacing the Side Access Cover” on page 7-4.

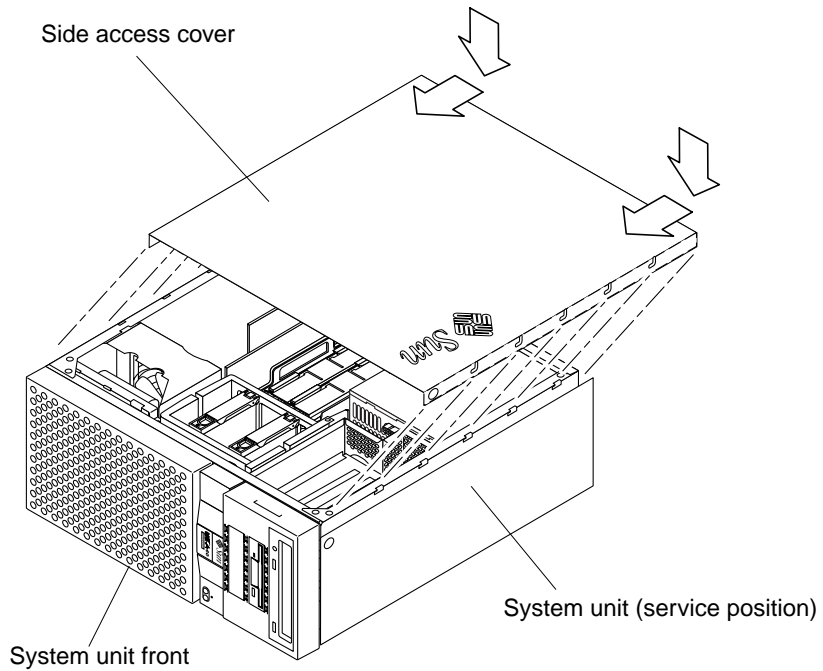

FIGURE 8-21 Replacing the Side Access Cover

- 12. Connect the lock block (FIGURE 8-10).**
- 13. Position the system unit in the operating position.**
- 14. Reconnect cables to any peripheral equipment.**
- 15. Turn on the power to the monitor.**
- 16. Power on the system unit.**

See Section 6.1, "Powering On the System Unit" on page 6-2.

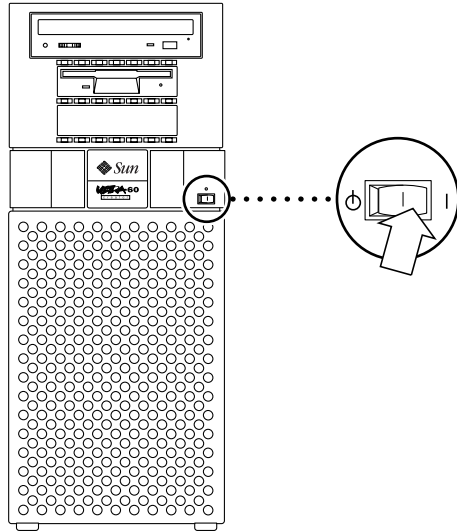

FIGURE 8-22 System Unit Power-On (Front Panel)

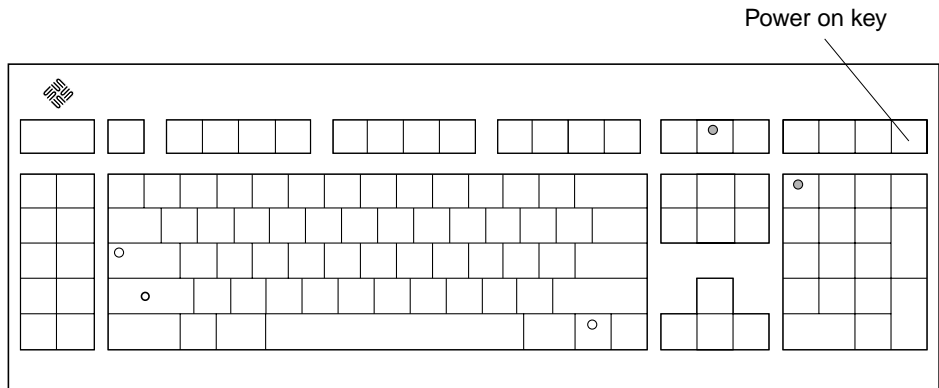

FIGURE 8-23 Sun Type-5 Keyboard

8.9 CPU Fan Assembly

To remove and replace the CPU fan assembly, proceed as follows.

8.9.1 Removing the CPU Fan Assembly

1. Power off the system unit.

See Section 6.2, “Powering Off the System Unit” on page 6-3.

2. Remove the side access cover.

See Section 7.1, “Removing the Side Access Cover” on page 7-2.



Caution – Use proper ESD grounding techniques when handling components. Wear an antistatic wrist strap and use an ESD-protected mat. Store ESD-sensitive components in antistatic bags before placing them on any surface.

3. Attach the wrist strap.

See Section 7.2, “Attaching the Wrist Strap” on page 7-3.

4. Disconnect the CPU fan as follows (FIGURE 8-24):

- a. Disconnect the CPU fan assembly power cable from the motherboard connector J2601. Unroute the CPU fan assembly power cable from the five cable clips.**
- b. Using a number 2 Phillips-head screwdriver, press the snap catch to release the fan assembly from the shroud assembly.**
- c. Using the metal handle, lift the fan assembly from the shroud assembly.**

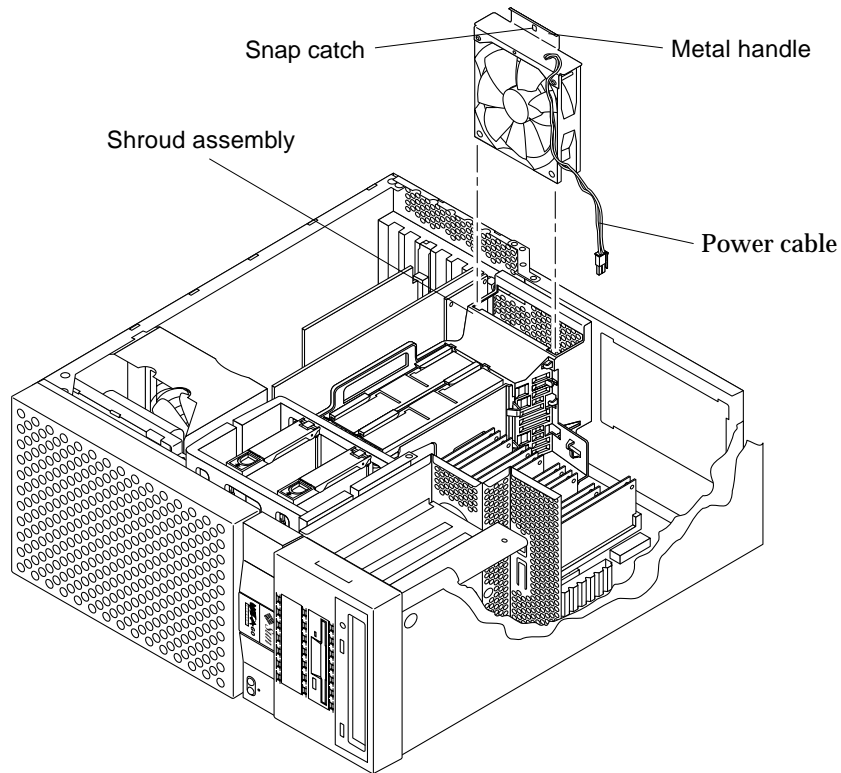

FIGURE 8-24 Removing and Replacing the CPU Fan Assembly

8.9.2 Replacing the CPU Fan Assembly



Caution – Use proper ESD grounding techniques when handling components. Wear an antistatic wrist strap and use an ESD-protected mat. Store ESD-sensitive components in antistatic bags before placing them on any surface.

1. **Connect the CPU fan assembly as follows (FIGURE 8-24):**
 - a. **Using the metal handle, insert the fan assembly into the shroud assembly, firmly compressing the foam until the catch snap activates into the square opening.**
 - b. **Route the CPU fan assembly power cable through the five cable clips. Connect the CPU fan assembly power cable to the motherboard connector J2601.**

2. **Connect the AC power cord.**
3. **Detach the wrist strap.**
4. **Replace the side access cover.**
See Section 7.3, “Replacing the Side Access Cover” on page 7-4.
5. **Power on the system unit.**
See Section 6.1, “Powering On the System Unit” on page 6-2.

8.10 Shroud Assembly

To remove and replace the shroud assembly, proceed as follows.

8.10.1 Removing the Shroud Assembly

1. **Power off the system unit.**
See Section 6.2, “Powering Off the System Unit” on page 6-3.
2. **Remove the side access cover.**
See Section 7.1, “Removing the Side Access Cover” on page 7-2.



Caution – Use proper ESD grounding techniques when handling components. Wear an antistatic wrist strap and use an ESD-protected mat. Store ESD-sensitive components in antistatic bags before placing them on any surface.

3. **Attach the wrist strap.**
See Section 7.2, “Attaching the Wrist Strap” on page 7-3.
4. **Remove the CPU modules.**
See Section 10.1.2, “Removing the CPU Module” on page 10-2.
5. **Disconnect the shroud assembly as follows (FIGURE 8-25):**
 - a. **Disconnect the CPU fan assembly power cable from the motherboard connector J2601.**
 - b. **Using a number 2 Phillips-head screwdriver, loosen the captive screws securing the shroud assembly to the motherboard until the screws pop up.**
 - c. **Lift the locking lever to unlock the shroud assembly from the motherboard.**

6. Remove the shroud assembly from the motherboard.

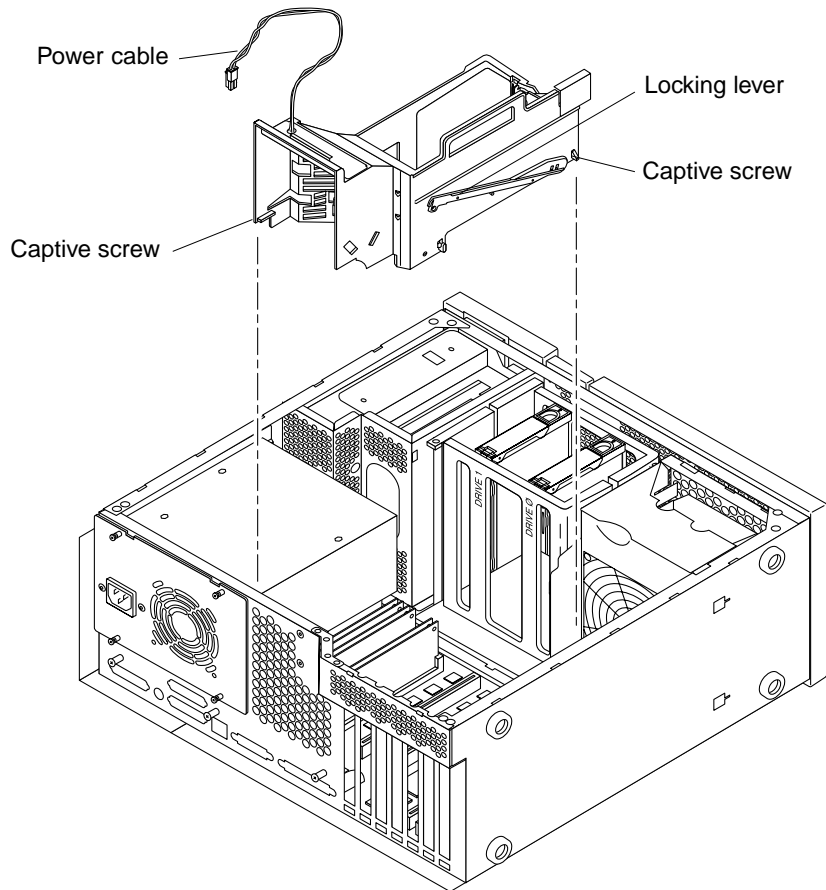

FIGURE 8-25 Removing and Replacing the Shroud Assembly

8.10.2 Replacing the Shroud Assembly



Caution – Use proper ESD grounding techniques when handling components. Wear an antistatic wrist strap and use an ESD-protected mat. Store ESD-sensitive components in antistatic bags before placing them on any surface.

- 1. Position the shroud assembly onto the motherboard.**
- 2. Connect the shroud assembly as follows (FIGURE 8-25):**

- a. **Lower the locking lever to lock the shroud assembly to the motherboard.**
 - b. **Using a number 2 Phillips-head screwdriver, tighten the captive screws securing the shroud assembly to the motherboard.**
 - c. **Connect the power cable to the motherboard connector J2601.**
3. **Replace the CPU modules.**
See Section 10.1.3, “Replacing the CPU Module” on page 10-4.
 4. **Connect the AC power cord.**
 5. **Detach the wrist strap.**
 6. **Replace the side access cover.**
See Section 7.3, “Replacing the Side Access Cover” on page 7-4.
 7. **Power on the system unit.**
See Section 6.1, “Powering On the System Unit” on page 6-2.

Storage Devices

This chapter describes how to remove and replace the Ultra 60 storage devices.

This chapter contains the following topics:

- Hard Drive—page 9-2
- Removable Media Assembly Drive—page 9-4

Note – The actions required to remove and replace the major subassemblies are also illustrated with photographs and audio/visual instructions on the *Sun Ultra 60 ShowMe How Multimedia Documentation*, part number 704-5886.

9.1 Hard Drive

To remove and replace a hard drive, proceed as follows.

9.1.1 Removing a Hard Drive

1. Power off the system unit.

See Section 6.2, “Powering Off the System Unit” on page 6-3.

2. Remove the side access cover.

See Section 7.1, “Removing the Side Access Cover” on page 7-2.



Caution – Use proper ESD grounding techniques when handling components. Wear an antistatic wrist strap and use an ESD-protected mat. Store ESD-sensitive components in antistatic bags before placing them on any surface.

3. Attach the wrist strap.

See Section 7.2, “Attaching the Wrist Strap” on page 7-3.

4. Remove the hard drive as follows (FIGURE 9-1):

a. Push the handle latch to open the hard drive handle.

b. Extend the hard drive handle to disconnect the hard drive from the system unit.

c. Holding the drive handle, remove the hard drive from the drive bay.

5. Place the hard drive on an antistatic mat.

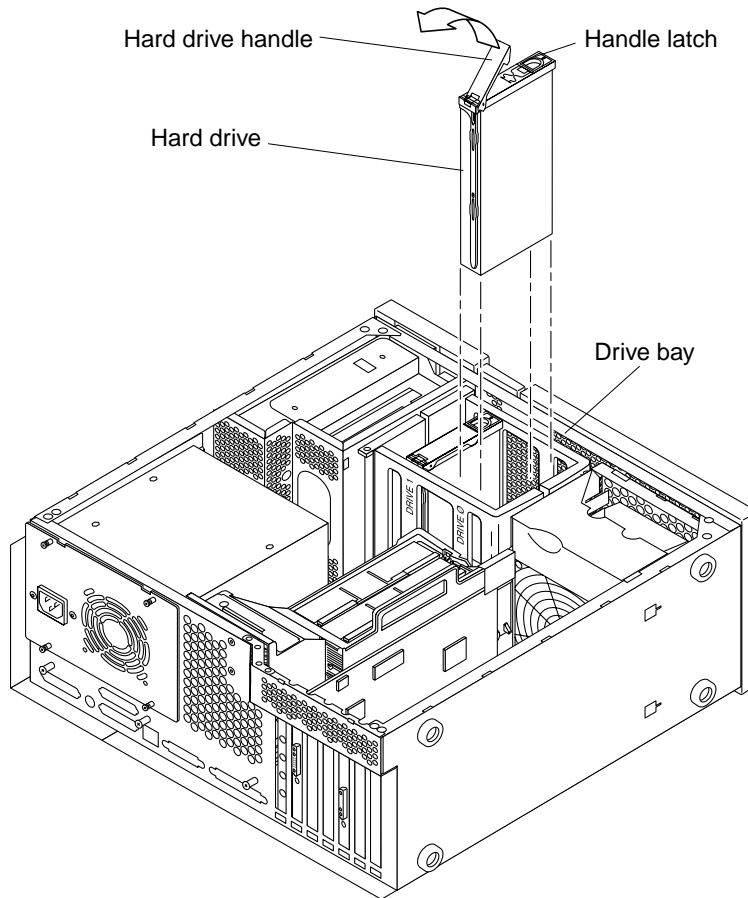

FIGURE 9-1 Removing and Replacing a Hard Drive

9.1.2 Replacing a Hard Drive



Caution – Use proper ESD grounding techniques when handling components. Wear an antistatic wrist strap and use an ESD-protected mat. Store ESD-sensitive components in antistatic bags before placing them on any surface.

1. **Replace the hard drive as follows (FIGURE 9-1):**
 - a. **Holding the drive handle, insert the hard drive into the drive bay.**
 - b. **Push the front of the hard drive to connect it to the SCSI bus.**

- c. **Close the hard drive handle to lock the hard drive into the system unit.**
2. **Connect the AC power cord.**
3. **Detach the wrist strap.**
4. **Replace the side access cover.**
See Section 7.3, “Replacing the Side Access Cover” on page 7-4.
5. **Power-on the system unit.**
See Section 6.1, “Powering On the System Unit” on page 6-2.

9.2 Removable Media Assembly Drive

To remove and replace a removable media assembly (RMA) drive, it is necessary to remove and replace the RMA. To remove and replace the RMA and an RMA drive, refer to FIGURE 9-2 and FIGURE 9-3 and proceed as follows.

Note – An RMA drive can include a CD-ROM drive, a 4-mm or 8-mm tape drive, or any offered X-Option, such as a second diskette drive or a PCI-connected device.

Note – If there are no drives installed into the RMA, only the SCSI cable should be routed into the upper drive bay. Attach the SCSI cable into the clip affixed on the rear wall of the RMA.

9.2.1 Removing the RMA

1. **Power off the system unit.**
See Section 6.2, “Powering Off the System Unit” on page 6-3.
2. **Remove the side access cover.**
See Section 7.1, “Removing the Side Access Cover” on page 7-2.



Caution – Use proper ESD grounding techniques when handling components. Wear an antistatic wrist strap and use an ESD-protected mat. Store ESD-sensitive components in antistatic bags before placing them on any surface.

3. Attach the wrist strap.

See Section 7.2, “Attaching the Wrist Strap” on page 7-3.

4. Remove the RMA as follows (FIGURE 9-2):

a. Remove the front bezel.

b. Using a number 2 Phillips-head screwdriver, loosen the captive screws securing the RMA to the chassis.

c. Partially remove the RMA from the chassis.

d. Disconnect the peripheral cables and the power cables from the drives (not illustrated).

e. Remove the RMA from the chassis.

5. Place the RMA on an antistatic mat.

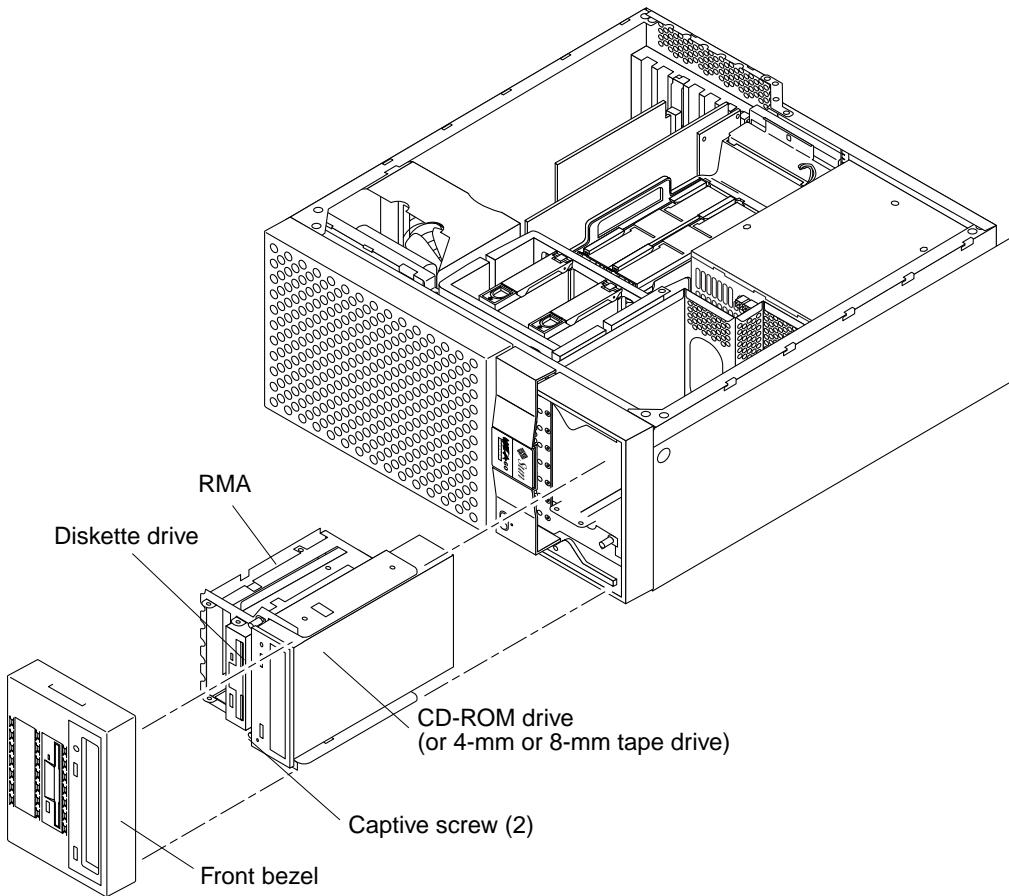

FIGURE 9-2 Removing and Replacing a RMA Drive (Part 1 of 2)

9.2.2 Removing the CD-ROM Drive or Any X-Option Tape Drive



Caution – Use proper ESD grounding techniques when handling components. Wear an antistatic wrist strap and use an ESD-protected mat. Store ESD-sensitive components in antistatic bags before placing them on any surface.

1. Position the RMA on a flat surface so that the CD-ROM drive or tape drive is flat (FIGURE 9-3).

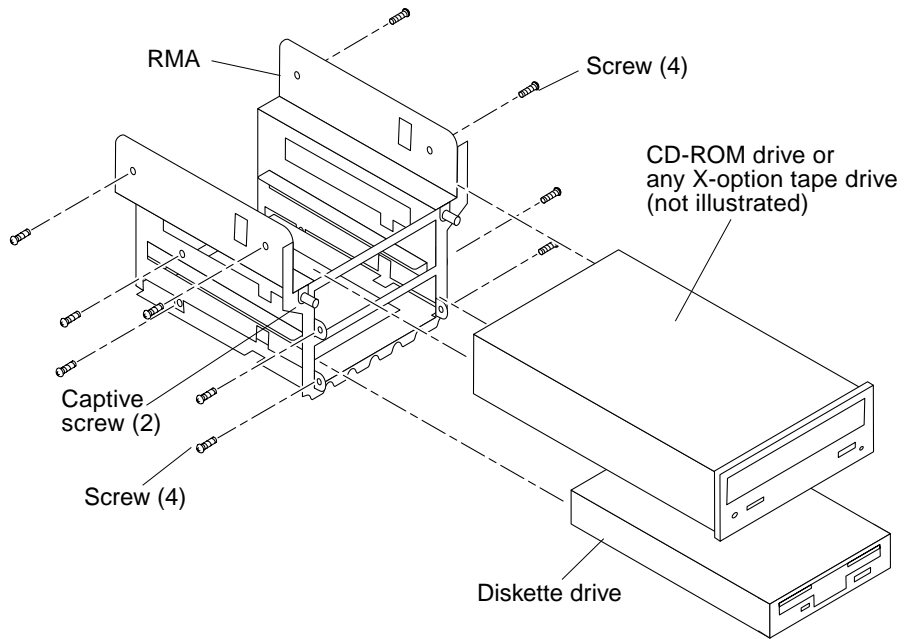

FIGURE 9-3 Removing and Replacing a RMA Drive (Part 2 of 2)

- 2. Using a number 2 Phillips-head screwdriver, remove the four screws securing the CD-ROM drive or tape drive to the RMA.**
- 3. Remove the CD-ROM drive or tape drive and place it on an antistatic mat.**

9.2.3 Replacing the CD-ROM Drive or Any X-Option Tape Drive

Note – If *installing* a CD-ROM drive or any X-option tape drive (verses *replacing*), ensure that the peripheral power cable and all data cables are properly routed through the clips adjacent to the drive bay. Route the SCSI data cable through both plastic spring clips installed adjacent to the hard disk drive bay.



Caution – Use proper ESD grounding techniques when handling components. Wear an antistatic wrist strap and use an ESD-protected mat. Store ESD-sensitive components in antistatic bags before placing them on any surface.

1. **Position the CD-ROM drive or tape drive into the RMA (FIGURE 9-3).**
2. **Using a number 2 Phillips-head screwdriver, replace the four screws securing the CD-ROM drive or tape drive to the RMA.**
3. **Replace the RMA.**

See Section 9.2.6, “Replacing the RMA” on page 9-9.

9.2.4 Removing the Diskette Drive



Caution – Use proper ESD grounding techniques when handling components. Wear an antistatic wrist strap and use an ESD-protected mat. Store ESD-sensitive components in antistatic bags before placing them on any surface.

1. **Position the diskette drive.**
2. **Using a number 2 Phillips-head screwdriver, remove the four screws securing the diskette drive to the RMA (FIGURE 9-3).**
3. **Remove the diskette drive and place it on an antistatic mat.**

9.2.5 Replacing the Diskette Drive

Note – If *installing* a diskette drive (verses *replacing*), ensure that the peripheral power cable and all data cables are properly routed through the clips adjacent to the drive bay. Route the diskette drive cable through both plastic spring clips installed adjacent to the hard disk drive bay.



Caution – Use proper ESD grounding techniques when handling components. Wear an antistatic wrist strap and use an ESD-protected mat. Store ESD-sensitive components in antistatic bags before placing them on any surface.

1. **Position the diskette drive into the RMA** (FIGURE 9-3).
2. **Using a number 2 Phillips-head screwdriver, replace the four screws securing the diskette drive to the RMA.**
3. **Replace the RMA.**
See Section 9.2.6, “Replacing the RMA” on page 9-9.

9.2.6 Replacing the RMA



Caution – Use proper ESD grounding techniques when handling components. Wear an antistatic wrist strap and use an ESD-protected mat. Store ESD-sensitive components in antistatic bags before placing them on any surface.

1. **Replace the RMA as follows** (FIGURE 9-2):
 - a. **Position the RMA into the chassis, connect the rear cable connectors as required.**
 - b. **Using a number 2 Phillips-head screwdriver, tighten the captive screws securing the RMA to the chassis.**
2. **Replace the front bezel.**
3. **Connect the AC power cord.**
4. **Detach the wrist strap.**

5. Replace the side access cover.

See Section 7.3, “Replacing the Side Access Cover” on page 7-4.

6. Power on the system unit.

See Section 6.1, “Powering On the System Unit” on page 6-2.

Motherboard and Component Replacement

This chapter describes how to remove and replace the Ultra 60 motherboard and motherboard components.

This chapter contains the following topics:

- CPU Module—page 10-2
- NVRAM/TOD—page 10-5
- PCI Card—page 10-7
- UPA Graphics Card—page 10-10
- DIMM—page 10-12
- Audio Card—page 10-16
- Motherboard—page 10-19

Note – The actions required to remove and replace the major subassemblies are also illustrated with photographs and audio/visual instructions on the *Sun Ultra 60 ShowMe How Multimedia Documentation*, part number 704-5886.

10.1 CPU Module

To remove and replace the CPU module, proceed as follows.

10.1.1 Special Considerations for Systems With 450 MHz CPU Modules

If you plan on installing either the Solaris™ 2.5.1 or Solaris 2.6 operating environment, you must install it using the *Operating Environment Installation CD* included with your new system. During the installation process, this CD installs certain software upgrade patches that support these Solaris releases running at the 450 MHz CPU speed.

These patches are not required if you are using Solaris 7 or later software.

The system's OpenBoot PROM revision level must be 3.17 Version 0, or later, to run a 450 MHz CPU module. The OpenBoot PROM revision level is displayed in the banner at the top of the screen when you boot the system, or from the OpenBoot prompt you can display the banner by typing.

```
ok banner
```

For installation instructions, refer to the CD insert included with the CD.

10.1.2 Removing the CPU Module

1. Power off the system unit.

See Section 6.2, "Powering Off the System Unit" on page 6-3.

2. Remove the side access cover.

See Section 7.1, "Removing the Side Access Cover" on page 7-2.



Caution – Use proper ESD grounding techniques when handling components. Wear an antistatic wrist strap and use an ESD-protected mat. Store ESD-sensitive components in antistatic bags before placing them on any surface.

3. Attach a wrist strap.

See Section 7.2, “Attaching the Wrist Strap” on page 7-3.

4. Remove the CPU module as follows (FIGURE 10-1):

- a. Using the thumbs of both hands, simultaneously lift the two levers on the CPU module upward and to the side to approximately 135 degrees.
- b. Lift the CPU module upward until it clears the system unit chassis.

5. Place the CPU module on an antistatic mat.

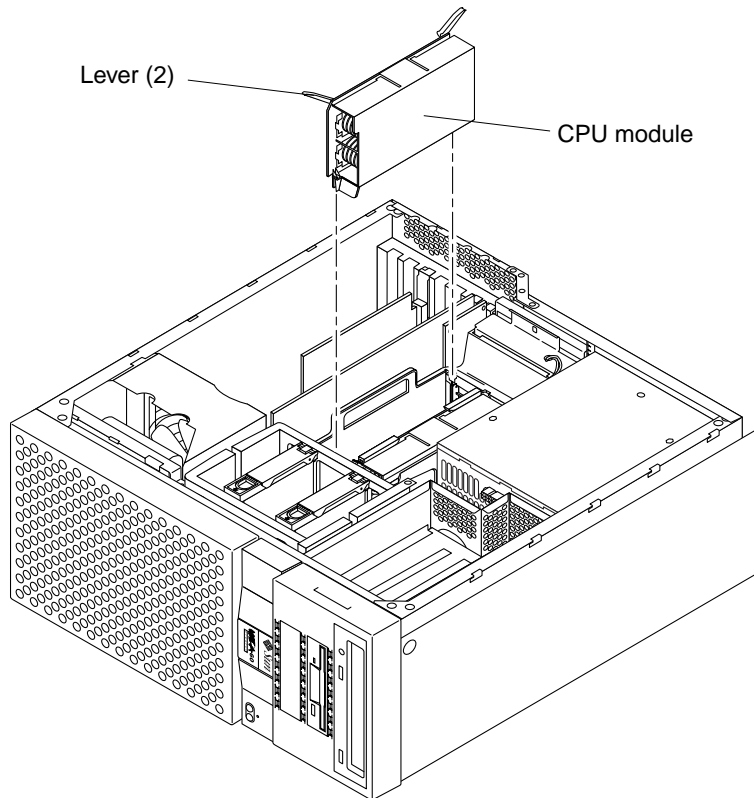

FIGURE 10-1 Removing and Replacing the CPU Module

10.1.3 Replacing the CPU Module



Caution – Use proper ESD grounding techniques when handling components. Wear an antistatic wrist strap and use an ESD-protected mat. Store ESD-sensitive components in antistatic bags before placing them on any surface.

1. **Replace the CPU module as follows (FIGURE 10-1):**
 - a. **On the antistatic mat, hold the CPU module in an upright position with the plastic surface facing you.**
 - b. **Move the levers on the CPU module to the 135-degree position.**

- c. Lower the CPU module along the vertical plastic guides until the module touches the motherboard slot socket. Lock the CPU module in place as follows:
 - i. With both hands, simultaneously turn and press the levers down to the fully horizontal position.
 - ii. Firmly press the module down into the socket until it is fully seated and the levers are fully locked.
2. Connect the AC power cord.
3. Detach the wrist strap.
4. Replace the side access cover.
See Section 7.3, “Replacing the Side Access Cover” on page 7-4.
5. Power on the system unit.
See Section 6.1, “Powering On the System Unit” on page 6-2.

10.2 NVRAM/TOD

To remove and replace the NVRAM/TOD, proceed as follows.

10.2.1 Removing the NVRAM/TOD

1. Power off the system unit.
See Section 6.2, “Powering Off the System Unit” on page 6-3.
2. Remove the side access cover.
See Section 7.1, “Removing the Side Access Cover” on page 7-2.



Caution – Use proper ESD grounding techniques when handling components. Wear an antistatic wrist strap and use an ESD-protected mat. Store ESD-sensitive components in antistatic bags before placing them on any surface.

3. Attach a wrist strap.
See Section 7.2, “Attaching the Wrist Strap” on page 7-3.
4. Remove the power supply.
See Section 8.1.1, “Removing the Power Supply” on page 8-2.

5. Remove the NVRAM/TOD as follows (FIGURE 10-2):
 - a. Locate the NVRAM/TOD and carrier on the motherboard.
 - b. Grasp the NVRAM/TOD carrier at each end and pull straight up.

Note – Gently wiggle the NVRAM/TOD as necessary.

6. Place the NVRAM/TOD and carrier on an antistatic mat.

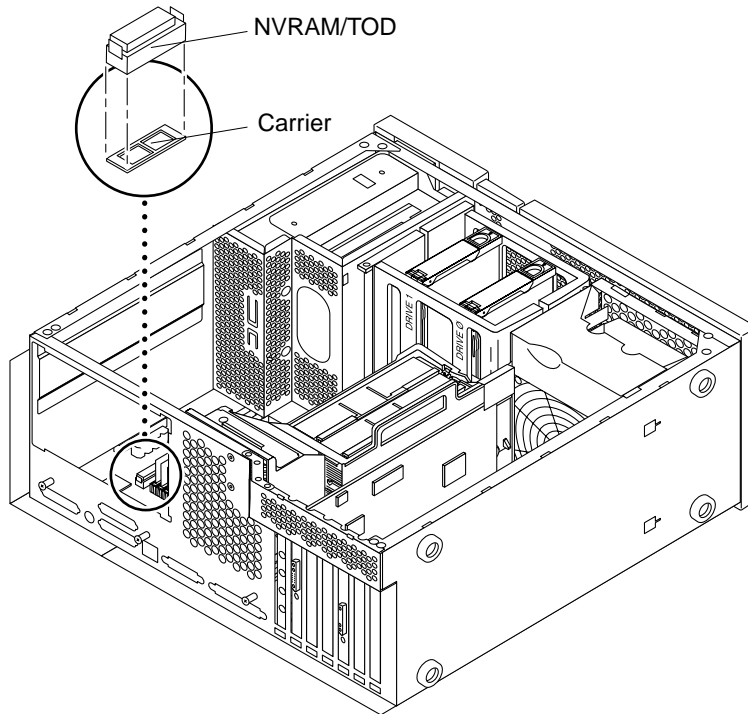

FIGURE 10-2 Removing and Replacing the NVRAM/TOD

10.2.2 Replacing the NVRAM/TOD



Caution – Use proper ESD grounding techniques when handling components. Wear an antistatic wrist strap and use an ESD-protected mat. Store ESD-sensitive components in antistatic bags before placing them on any surface.

1. **Replace the NVRAM/TOD as follows (FIGURE 10-2):**
 - a. **Position the NVRAM/TOD and carrier on the motherboard.**
 - b. **Carefully insert the NVRAM/TOD and carrier into the socket.**

Note – The carrier is keyed so the NVRAM/TOD can be installed only one way.

- c. **Push the NVRAM/TOD into the carrier until properly seated.**
2. **Replace the power supply.**

See Section 8.1.2, “Replacing the Power Supply” on page 8-3.
 3. **Connect the AC power cord.**
 4. **Detach the wrist strap.**
 5. **Replace the side access cover.**

See Section 7.3, “Replacing the Side Access Cover” on page 7-4.
 6. **Power on the system unit.**

See Section 6.1, “Powering On the System Unit” on page 6-2.

10.3 PCI Card

To remove and replace a PCI card, proceed as follows.

10.3.1 Removing a PCI Card

1. **Power off the system unit.**

See Section 6.2, “Powering Off the System Unit” on page 6-3.
2. **Disconnect cables from PCI card being removed.**
3. **Remove the side access cover.**

See Section 7.1, “Removing the Side Access Cover” on page 7-2.



Caution – Use proper ESD grounding techniques when handling components. Wear an antistatic wrist strap and use an ESD-protected mat. Store ESD-sensitive components in antistatic bags before placing them on any surface.

4. Attach the wrist strap.

See Section 7.2, “Attaching the Wrist Strap” on page 7-3.

5. Remove the PCI card as follows (FIGURE 10-3):

- a. Using a Phillips-head screwdriver, remove the screw securing the PCI card bracket tab to the system unit chassis (not illustrated).**



Caution – Avoid damaging the connector by not applying force to one end or one side of the board.

- b. At the two upper corners of the PCI card, pull the card straight up from the slot.**

- c. Remove the PCI card.**

6. Place the PCI card on an antistatic mat.

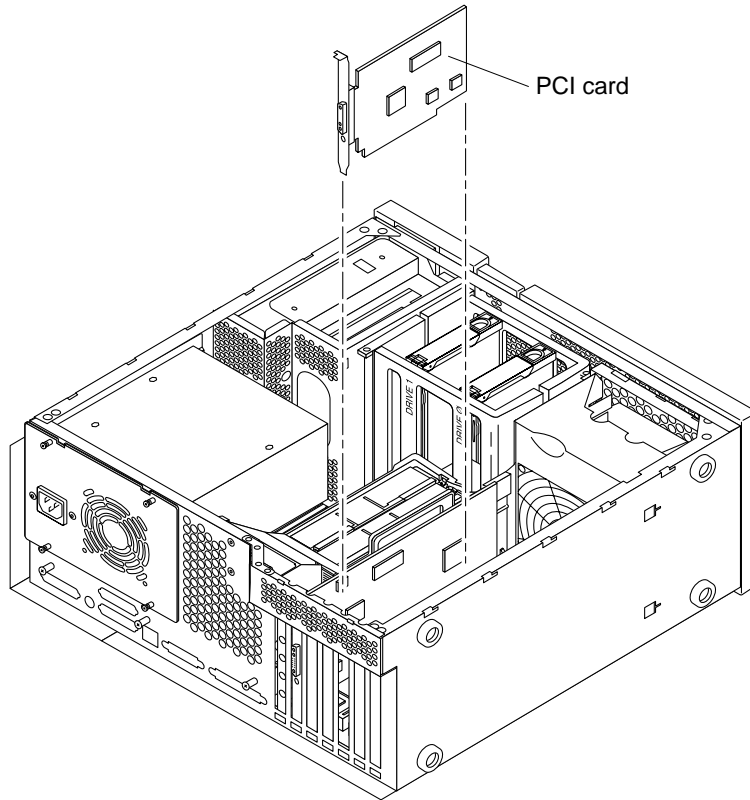

FIGURE 10-3 Removing and Replacing a PCI Card

10.3.2 Replacing a PCI Card



Caution – Use proper ESD grounding techniques when handling components. Wear an antistatic wrist strap and use an ESD-protected mat. Store ESD-sensitive components in antistatic bags before placing them on any surface.

Note – Read the PCI card product guide for information about jumper or switch settings, slot requirements, and required tools.

1. **Replace the PCI card as follows (FIGURE 10-3):**
 - a. **Position the PCI card into the chassis.**
 - b. **Lower the PCI card connector so that it touches its associated PCI card slot on the motherboard.**
 - c. **Guide the PCI card back panel into the chassis backpanel.**
 - d. **At the two upper corners of the card, push the card straight down into the slot until the card is fully seated.**
 - e. **Using a Phillips-head screwdriver, replace the screw securing the card bracket tab to the system unit chassis (not illustrated).**
2. **Replace the side access cover.**

See Section 7.3, “Replacing the Side Access Cover” on page 7-4.
3. **Connect the AC power cord.**
4. **Detach the wrist strap.**
5. **Connect all cables to the PCI slots.**
6. **Power on the system unit.**

See Section 6.1, “Powering On the System Unit” on page 6-2.

10.4 UPA Graphics Card

To remove and replace a UPA graphics card, proceed as follows.

10.4.1 Removing the UPA Graphics Card

1. Power off the system unit.

See Section 6.2, “Powering Off the System Unit” on page 6-3.

2. Disconnect the video cable from the graphics card video connector.

3. Remove the side access cover.

See Section 7.1, “Removing the Side Access Cover” on page 7-2.



Caution – Use proper ESD grounding techniques when handling components. Wear an antistatic wrist strap and use an ESD-protected mat. Store ESD-sensitive components in antistatic bags before placing them on any surface.

4. Attach the wrist strap.

See Section 7.2, “Attaching the Wrist Strap” on page 7-3.

5. Remove the UPA graphics card as follows (FIGURE 10-4):

- a. Using a Phillips-head screwdriver, remove the screw securing the graphics card bracket tab to the system unit chassis.**



Caution – Avoid applying force to one end or one side of the board or connector damage may occur.

- b. At the two upper corners of the graphics card, pull the card straight up from the slot.**

- c. Remove the UPA graphics card.**

6. Place the UPA graphics card on an antistatic mat.

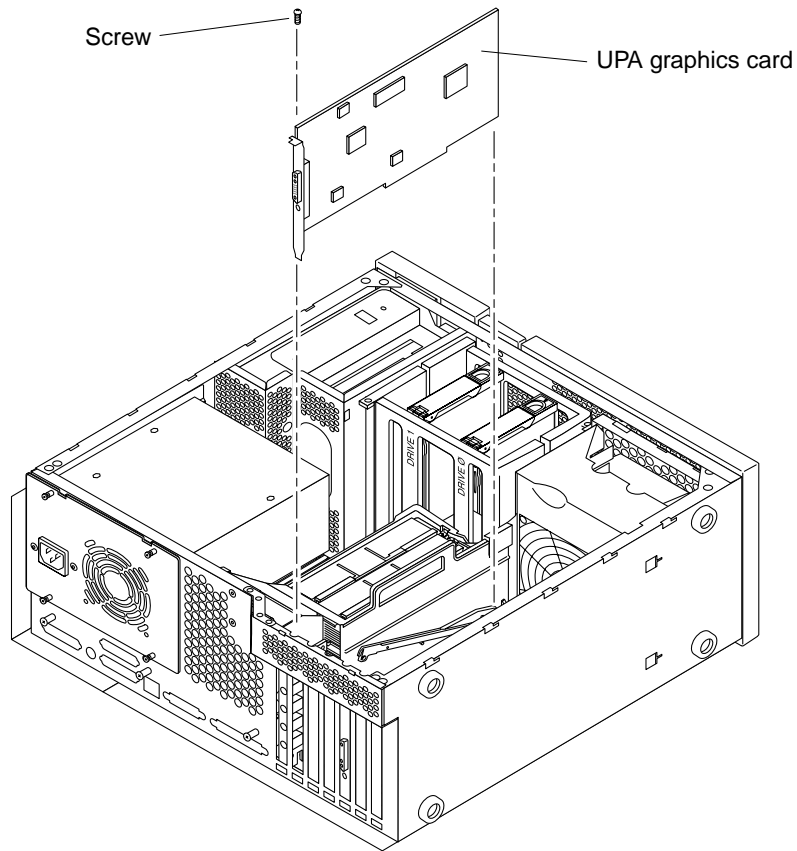

FIGURE 10-4 Removing and Replacing a UPA Graphics Card

10.4.2 Replacing the UPA Graphics Card



Caution – Use proper ESD grounding techniques when handling components. Wear an antistatic wrist strap and use an ESD-protected mat. Store ESD-sensitive components in antistatic bags before placing them on any surface.

1. **Replace the UPA graphics card as follows (FIGURE 10-4):**
 - a. **Position the UPA graphics card into the chassis.**
 - b. **Guide the UPA graphics card back panel into the chassis backpanel.**

- c. Lower the UPA graphics card connector so that it touches its associated UPA card slot on the motherboard.



Caution – Avoid damaging the connector by not applying force to one end or one side of the board.

Note – The UPA graphics card connector is a double-row connector that requires two levels of insertion. When installing the graphics card, ensure that the connector is fully seated into the slot.

- d. At the two upper corners of the card, push the card straight down into the slot until the card is fully seated.
 - e. Using a Phillips-head screwdriver, replace the screw securing the card bracket tab to the system unit chassis.
2. Connect the AC power cord.
 3. Detach the wrist strap.
 4. Replace the side access cover.
See Section 7.3, “Replacing the Side Access Cover” on page 7-4.
 5. Connect the video cable to the graphics card video connector.
 6. Power on the system unit.
See Section 6.1, “Powering On the System Unit” on page 6-2.

10.5 DIMM

To remove and replace a DIMM, proceed as follows.



Caution – DIMMs consist of electronic components that are extremely sensitive to static electricity. Ordinary amounts of static electricity from clothing or work environment can destroy the DIMM.



Caution – When removing a DIMM, an identical replacement is required. The replacement DIMM must be inserted into the same socket as the removed DIMM.



Caution – Each DIMM bank must contain at least four DIMMs of equal density (for example: four 32-Mbyte DIMMs) to function properly. Do not mix DIMM densities in any bank.

Note – The system unit *must* have at least four identical DIMMs installed in any DIMM bank. TABLE 10-1 identifies DIMM installation locations.

TABLE 10-1 DIMM Bank and Bank Quad

Bank	Bank Quad
0	U0701, U0702, U0703, and U0704
1	U0801, U0802, U0803, and U0804
2	U0901, U0902, U0903, and U0904
3	U1001, U1002, U1003, and U1004

10.5.1 Removing a DIMM



Caution – Handle DIMMs only by the edges. Do not touch the DIMM components or metal parts. Always wear a grounding strap when handling a DIMM.

1. Power off the system unit.

See Section 6.2, “Powering Off the System Unit” on page 6-3.

2. Remove the side access cover.

See Section 7.1, “Removing the Side Access Cover” on page 7-2.



Caution – Use proper ESD grounding techniques when handling components. Wear an antistatic wrist strap and use an ESD-protected mat. Store ESD-sensitive components in antistatic bags before placing them on any surface.

3. Attach the wrist strap.

See Section 7.2, “Attaching the Wrist Strap” on page 7-3.

- 4. Remove the power supply.**
See Section 8.1.1, “Removing the Power Supply” on page 8-2.
- 5. Locate the DIMM to be removed.**
- 6. Push the lever away from the DIMM.**
- 7. Remove the DIMM from the socket (FIGURE 10-5).**
- 8. Place the DIMM on an antistatic mat.**

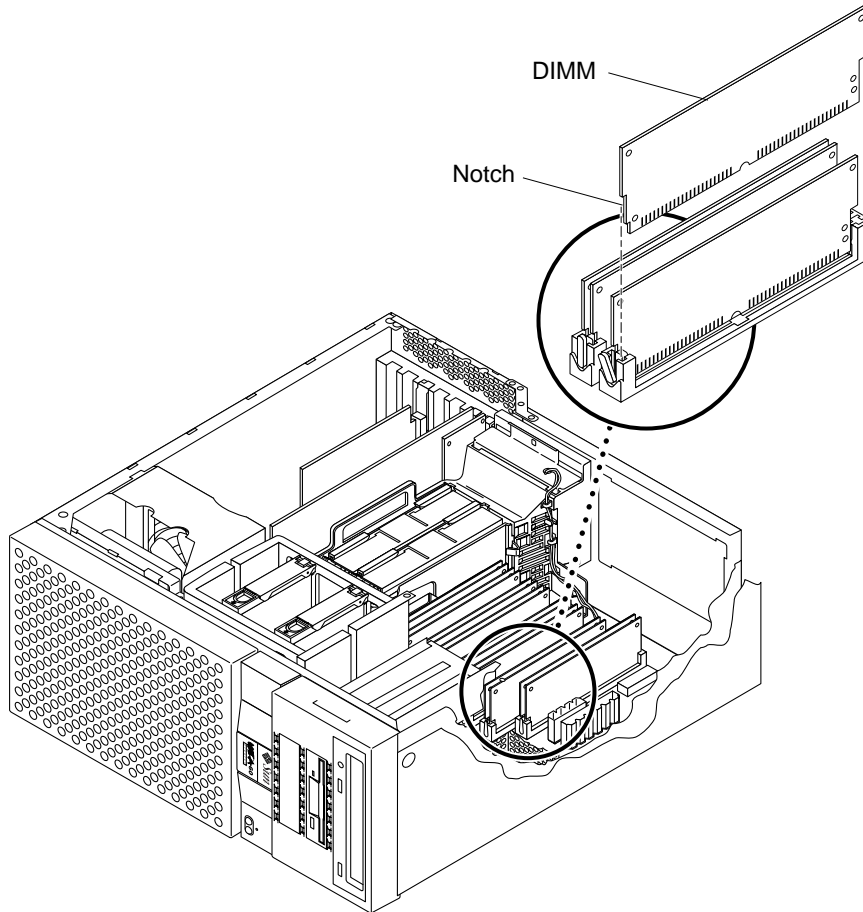

FIGURE 10-5 Removing and Replacing a DIMM

10.5.2 Replacing a DIMM



Caution – DIMMs are made of electronic components that are extremely sensitive to static electricity. Ordinary amounts of static electricity from clothing or work environment can destroy the DIMM.



Caution – Do not remove any DIMM from the antistatic container until ready to install it on the motherboard. Handle DIMMs only by their edges. Do not touch DIMM components or metal parts. Always wear a grounding strap when handling DIMMs.



Caution – Each DIMM bank must contain four DIMMs of equal density (for example four 32-Mbyte DIMMs) to function properly. Do not mix DIMM density in any bank.



Caution – Use proper ESD grounding techniques when handling components. Wear an antistatic wrist strap and use an ESD-protected mat. Store ESD-sensitive components in antistatic bags before placing them on any surface.

1. **Locate the DIMM slot(s) on the motherboard where DIMMs were removed.**

Note – The system unit *must* have four identical DIMMs installed in any DIMM bank. TABLE 10-1 identifies DIMM installation locations.



Caution – Hold DIMMs only by the edges.

2. **Remove the DIMM from the antistatic container.**
3. **Install the DIMM as follows (FIGURE 10-5):**
 - a. **Position the DIMM in the socket, ensure that the notch is on the same side as the lever.**
 - b. **Using the thumbs, press firmly on the DIMM top until the DIMM is properly seated.**

Note – Proper DIMM seating is verified by a clicking sound. Ensure proper seating occurs.

4. Replace the power supply.

See Section 8.1.2, “Replacing the Power Supply” on page 8-3.

5. Connect the AC power cord.

6. Detach the wrist strap.

7. Replace the side access cover.

See Section 7.3, “Replacing the Side Access Cover” on page 7-4.

8. Power on the system unit.

See Section 6.1, “Powering On the System Unit” on page 6-2.

10.6 Audio Card

To remove and replace the audio card, proceed as follows.

10.6.1 Removing the Audio Card

1. Power off the system unit.

See Section 6.2, “Powering Off the System Unit” on page 6-3.

2. Disconnect any audio cables from the audio card.

3. Remove the side access cover.

See Section 7.1, “Removing the Side Access Cover” on page 7-2.



Caution – Use proper ESD grounding techniques when handling components. Wear an antistatic wrist strap and use an ESD-protected mat. Store ESD-sensitive components in antistatic bags before placing them on any surface.

4. Attach the wrist strap.

See Section 7.2, “Attaching the Wrist Strap” on page 7-3.

5. Remove the audio card as follows (FIGURE 10-6):

- a. Using a Phillips-head screwdriver, remove the screw securing the audio card bracket tab to the system unit chassis.**



Caution – Avoid damaging the connector by not applying force to one end or one side of the board.

- b. Remove the UPA graphics card(s).**

See Section 10.4.1, “Removing the UPA Graphics Card” on page 10-10.

- c. At the two upper corners of the audio card, pull the card straight up from the slot.**

- d. Remove the audio card.**

6. Place the audio card on an antistatic mat.

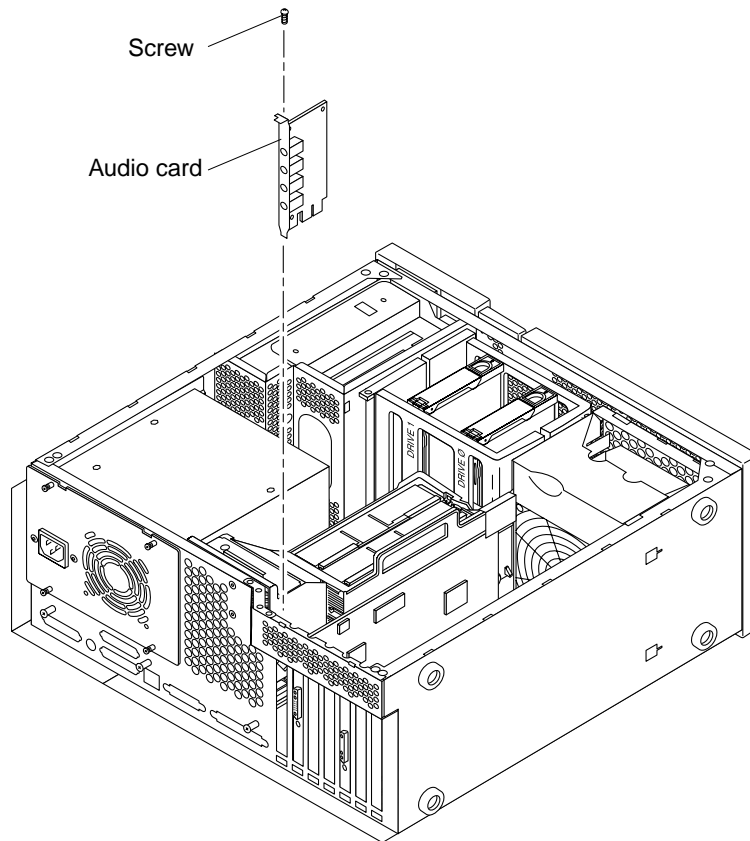

FIGURE 10-6 Removing and Replacing the Audio Card

10.6.2 Replacing the Audio Card



Caution – Use proper ESD grounding techniques when handling components. Wear an antistatic wrist strap and use an ESD-protected mat. Store ESD-sensitive components in antistatic bags before placing them on any surface.

1. **Replace the audio module as follows (FIGURE 10-6):**
 - a. **Position the audio module into the chassis.**
 - b. **Lower the audio module connector so that it touches its associated card slot on the motherboard.**

- c. **At the two upper corners of the card, push the card straight down into the slot until the card is fully seated.**
 - d. **Using a Phillips-head screwdriver, replace the screw securing the audio module to the system unit chassis.**
 - e. **Replace the UPA graphics card(s).**
See Section 10.4.2, “Replacing the UPA Graphics Card” on page 10-11.
2. **Connect the AC power cord.**
 3. **Detach the wrist strap.**
 4. **Replace the side access cover.**
See Section 7.3, “Replacing the Side Access Cover” on page 7-4.
 5. **Connect any audio cables to the audio module.**
 6. **Power on the system unit.**
See Section 6.1, “Powering On the System Unit” on page 6-2.

10.7 Motherboard

To remove and replace the motherboard, proceed as follows.



Caution – Use an antistatic mat when working with the motherboard. An antistatic mat contains the cushioning needed to protect the underside components, to prevent motherboard flexing, and to provide antistatic protection.

Note – If the motherboard is being replaced, remove all DIMMs, UPA graphics cards, PCI card(s), audio card, and CPU module prior to removing the motherboard. Note the chassis slot location for each DIMM, UPA graphics card, and PCI card prior to removal.

Note – The NVRAM/TOD contains the system host identification (ID) and Ethernet address. If the same ID and Ethernet address are to be used on the replacement motherboard, remove the NVRAM/TOD from the motherboard and install the removed NVRAM/TOD on the replacement motherboard after motherboard installation.

10.7.1 Removing a Motherboard

1. Power off the system unit.

See Section 6.2, “Powering Off the System Unit” on page 6-3.

2. Remove the side access cover.

See Section 7.1, “Removing the Side Access Cover” on page 7-2.



Caution – Use proper ESD grounding techniques when handling components. Wear an antistatic wrist strap and use an ESD-protected mat. Store ESD-sensitive components in antistatic bags before placing them on any surface.

3. Attach a wrist strap.

See Section 7.2, “Attaching the Wrist Strap” on page 7-3.

4. Remove the power supply.

See Section 8.1.1, “Removing the Power Supply” on page 8-2.

5. Remove the motherboard as follows:

a. Remove the following from the motherboard:

- PCI card(s). See Section 10.3.1, “Removing a PCI Card” on page 10-7.
- UPA graphics card(s). See Section 10.4.1, “Removing the UPA Graphics Card” on page 10-10.
- Audio card. See Section 10.6.1, “Removing the Audio Card” on page 10-16.

b. Unlatch the shroud from the PCI fan bracket hinge clip.

c. Disconnect the following:

- Peripheral cable. See Section 8.4.1, “Removing the Peripheral Power Cable Assembly” on page 8-11.

Note – Unconnected peripheral power cables should remain clipped inside the main chassis.

- External cables.
- DC power cable.
- Internal SCSI cable assembly.
- PCI fan assembly power connector.

d. Using a number 2 Phillips-head screwdriver, proceed as follows:

- Remove the three screws securing the motherboard to the chassis (FIGURE 10-7).

- Loosen the two captive screws (until they pop up) securing the shroud assembly and the motherboard to the chassis (FIGURE 10-8).

e. Grasping the shroud assembly handle, lift the motherboard from the chassis.



Caution – Handle the motherboard by the handle, back panel, or the edges only.

6. Place the motherboard on an antistatic mat.

7. Remove the following from the motherboard:

- CPU modules. See Section 10.1.2, “Removing the CPU Module” on page 10-2.
- NVRAM/TOD with carrier. See Section 10.2.1, “Removing the NVRAM/TOD” on page 10-5.
- DIMMs. See Section 10.5.1, “Removing a DIMM” on page 10-13.
- Shroud assembly. See Section 8.10.1, “Removing the Shroud Assembly” on page 8-38.

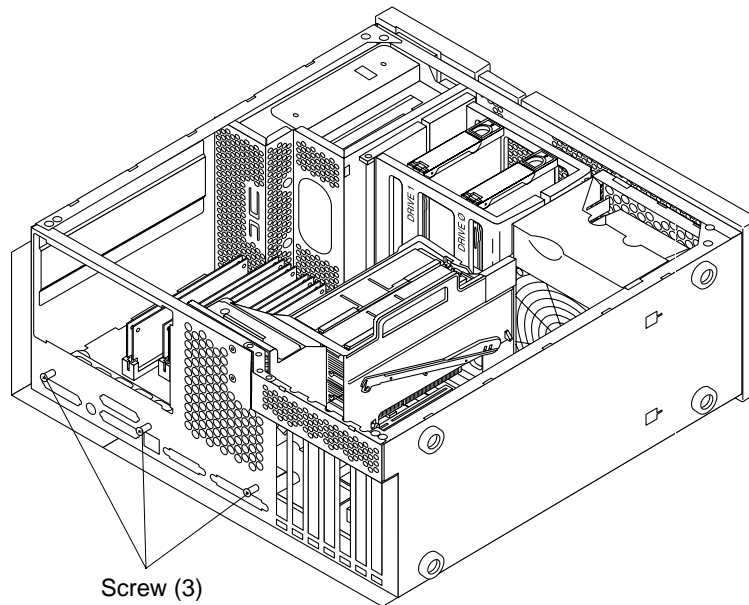

FIGURE 10-7 Removing and Replacing the Motherboard (Part 1 of 2)

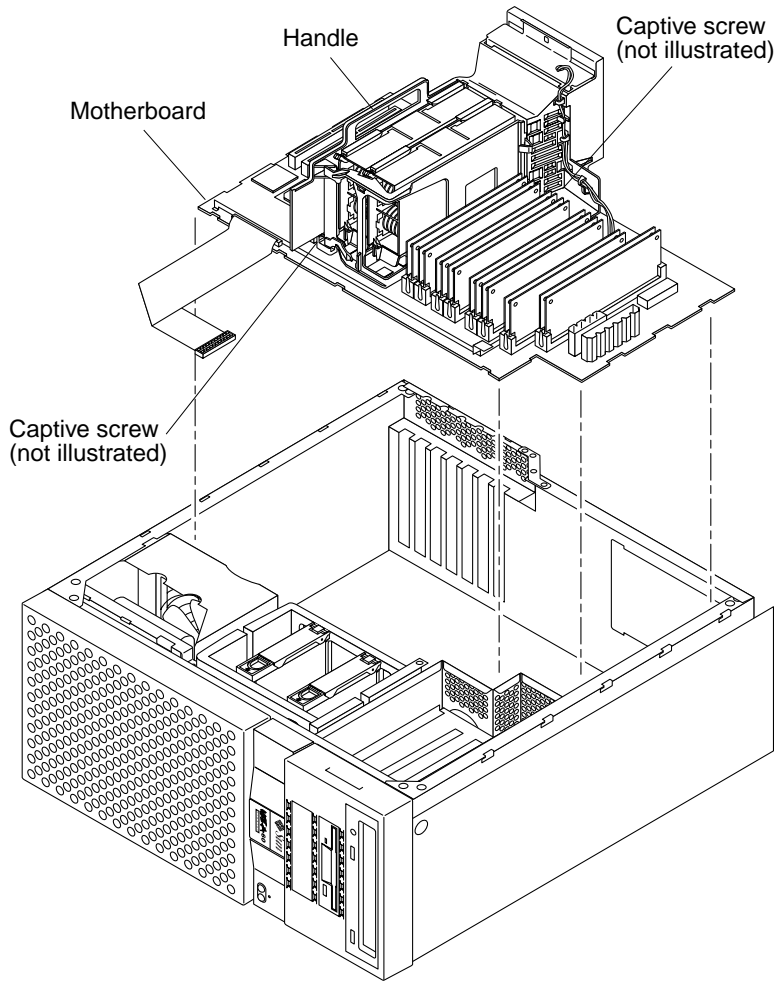

FIGURE 10-8 Removing and Replacing the Motherboard (Part 2 of 2)

10.7.2 Replacing a Motherboard



Caution – Use proper ESD grounding techniques when handling components. Wear an antistatic wrist strap and use an ESD-protected mat. Store ESD-sensitive components in antistatic bags before placing them on any surface.



Caution – Handle the motherboard by the handle, back panel, or the edges only.

Note – Jumpers J2604 and J2605 can be set to either RS-423 or RS-232 serial interface. The jumpers are preset for RS-423. RS-232 is required for digital telecommunication within the European Community.

1. Using long-nose pliers, set the motherboard serial port jumpers J2604 and J2605 (TABLE 10-2 and FIGURE 10-9).

TABLE 10-2 Serial Port Jumper Settings

Jumper	Pins 1 + 2 Select	Pins 2 + 3 Select	Default Shunt on Pins
J2604	RS-232	RS-423	2 + 3
J2605	RS-232	RS-423	2 + 3



Caution – Handle the motherboard by the handle, back panel, or the edges only.

2. Place the motherboard on an antistatic mat.

3. Replace the motherboard as follows:

a. Replace the following to the motherboard:

- NVRAM/TOD with carrier. See Section 10.2.2, “Replacing the NVRAM/TOD” on page 10-6.
- DIMMs. See Section 10.5.2, “Replacing a DIMM” on page 10-15.
- Shroud assembly. See Section 8.10.2, “Replacing the Shroud Assembly” on page 8-39.
- CPU modules. See Section 10.1.3, “Replacing the CPU Module” on page 10-4.

b. Grasping the shroud assembly handle, position the motherboard into the chassis.

c. Using a number 2 Phillips-head screwdriver, proceed as follows:

- Tighten the two captive screws securing the shroud assembly and the motherboard to the chassis (FIGURE 10-8).
- Replace the three screws securing the motherboard to the chassis (FIGURE 10-7).

d. Connect the following:

- Peripheral cable. See Section 8.4.2, “Replacing the Peripheral Power Cable Assembly” on page 8-12.

Note – Ensure that the peripheral power cable is routed through the cable routing clips.

- External cables.
- DC power cable.
- Internal SCSI cable assembly.

Note – Ensure that the SCSI cable is routed through both plastic spring clips installed adjacent to the drive bay.

- PCI fan assembly power connector.

e. Latch the shroud to the PCI fan bracket hinge clip.

f. Replace the following to the motherboard:

- PCI card(s). See Section 10.3.2, “Replacing a PCI Card” on page 10-9.
- UPA graphics card(s). See Section 10.4.2, “Replacing the UPA Graphics Card” on page 10-11.
- Audio card. See Section 10.6.2, “Replacing the Audio Card” on page 10-18.

4. Replace the power supply.

See Section 8.1.2, “Replacing the Power Supply” on page 8-3.

5. **Connect the AC power cord.**

6. **Detach the wrist strap.**

7. **Replace the side access cover.**

See Section 7.3, “Replacing the Side Access Cover” on page 7-4.

8. **Reset the #power-cycles NVRAM variable to zero as follows:**

a. **Power on the system unit.**

See Section 6.1, “Powering On the System Unit” on page 6-2.

b. **Press the keyboard Stop and A keys after the system banner appears on the monitor.**

c. **At the ok prompt, type:**

```
ok setenv #power-cycles 0
```

d. **Verify the #power-cycles NVRAM variable increments each time the system unit is power cycled.**

Note – The Solaris operating environment *Power Management* software uses the #power-cycles NVRAM variable to control the frequency of automatic system shutdown if automatic shutdown is enabled.

Illustrated Parts List

This chapter lists the authorized replaceable parts for the Ultra 60 computer (system unit). FIGURE 11-1 illustrates an exploded view of the system unit. TABLE 11-1 lists the system unit replaceable components. A brief description of each listed component is also provided.

Note – The actions required to remove and replace the major subassemblies are also illustrated with photographs and audio/visual instructions on the *Sun Ultra 60 ShowMe How Multimedia Documentation*, part number 704-5886.

Numerical references illustrated in Figure 11-1 correlate to the numerical references listed in Table 11-1. Consult your authorized Sun sales representative or service provider to order a replacement part.

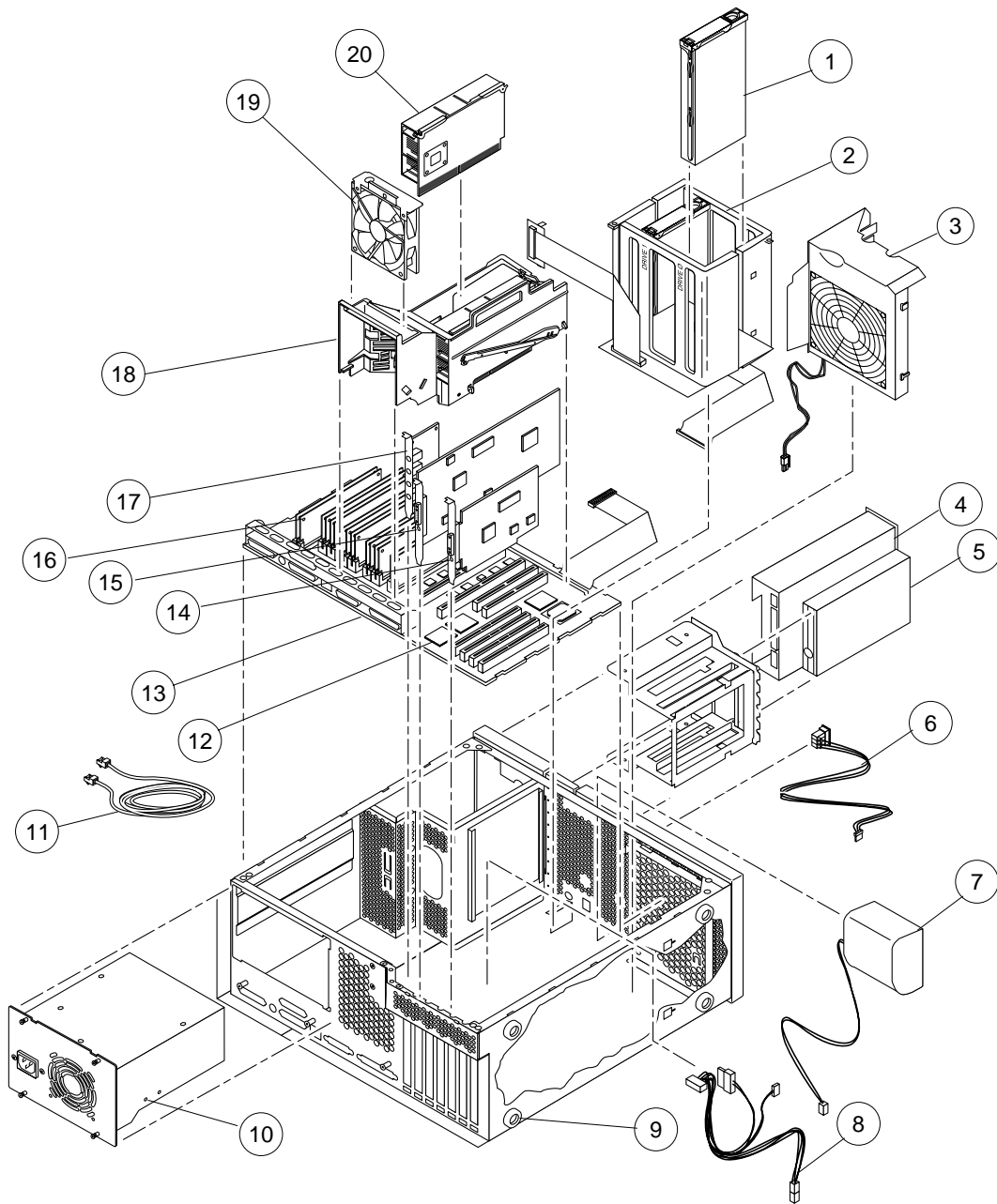

FIGURE 11-1 System Unit Exploded View

TABLE 11-1 System Unit Replaceable Components

Numerical Reference	Component	Description
1	2.1-Gbyte SCSI assembly	Hard disk drive
1	4.2-Gbyte SCSI assembly	Hard disk drive
1	9.1-Gbyte SCSI assembly	Hard disk drive
2	Hard drive bay with SCSI	Mechanical hard drive housing
3	PCI fan assembly	PCI fan
4	CD-ROM drive	12X-speed CD-ROM drive
4	4-mm tape drive	4-Gbyte/8-Gbyte, 4-mm tape drive, DDS-2
4	4-mm tape drive	12-Gbyte/24-Gbyte, 4-mm tape drive, DDS-3
4	8-mm tape drive	14-Gbyte, 8-mm tape drive
5	Manual eject floppy	Diskette drive
6	DC switch assembly	DC switch assembly
7	Speaker assembly	Speaker
8	Peripheral power cable	Peripheral power cable
9	Foot	Chassis foot
10	Power supply	Power supply, 300 watts
11	TPE cable (category 5)	Provides Ethernet interconnection
12	NVRAM/TOD	Time of day, 48T59, with carrier
13	Motherboard	System board
14	PCI card	Generic
15	Graphics card	Vertical, single buffer UPA graphics card
15	Graphics card	Vertical, double buffer plus Z (DBZ) UPA graphics card

TABLE 11-1 System Unit Replaceable Components *(Continued)*

Numerical Reference	Component	Description
16	16-Mbyte DIMM	60-ns, 16-Mbyte DSIMM
16	32-Mbyte DIMM	60-ns, 32-Mbyte DSIMM
16	64-Mbyte DIMM	60-ns, 64-Mbyte DSIMM
16	128-Mbyte DIMM	60-ns, 128-Mbyte DSIMM
17	Audio module	Audio applications
18	Shroud assembly	Fan shroud
19	CPU fan assembly	Fan assembly, part of shroud assembly
20	CPU module	300-MHz, 2-Mbyte external cache
Not illustrated	Diskette drive cable	Diskette drive cable
Not illustrated	Filler panel	Diskette drive filler panel
Not illustrated	Filler panel	CD-ROM drive or tape drive filler panel
Not illustrated	24-inch HDTV monitor	24-inch high-definition television monitor
Not illustrated	24-inch HDTV monitor	24-inch high-definition television monitor (logo-less)
Not illustrated	SCSI cable	68-pin external SCSI cable (2-m)
Not illustrated	SCSI cable	68-pin external SCSI cable (.8-m)

Product Specifications

This appendix provides product specifications for the Ultra 60 computer.

- Physical Specifications—page A-2
- Electrical Specifications—page A-2
- Environmental Requirements—page A-3

A.1 Physical Specifications

TABLE A-1 lists physical specifications for the system unit.

TABLE A-1 System Unit Physical Specifications

Specification	U.S.A.	Metric
Height	17.70 in.	45.00 cm
Width	7.50 in.	19.00 cm
Depth	17.60 in.	49.60 cm
Weight (approximate)	38.80 lb.	17.60 kg

A.2 Electrical Specifications

TABLE A-2 lists electrical specifications for the system unit.

TABLE A-2 Electrical Specifications

Parameter	Value
AC input	100 to 240 Vac, 47 to 63 Hz
DC output	350W (maximum)
Output 1	+3.3 Vdc, 50A
Output 2	+5.0 Vdc, 30A
Output 3	+12.0 Vdc, 5.0A
Output 4	-12.0 Vdc, 0.4A
Output 5	-12.0V, 0.3A

A.3 Environmental Requirements

TABLE A-3 lists environmental requirements for the system unit.

TABLE A-3 Environmental Requirements

Environmental	Operating	Non-operating
Temperature	4 to 95°F (5 to 35°C)	-4 to 140°F (-20 to 60°C)
Humidity	20 to 80% noncondensing at 95°F (35°C)	95% noncondensing at 140°F (60°C)
Altitude	10,000 ft (3 km)	40,000 ft (12 km)
Maximum dwells at extremes	16 hr	16 hr

Signal Descriptions

This appendix describes the Ultra 60 motherboard connector signals and pin assignments.

- Keyboard/Mouse and Serial Ports A and B—page B-2
- Twisted-Pair Ethernet Connector—page B-5
- UltraSCSI Connector—page B-6
- Audio Connectors—page B-10
- Parallel Port Connector—page B-11
- Media Independent Interface Connector—page B-14
- UPA Graphics Card Connector—page B-16

B.1 Keyboard/Mouse and Serial Ports A and B

B.1.1 Keyboard/Mouse Connector

The keyboard/mouse connector is a DIN-8 type connector located on the motherboard back panel. FIGURE B-1 illustrates the keyboard/mouse connector configuration and TABLE B-1 lists the connector pin assignments.

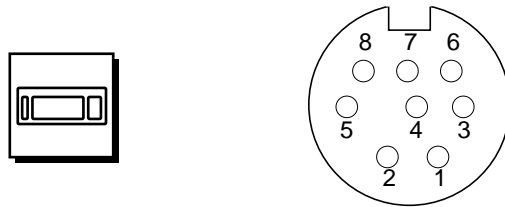

FIGURE B-1 Keyboard/Mouse Connector Pin Configuration

TABLE B-1 Keyboard/Mouse Connector Pin Assignments

Pin	Signal Name	Description
1	Gnd	Ground
2	Gnd	Ground
3	+5 Vdc	+5 Vdc
4	Mse-rxd	Mouse receive data
5	Kbd-txd	Keyboard out
6	Kbd-rxd	Keyboard in
7	Kbd-pwk	Keyboard power on
8	+5 Vdc	+5 Vdc

B.1.2 Serial Port A and B (RS-423/RS-232) Connectors

The serial port A and B connectors are DB-25 type connectors located on the motherboard back panel. FIGURE B-2 illustrates the serial port A and serial port B connector configuration and TABLE B-2 lists the connector pin assignments.

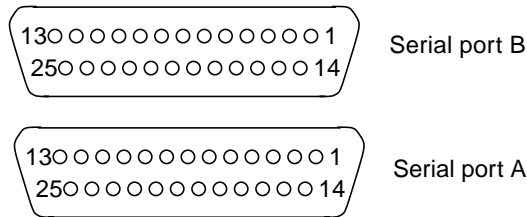

FIGURE B-2 Serial Port A and B Connector Pin Configuration

TABLE B-2 Serial Port A and B Connector Pin Assignments

Pin	Mnemonic	Signal Name	Description
1		Not connected	None
2	TXD	Transmit Data	Used by the data terminal equipment (DTE) to transmit data to the data circuit equipment (DCE). Except when control data is being sent, RTS, CTS, and DCD must be ON for this line to be active.
3	RXD	Receive Data	Used by the DCE in response to received data from the DTE.
4	RTS	Ready To Send	Used by the DTE to condition the DCE for data transmission. The transition to ON directs the DCE to go into transmit mode. The transition to OFF directs the DCE to complete the transmission.

TABLE B-2 Serial Port A and B Connector Pin Assignments (*Continued*)

Pin	Mnemonic	Signal Name	Description
5	CTS	Clear To Send	Used by the DCE to indicate if it is ready to receive data from the DTE. When CTS, DSR, RTS and DTR are ON, the DCE is ready to transmit data received from the DTE across the communications channel. When only CTS is ON, the DCE is ready to accept dialing or control signals only. When CTS is OFF, the DTE should not transfer data across TXD.
6	DSR	Data Set Ready	Used by the DCE to indicate if it is ready to operate. When DSR is ON, the DCE is connected to the line and ready to exchange further control signals to start data transfer.
7	Gnd	Signal Ground	
8	DCD	Data Carrier Detect	Used by the DCE to indicate it is receiving a suitable signal from the communications channel.
9		Not connected	None.
10		Not connected	None.
11		Not connected	None.
12		Not connected	None.
13		Not connected	None.
14		Not connected	None.
15	TRXC	Transmit Clock	Used by the DCE to provide timing information to the DTE. The DTE provides data on TXD in which the transition of the bit corresponds to the rising edge of the clock.
16		Not connected	None.
17	RTXC	Receive Clock	Used by the DCE to provide timing information to the DTE. The falling edge of the clock corresponds to the center of the data bit received on RXD.

TABLE B-2 Serial Port A and B Connector Pin Assignments (*Continued*)

Pin	Mnemonic	Signal Name	Description
18		Not connected	None.
19		Not connected	None.
20	DTR	Data Terminal Ready	Used to control switching of the DCE to the communication channel.
21		Not connected	None.
22		Not connected	None.
23		Not connected	None.
24	TXC	Terminal Clock	Generated by the DTE to provide timing information to the DCE. Used only in synchronous mode and only when the driver requests a locally generated clock. Otherwise, TXC echoes the modem-generated clock. The falling edge of the clock corresponds to the center of the data bit transmitted on TXD.
25		Not connected	None.

B.2 Twisted-Pair Ethernet Connector

The twisted pair Ethernet (TPE) connector is a RJ-45 type connector located on the motherboard back panel. FIGURE B-3 illustrates the TPE connector configuration and TABLE B-3 lists the connector pin assignments.



Caution – Connect only TPE cable into TPE connector.

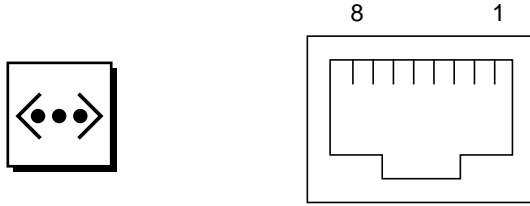

FIGURE B-3 TPE Connector Pin Configuration

TABLE B-3 TPE Connector Pin Assignments

Pin	Signal Name	Description
1	tpe0	Transmit data +
2	tpe1	Transmit data -
3	tpe2	Receive data +
4	Common mode termination	Termination
5	Common mode termination	Termination
6	tpe3	Receive data -
7	Common mode termination	Termination
8	Common mode termination	Termination

B.3 UltraSCSI Connector

The Ultra small computer system interface (UltraSCSI) connector is located on the motherboard back panel. FIGURE B-4 illustrates the UltraSCSI connector configuration and TABLE B-4 lists the connector pin assignments.

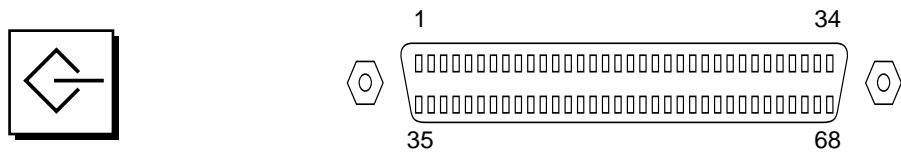

FIGURE B-4 UltraSCSI Connector Pin Configuration

TABLE B-4 UltraSCSI Connector Pin Assignments

Pin	Signal Name	Description
1	Gnd	Ground
2	Gnd	Ground
3	Gnd	Ground
4	Gnd	Ground
5	Gnd	Ground
6	Gnd	Ground
7	Gnd	Ground
8	Gnd	Ground
9	Gnd	Ground
10	Gnd	Ground
11	Gnd	Ground
12	Gnd	Ground
13	Gnd	Ground
14	Gnd	Ground
15	Gnd	Ground
16	Gnd	Ground

TABLE B-4 UltraSCSI Connector Pin Assignments (*Continued*)

Pin	Signal Name	Description
17	Termpower	Termpower
18	Termpower	Termpower
19	Not used	Undefined
20	Gnd	Ground
21	Gnd	Ground
22	Gnd	Ground
23	Gnd	Ground
24	Gnd	Ground
25	Gnd	Ground
26	Gnd	Ground
27	Gnd	Ground
28	Gnd	Ground
29	Gnd	Ground
30	Gnd	Ground
31	Gnd	Ground
32	Gnd	Ground
33	Gnd	Ground
34	Gnd	Ground
35	Dat<12>_	Data 12
36	Dat<13>_	Data 13
37	Dat<14>_	Data 14
38	Dat<15>_	Data 15
39	Par1 l_	Parity 1

TABLE B-4 UltraSCSI Connector Pin Assignments (*Continued*)

Pin	Signal Name	Description
40	Dat<0>_	Data 0
41	Dat<1>_	Data 1
42	Dat<2>_	Data 2
43	Dat<3>_	Data 3
44	Dat<4>_	Data 4
45	Dat<5>_	Data 5
46	Dat<6>_	Data 6
47	Dat<7>_	Data 7
48	Par0 l_	Parity 0
49	Gnd	Ground
50	Term_dis_	Term disable
51	Termpower	Termpower
52	Termpower	Termpower
53	Not used	Undefined
54	Gnd	Ground
55	Atn_	Attention
56	Gnd	Ground
57	Bsy_	Busy
58	Ack_	Acknowledge
59	Rst_	Reset
60	Msg_	Message
61	Sel_	Select
62	Cd_	Command

TABLE B-4 UltraSCSI Connector Pin Assignments (*Continued*)

Pin	Signal Name	Description
63	Req_	Request
64	IO_	In/Out
65	Dat<8>_	Data 8
66	Dat<9>_	Data 9
67	Dat<10>_	Data 10
68	Dat<11>_	Data 11

Note: _ (underscore) signifies active low

B.4 Audio Connectors

The audio connectors are located on the audio card. These connectors use EIA standard 3.5-mm/0.125-inch jacks. FIGURE B-5 illustrates each audio connector configuration and TABLE B-5 lists each connector line assignment.

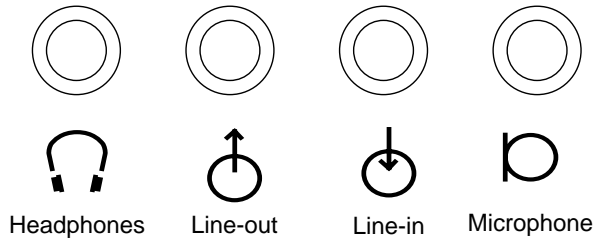

FIGURE B-5 Audio Connector Configuration

TABLE B-5 Audio Connector Line Assignment

Component	Headphones	Line Out	Line In	Microphone
Tip	Left channel	Left channel	Left channel	Left channel
Ring (center)	Right channel	Right channel	Right channel	Right channel
Shield	Ground	Ground	Ground	Ground

B.5 Parallel Port Connector

The parallel port connector is a DB-25 type connector located on the motherboard back panel. FIGURE B-6 illustrates the parallel port connector configuration and TABLE B-6 lists the connector pin assignments.

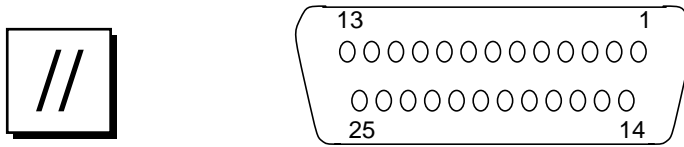

FIGURE B-6 Parallel Port Connector Pin Configuration

TABLE B-6 Parallel Port Connector Pin Assignments

Pin	Mnemonic	Signal Name	Description
1	Data_Strobe_L	Data Strobe Low	Set low during forward channel transfers to latch data into peripheral device. Set high during reverse channel transfers.
2 to 9	Data[0..7]	Data0 Thru Data7	The main data bus for the parallel port. Data0 is the least significant bit (LSB). Are not used during reverse channel transfers.
10	ACK_L	Acknowledge Low	Driven low by the peripheral device to acknowledge data byte transfer from host during forward channel transfer. Qualifies data being transferred to host in reverse channel transfer.
11	BUSY	Busy	Driven high to indicate the peripheral device is not ready to receive data during forward channel transfer. Used to send Data3 and Data7 during reverse channel transfer.
12	PERROR	Parity Error	Driven high by peripheral device to indicate an error in the paper path during forward channel transfer. Used to send Data2 and Data6 during reverse channel transfer.
13	SELECT_L	Select Low	Indicates the peripheral device is on-line during forward channel transfer. Used to send Data1 and Data5 during reverse channel transfer.

TABLE B-6 Parallel Port Connector Pin Assignments *(Continued)*

Pin	Mnemonic	Signal Name	Description
14	AFXN_L	Auto Feed Low	Set low by the host to drive the peripheral into auto-line feed mode during forward channel transfer. During reverse channel transfer, set low to indicate host can receive peripheral device data and then set high to acknowledge receipt of peripheral data.
15	ERROR_L	Error Low	Set low by the peripheral device to indicate an error during forward channel transfer. In reverse channel transfer, set low to indicate peripheral device has data ready to send to the host. Used to send Data0 and Data4.
16	INIT_L	Initialize Low	Driven low by the host to reset peripheral.
17	PAR_IN_L	Peripheral Input Low	Set low by the host to select peripheral device for forward channel transfer. Set high to indicate bus direction is from peripheral to host.
18		Signal ground	Signal ground
19		Signal ground	Signal ground
20		Signal ground	Signal ground
21		Signal ground	Signal ground
22		Signal ground	Signal ground
23		Signal ground	Signal ground
24		Signal ground	Signal ground
25		Signal ground	Signal ground

B.6 Media Independent Interface Connector

The media independent interface (MII) connector is located on the mother board back panel. FIGURE B-7 illustrates the MII connector configuration and TABLE B-7 lists the connector pin assignments.

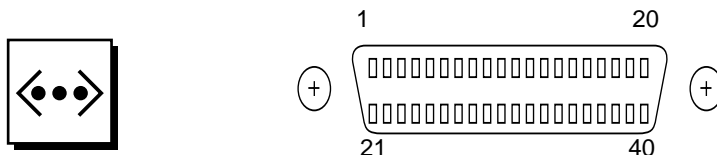

FIGURE B-7 MII Connector Pin Configuration

TABLE B-7 MII Connector Pin Assignments

Pin	Signal Name	Description
1	Pwr	Power
2	Mdio	Management data I/O
3	Mdc	Management data clock
4	Rxd3	Receive data 3
5	Rxd2	Receive data 2
6	Rxd1	Receive data 1
7	Rxd0	Receive data 0
8	Rx dv	Receive data valid
9	Rx clk	Receive clock
10	Rx er	Receive error
11	Tx er	Transmit error
12	Tx clk	Transmit clock

TABLE B-7 MII Connector Pin Assignments *(Continued)*

Pin	Signal Name	Description
13	Tx en	Transmit data enable
14	Txd0	Transmit data 0
15	Txd1	Transmit data 1
16	Txd2	Transmit data 2
17	Txd3	Transmit data 3
18	Col	Collision detected
19	Crs	Carrier sense
20	Pwr	Power
21	Pwr	Power
22	Gnd	Ground
23	Gnd	Ground
24	Gnd	Ground
25	Gnd	Ground
26	Gnd	Ground
27	Gnd	Ground
28	Gnd	Ground
29	Gnd	Ground
30	Gnd	Ground
31	Gnd	Ground
32	Gnd	Ground
33	Gnd	Ground
34	Gnd	Ground
35	Gnd	Ground

TABLE B-7 MII Connector Pin Assignments (*Continued*)

Pin	Signal Name	Description
36	Gnd	Ground
37	Gnd	Ground
38	Gnd	Ground
39	Gnd	Ground
40	Pwr	Power

B.7 UPA Graphics Card Connector

The UPA graphics card connector is located on the UPA graphics card. FIGURE B-8 illustrates the UPA graphics card connector configuration and TABLE B-8 lists the connector pin assignments.

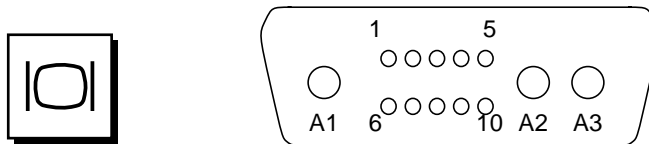

FIGURE B-8 UPA Graphics Card Connector Pin Configuration

TABLE B-8 UPA Graphics Card Connector Pin Assignments

Pin	Signal Name	Description
A1	R	Red
A2	G	Green
A3	B	Blue
1	Serial Read	Serial Read

TABLE B-8 UPA Graphics Card Connector Pin Assignments *(Continued)*

Pin	Signal Name	Description
2	Vert Sync	Vertical Sync
3	Sense <0>	Sense <0>
4	Gnd	Ground
5	Comp Sync	Composite Sync
6	Horiz Sync	Horizontal Sync
7	Serial Write	Serial Write
8	Sense <1>	Sense <1>
9	Sense <2>	Sense <2>
10	Gnd	Ground

Functional Description

This section provides a functional description for the Ultra 60 computer (system unit).

- System Unit—page C-2
- Power Supply—page C-36
- Motherboard—page C-43
- Jumper Descriptions—page C-45
- Enclosure—page C-47
- Environmental Compliance—page C-48
- Agency Compliance—page C-48
- Energy Star Software Support—page C-48

C.1 System Unit

The system unit is an UltraSPARC port architecture (UPA)-based multiprocessor machine that uses peripheral component interconnect (PCI) as the I/O bus.

The CPU modules, PSYCHO+ ASIC (UPA-to-PCI bridge), and UPA graphics cards communicate with each other using the UPA protocol. The CPU modules and the PSYCHO+ ASIC are UPA master-slave devices. The UPA graphics cards are UPA slave-only devices.

The Marvin ASIC routes UPA requests packets through the UPA address bus and controls the flow of data using the XB9+ ASIC. See FIGURE C-1.

- UPA Interconnect—page C-4
- PCI Bus—page C-6
- UltraSPARC II Processor—page C-8
- Memory System—page C-9
- Graphics and Imaging—page C-14
- Peripherals—page C-15
- Other RMA Storage Device X-Options—page C-19
- Keyboard and Mouse, Diskette, and Parallel Port—page C-19
- Serial Port—page C-22
- Ethernet—page C-24
- Audio Card and Connector—page C-28
- SCSI—page C-30
- ASICs—page C-33
- SuperIO—page C-36

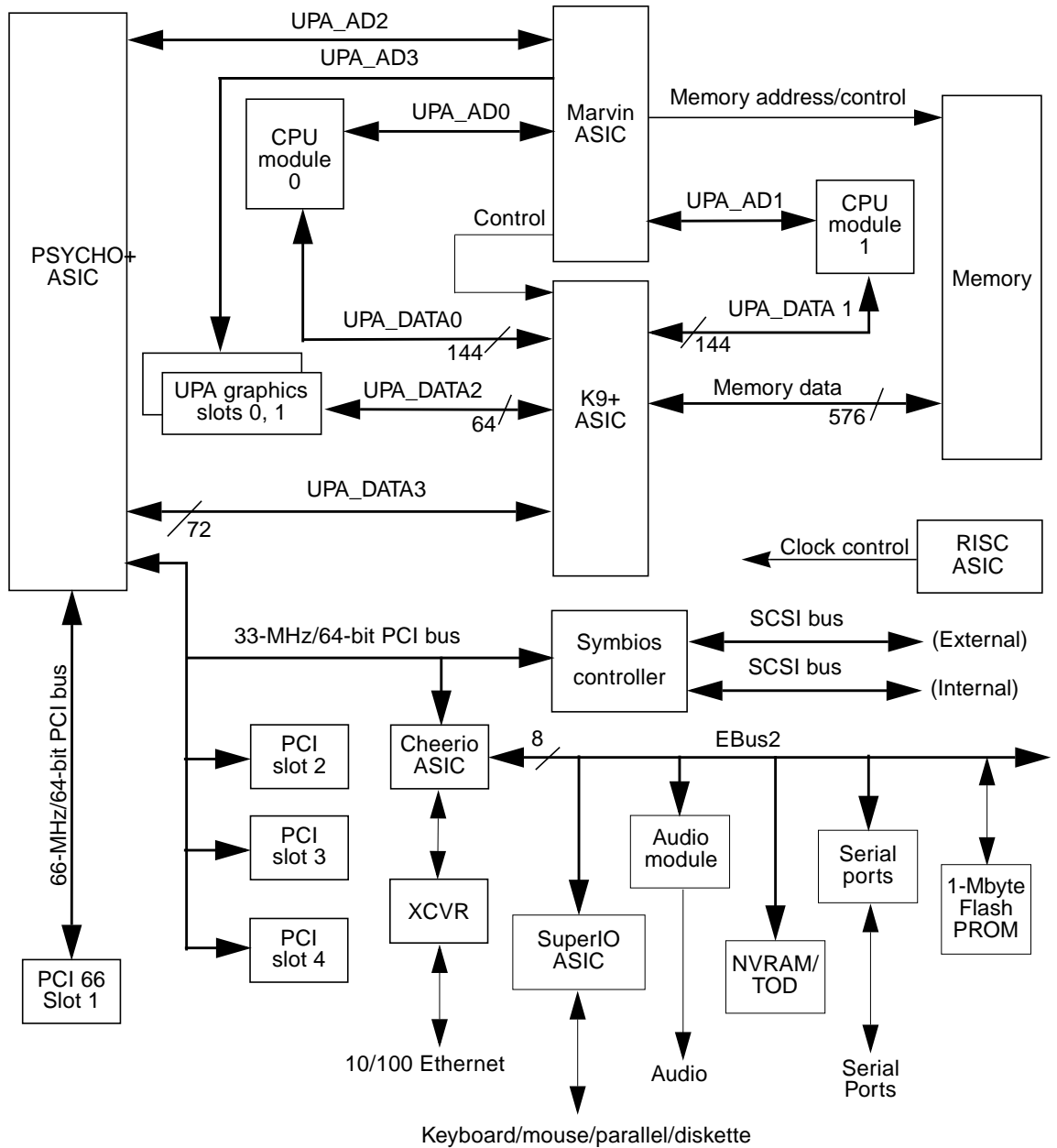

FIGURE C-1 Ultra 60 System Unit Functional Block Diagram

C.1.1 UPA Interconnect

The UltraSPARC port architecture (UPA) provides a packet-based interconnect between the UPA clients: CPU modules, PSYCHO+ ASIC, UPA graphics cards. Electrical interconnection is provided through four address buses and four data buses. See FIGURE C-2.

The four address buses are:

- UPA address bus 0 (UPA_AD0)
- UPA address bus 1 (UPA_AD1)
- UPA address bus 2 (UPA_AD2)
- UPA address bus 3 (UPA_AD3)

The four data buses are:

- UPA data bus 0 (UPA_DATA0)
- UPA data bus 1 (UPA_DATA1)
- UPA data bus 2 (UPA_DATA2)
- UPA data bus 3 (UPA_DATA3)

UPA_AD0 and UPA_AD1 connect the Marvin ASIC to the CPU modules and the PSYCHO+ ASIC. UPA_AD2 connects the Marvin ASIC to the PSYCHO+ ASIC. UPA_AD3 connects the Marvin ASIC to the UPA graphics.

Two processor data buses (UPA_DATA0 and UPA_DATA1) are bidirectional 144-bit data buses (128 bits of data and 16 bits of ECC). UPA_DATA0 and UPA_DATA1 connect each CPU module to the K9+ ASIC. The I/O data buses (UPA_DATA2 and UPA_DATA3) are bidirectional data buses. UPA_DATA2 is a 64-bit data bus that connects the PSYCHO+ ASIC and the UPA graphics. UPA_DATA3 is a 72-bit data bus (64 bits of data and eight bits of ECC) that connects the K9+ ASIC to the PSYCHO+ ASIC.

TABLE C-1 lists UPA port identification assignments. FIGURE C-2 illustrates how the UPA address and data buses are connected between the UPA and the UPA clients.

TABLE C-1 UPA Port Identification Assignments

UPA Slot Number	UPA Port ID <4:0>
CPU module slot 0	0x0
CPU module slot 1	0x1
PSYCHO+ ASIC	0x1F

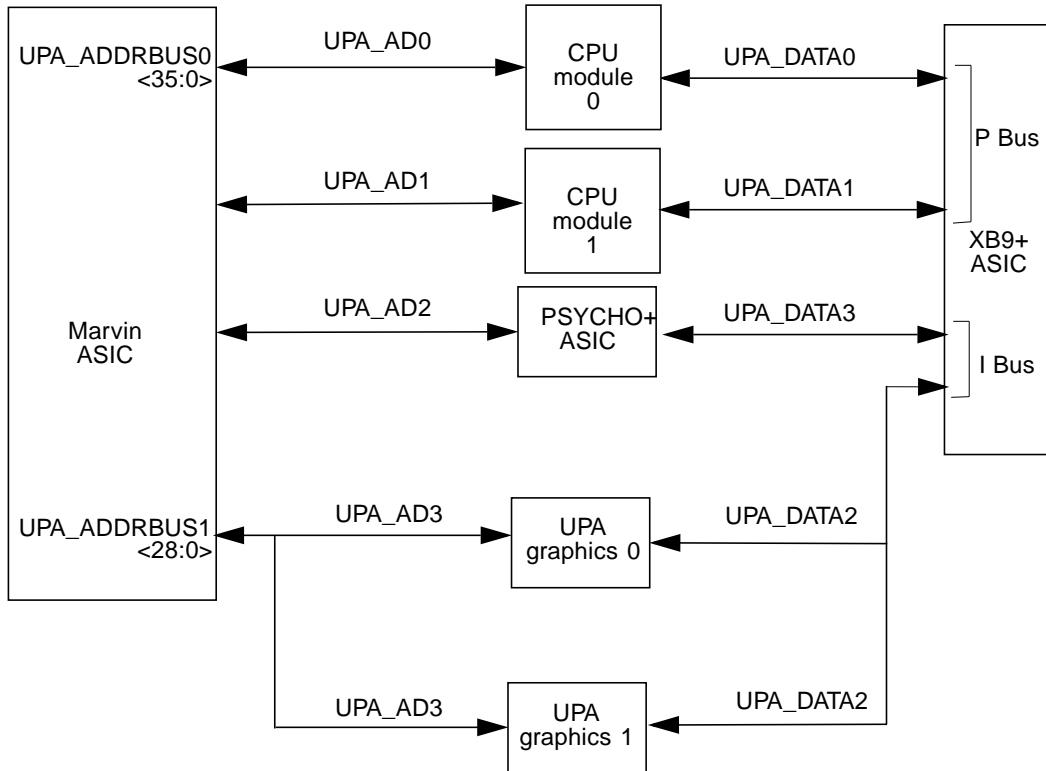

FIGURE C-2 UPA Address and Data Buses Functional Block Diagram

C.1.2 System Controller

The system controller ASIC, also known as Marvin, implements the central resource for the UPA protocol. It performs the following functions:

- Accepts UPA request packets from the three masters; two processors and PSYCHO+, and routes them to the correct slave destination.
- Maintains cache coherence between the merger buffer in PSYCHO+ and the processor cache.
- Implements blocking rules that guarantee that all requests are properly ordered.
- Controls the K9+ ASIC, and so controls the flow of data through the system.
- Contains a memory controller that supplies address and control lines to memory.
- Receives and distributes resets to all of the UPA clients in the system.
- Contains logic for waking up the processor in EnergyStar mode.

C.1.3 PCI Bus

The peripheral component interconnect (PCI) bus is a high-performance 32-bit or 64-bit bus with multiplexed address and data lines. The PCI bus provides electrical interconnect between highly integrated peripheral controller components, peripheral add-on devices, and the processor/memory system.

There are two PCI buses (FIGURE C-1). All PCI slots can accommodate “long” PCI cards, and each slot supplies up to 15W of power.

Each bus is controlled by the UPA-to-PCI bridge (PSYCHO+) ASIC. There are also two on-board controllers, the Symbios 53C876 SCSI controller and the PCI-to-Ebus/Ethernet controller (Cheerio) ASIC, on the 33-MHz PCI bus.

The first (“A”) bus is a one-slot, 3.3-Vdc, 64-bit or 32-bit, 66-MHz bus. If you plug a 33MHz PCI card in this slot, circuitry detects the card and switches the clock to 33MHz.

Note – 5V PCI cards will not work in this slot.

The second (“B”) bus is a three-slot, 5.0-Vdc, 64-bit or 32-bit, 33-MHz bus. This bus also supplies 3.3V, and 3.3V PCI cards can also be used.

C.1.3.1 PSYCHO+ ASIC

The UPT-to-PCI bridge (PSYCHO+) ASIC controls the PCI buses. It forms the bridge from the UPA bus to the PCI buses. For a brief description of the PSYCHO+ ASIC, see Section C.1.15.4, “PSYCHO+” on page C-34.

C.1.3.2 Symbios 53C876 SCSI Controller

The Symbios 53C876 SCSI controller provides electrical connection between the motherboard and the internal and external SCSI buses to the PCI bus. It supports both fast wide and UltraSCSI operation.

The Symbios controller is two SCSI controllers on the same PCI slot. Controller “A” is used to interface to internal devices. The second controller, controller “B”, is used to interface to external devices.

C.1.3.3 Cheerio ASIC

The PCI-to-EBus/Ethernet controller (Cheerio) ASIC bridges the PCI bus to the EBus, enabling communication between the PCI bus and all miscellaneous I/O functions, as well as the connection to slower on-board functions.

The Cheerio ASIC also contains the 10/100Mb Ethernet controller. For a brief description of the Cheerio ASIC, see Section C.1.15.3, “Cheerio” on page C-34.

C.1.4 EBus2 Devices

The EBus2 bus is controlled by the Cheerio ASIC, and supports several ports and devices.

C.1.4.1 Flash PROM/EPROM

Cheerio supports a 4 MB PROM address space. The Ultra 60 uses a 1 MB flash PROM.

C.1.4.2 TOD/NVRAM

The Ultra 60 uses a standard M48T59 chip containing 2k of NVRAM and a time-of-day clock and alarm.

C.1.4.3 SuperIO

The SuperIO chip implements several functions:

- Floppy drive interface.
- One IEEE 1284-compliant parallel port with ECP/EPP support.
- Two asynchronous serial ports for keyboard and mouse.

C.1.4.4 Serial Controller

The Ultra 60 uses a Siemens SAB82532 serial controller chip to implement two external serial ports. The ports operate at up to 460.8 Kbaud in asynchronous mode, and up to 384 Kbaud in synchronous mode.

C.1.4.5 Audio

Audio has been moved on to a plug-in module using a Crystal Semiconductor CS4231 codec chip.

C.1.5 UltraSPARC II Processor

The UltraSPARC II processor is a high-performance, highly-integrated superscalar processor implementing the SPARC-V9 64-bit RISC architecture. The UltraSPARC II processor is capable of sustaining the execution of up to four instructions per cycle even in the presence of conditional branches and cache misses. This sustained performance is supported by a decoupled prefetch and dispatch unit with instruction buffer. The UltraSPARC II processor supports both 2D and 3D graphics, as well as image processing, video compression and decompression, and video effects through the sophisticated visual instruction set (VIS). VIS provides high levels of multimedia performance, including real-time video compression/decompression and two streams of MPEG-2 decompression at full broadcast quality with no additional hardware support. The UltraSPARC II processor provides a 2-Mbyte ecache, with an 300-MHz operating frequency.

UltraSPARC II processor characteristics and associated features include:

- SPARC-V9 architecture compliant
- Binary compatible with all SPARC application code
- Multimedia capable visual instruction set (VIS)
 - Multiprocessing support
 - Glueless four-processor connection with minimum latency
- Snooping cache coherency
- Four-way superscalar design with nine execution units; four integer execution units
- Three floating-point execution units
- Two graphics execution units
- Selectable little- or big-endian byte ordering
- 64-bit address pointers
- 16-Kbyte non-blocking data cache
- 16-Kbyte instruction cache; single cycle branch following
- Power management
- Software prefetch instruction support
- Multiple outstanding requests

C.1.6 Memory System

The memory system (FIGURE C-3) consists of three components: the system controller (Marvin ASIC), the buffered crossbar chip (K9+ ASIC), and the memory module. The Marvin ASIC generates memory addresses and control signals to the memory module. The Marvin ASIC also coordinates the data transfers among the DIMMs through two 144-bit-wide processor data buses (UPA_DATA0 and UPA_DATA1) and the two I/O data bus; UPA_DATA2 and UPA_DATA3.

DIMMs are organized in banks in groups of four (quads). DIMM capacities of 16-Mbyte, 32-Mbyte, 64-Mbyte, and 128-Mbyte are supported by the memory module. When all DIMM banks are populated with 128-Mbyte DIMMs, maximum memory capacity is 2 gigabytes.

Organizing the four DIMM banks with 128-Mbyte (plus ECC bit) DIMMs allows data streams to be transferred on a 512-bit-wide (plus ECC) memory data bus. UPA_DATA0, UPA_DATA1, UPA_DATA2, and UPA_DATA3 bus switching The XB9+ ASIC is controlled by the Marvin ASIC and performs all data bus switching.

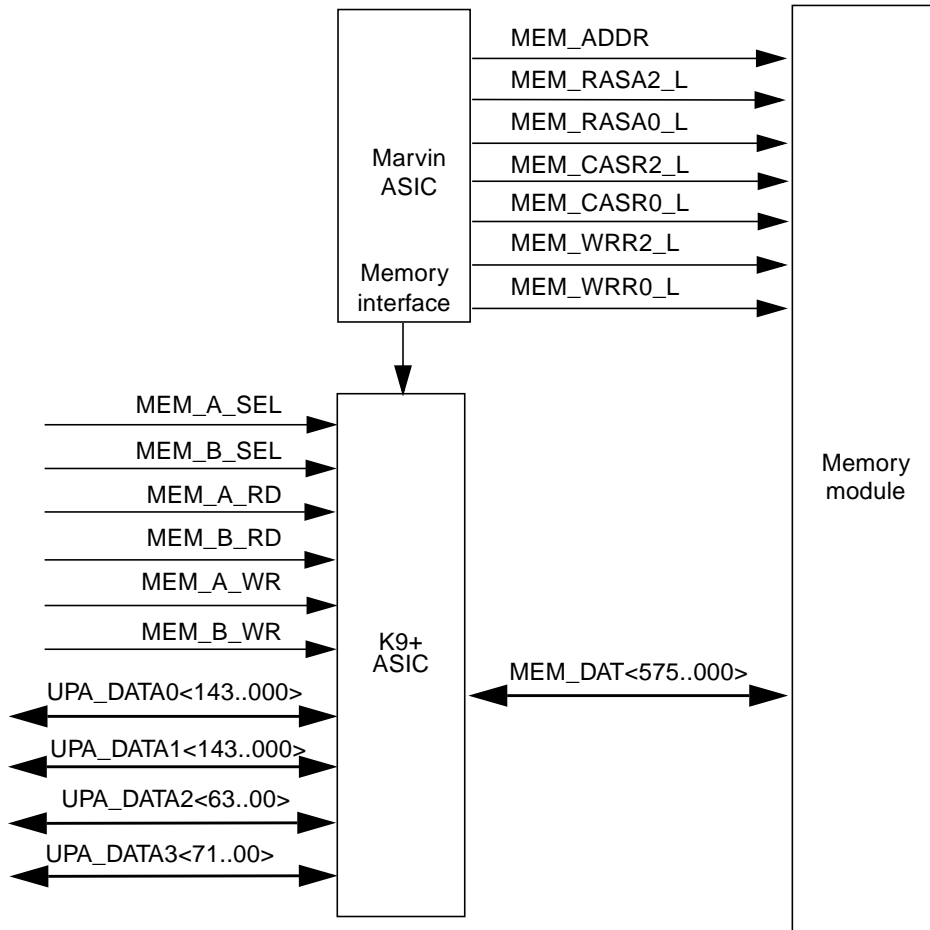

FIGURE C-3 Memory System Functional Block Diagram

As shown in FIGURE C-4, the memory module is arranged in four banks. DIMMs are always accessed four at a time. Consequently, the DIMMs must be installed in groups of four (quad) and individual DIMMs within a bank must be of equal capacity. FIGURE C-5 illustrates DIMM row mapping.



Caution – Failure to populate a DIMM bank with DIMMs of equal capacity will result in inefficient use of memory resource or system failure.

Note – For best system performance, install four identical DIMMs.

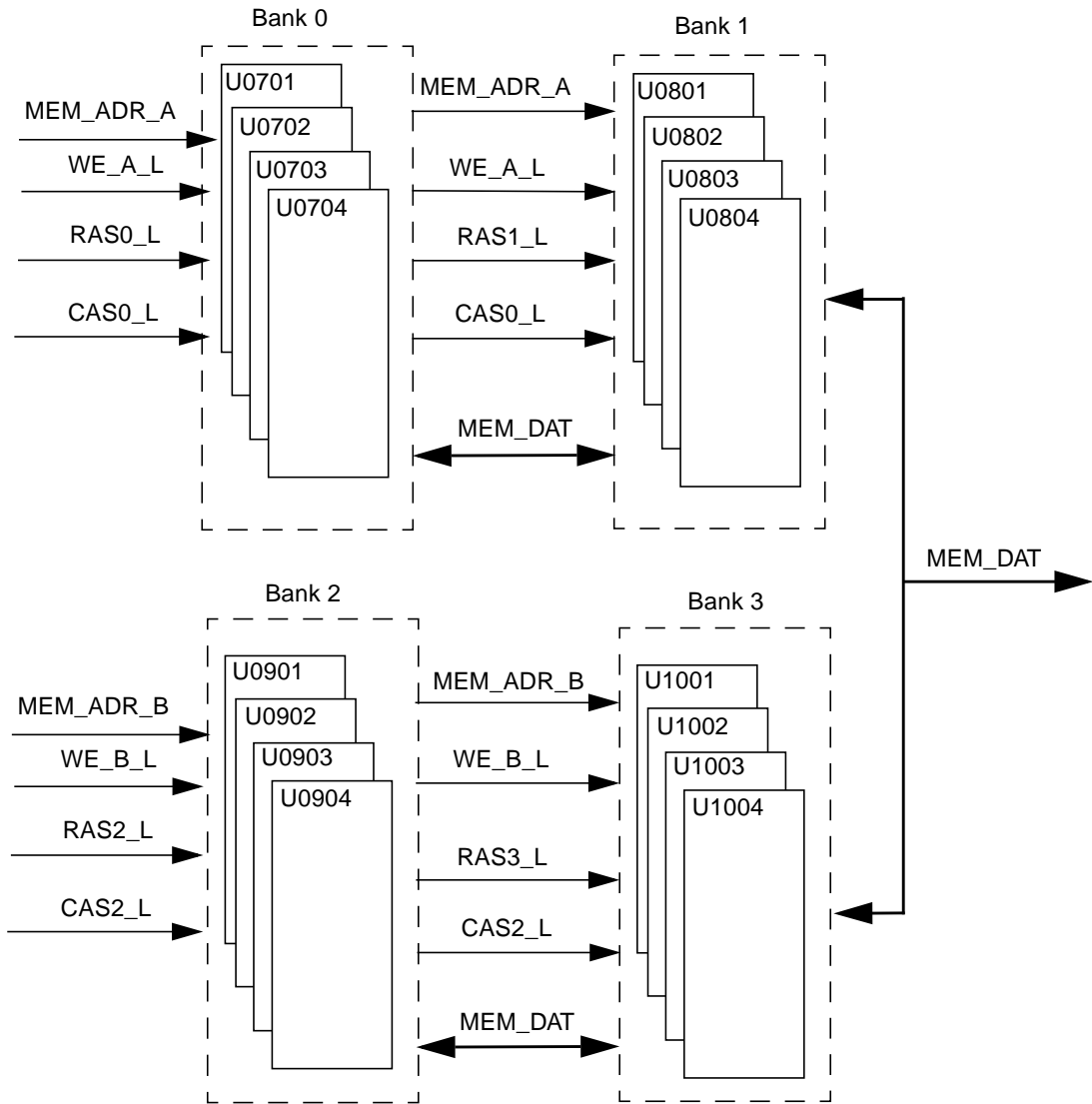

FIGURE C-4 Memory Module Functional Block Diagram

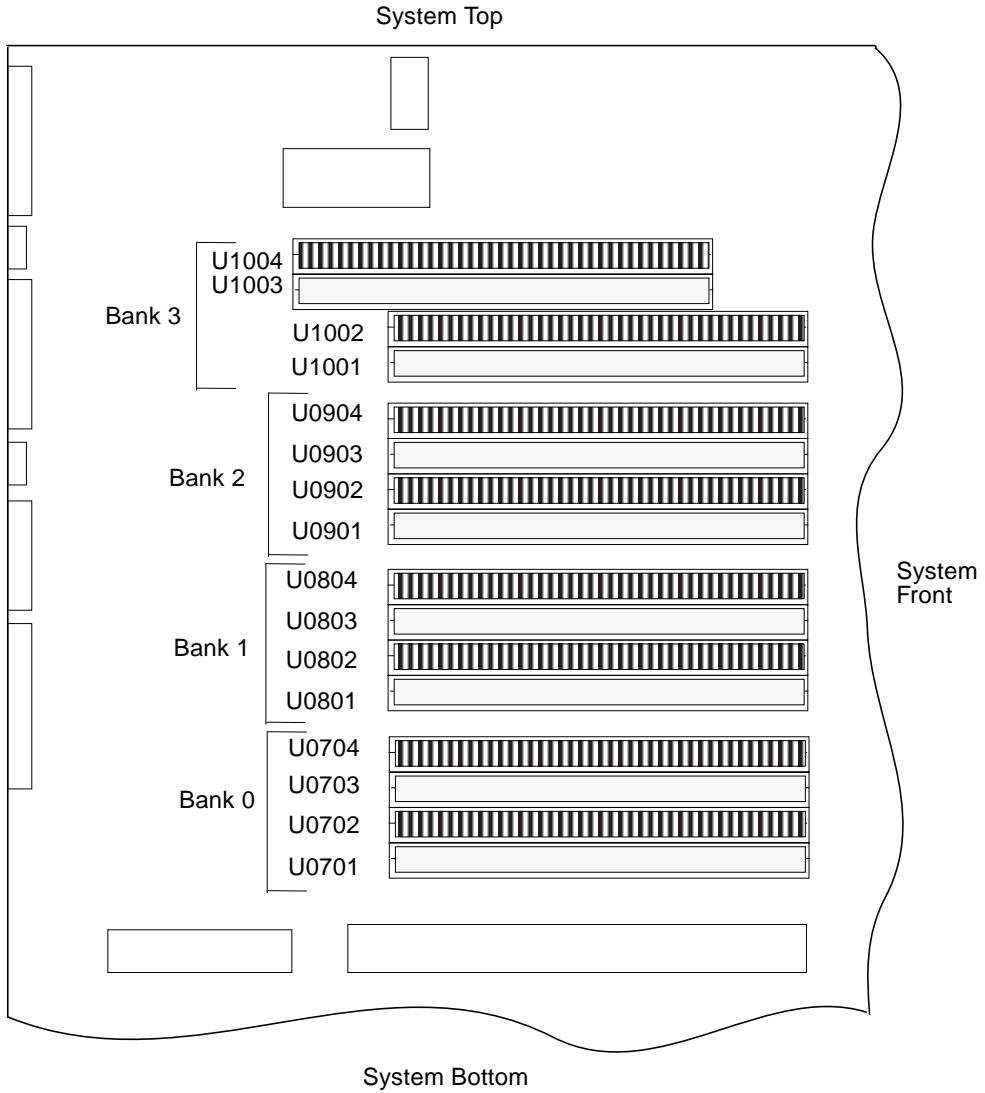

FIGURE C-5 DIMM Mapping

C.1.6.1 DIMM

The DIMM is a 60-nanosecond, fast-page-mode-style DIMM. Four DIMM configurations are supported in the system unit: 16-Mbyte, 32-Mbyte, 64-Mbyte, and 128-Mbyte. The minimum memory capacity is 64 Mbytes (four 16-Mbyte DIMMs). The maximum memory capacity is 2 Gbytes (sixteen 128-Mbyte DIMMs).

A block of data (64 bytes) always comes from one bank of DIMMs. An error code containing the address of where a failure occurred, as well as the associated syndrome, is logged when an ECC error occurs.

There are a total of four DIMM banks in the system unit. TABLE C-2 matches DIMM banks to U numbers and TABLE C-3 list physical address maps to DIMM banks. The DIMM bank numbering scheme is illustrated in FIGURE C-5.

TABLE C-2 DIMM Bank-to-U-Number Mapping

DIMM Bank	U Number
0	U0701 thru U0704
1	U0801 thru U0804
2	U0901 thru U0904
3	U1001 thru U1004

TABLE C-3 IL = 0, DIMM Bank-to-Physical Address Mapping

DIMM Bank	PA[30:28]
0	0000
	0001
1	0010
	0011
2	1000
	1001
3	1010
	1011

C.1.6.2 Memory System Timing

The Marvin ASIC generates the memory addresses and control signals to the memory system. The UPA clock is the clock source for the Marvin ASIC and operates as fast as 120-MHz.

C.1.7 Graphics and Imaging

The system unit takes advantage of UPA features to provide high-performance graphics. High-performance graphics can include a vertical, single buffer UPA graphics card or a vertical, double buffer plus Z (DBZ) UPA graphics card.

The UPA graphics card consists of the frame buffer controller (FBC) ASIC, the three-dimensional RAM (3DRAM), the RAM digital-to-analog converter (RAMDAC), and associated circuitry. The graphics card connects to the system unit through the UPA64S expansion connector.

The 3DRAM is a standard dynamic random access memory (DRAM) that includes a multi-level cache and a separate graphics port. The FBC ASIC provides acceleration for 2D and 3D imaging primitives. This, combined with the 3DRAM cache and support for graphics operations, supports a high-performance frame buffer.

The single buffer UPA graphics card accelerates applications-like windowing, 2-D graphics, imaging, and video. The DBZ UPA graphics card adds double-buffering capabilities and a Z-buffer for accelerating 3-D graphics and animation. The single buffer graphics card uses a 75-MHz frame buffer clock and the DBZ graphics card uses an 83-MHz clock.

C.1.7.1 Graphics Card Features

Features provided by the UPA graphics card include:

- YCC-to-RGB color space conversion for faster video decompression
- Contrast stretch support for imaging
- Line doubling for interlaced video writes
- Consecutive block prefetch for smart frame buffer reads
- DDC2B monitor serial communication with EDID default resolution support in the boot PROM
- 3DRAM3 OpenGL stencil function (four planes) support
- New RAMDAC support
- Single-buffered high-resolution (2.5 Mpixels) supports the following screen resolutions (DBZ graphics card only):
 - 1920 × 1360 landscape mode (HDTV)
 - 1280 × 2048 portrait mode (medical)
- Buffer B addressing for stateless (dumb frame buffer) and video accesses (DBZ graphics card only)

C.1.7.2 Graphics Card Performance

The single-buffer and DBZ graphics cards have identical window system performance characteristics, 2D graphics, and imaging and video applications. The DBZ graphics card also provides additional performance for 3D graphics and animation applications through double-buffer and Z-buffer support.

C.1.8 Peripherals

The following peripherals are supported by the system unit: CD-ROM drive, diskette drive, and hard drive as well as a listing other RMA storage devices that can be installed as X-option listed later.

C.1.8.1 CD-ROM Drive

The CD-ROM drive is a standard SCSI interface device with multimedia features. This includes multi-session capability and fast access (12X-speed) for image and video data. The CD-ROM drive dimensions are 5.94 inch (149.5 mm) x 7.78 inch (196 mm) x 1.71 inch (43 mm) and the drive slot is a standard 1.6-inch (40.64 mm) bay that uses industry standard bezels. Headphone access, eject, pin eject, and volume control are available on the front panel. Audio from the CD is available through either the front panel headphone connection, the line-out connector at the system unit rear (accessible by cabling from front to rear), or the internal speaker.

The CD-ROM drive supports an approximate data transfer rate of 600 Kbyte/s and an access time of 350 ms (maximum). The *SunCD 12X Installation and User's Guide*, part number 805-0940, provides cleaning, jumper setting, and operation instructions for the CD-ROM drive.

C.1.8.2 Diskette Drive

The system unit uses a standard 1.44-Mbyte diskette drive that is 1 inch (25.40 mm) high. The system-to-diskette drive interface is an 82077 style interface. Refer to the *Manual Eject Diskette Drive Specifications*, part number 805-1133, for cleaning, jumper setting, and instructions for the diskette drive.

SuperIO Diskette Drive Interface

The SuperIO component contains an onboard diskette drive controller. There is a 16-byte first-in-first-out (FIFO) device that buffers and supports burst and non-burst modes. The diskette drive controller handles data rates of 500 Kbps and 250 Kbps.

Supported Features

Two additional pins on the Cheerio ASIC combine with the SuperIO diskette drive interface to support all standard Sun diskette drives. This includes Density_Select-type diskette drives, Density_Sense-type diskette drives, and diskette drives that use a Disk_Change signal.

Diskette Drive Connectors

Power is supplied to the diskette drive from a pigtailed connector at the power supply. The diskette drive operates from a 5-Vdc supply and uses a maximum power of 1.1 watts during operation. A maximum of 44 milliwatts is used during

standby mode. The diskette drive is connected to the SCSI backplane with a 34-pin ribbon cable. The maximum cable length is 1.5 meters. From the SCSI backplane, the diskette drive is cabled to the motherboard with the SCSI connections.

Diskette Drive Signals

TABLE C-4 lists diskette drive signals by mnemonic name and provides the function.

TABLE C-4 Diskette Drive Signals and Functions

Signal Name	Function
MODE_SELECT	When active low, MODE_SELECT sets the drive for a 1.2-Mbyte formatted disk. When active high, MODE_SELECT sets the drive for a 1.44-Mbyte formatted disk.
HIGH_DENSITY_IN_L	When active low, HIGH_DENSITY_IN_L indicates that a high-density disk is inserted into the drive.
NDEX	When active, INDEX indicates the beginning of each track. An active pulse is sent for each disk rotation.
DRIVE_SELECT	When set true, DRIVE_SELECT enables the drive to respond to other input signals.
MOTOR_ENABLE	When set low, MOTOR_ENABLE initiates the spindle motor rotation.
DIRECTION	When active high, DIRECTION indicates movement of the magnetic head assembly toward the outer cylinders. When active low, indicates movement of the magnetic head assembly toward the inner cylinders.
STEP	On the trailing edge, STEP moves the magnetic head in the direction specified by DIRECTION at a rate of one cylinder per pulse.
WRITE_DATA	WRITE_DATA supplies the disk drive with the data to be written to disk provided the WRITE_GATE signal is active low.
WRITE_GATE	When active low, WRITE_GATE enables the drive write circuits. When active high, WRITE_GATE enables drive read circuits.

TABLE C-4 Diskette Drive Signals and Functions (*Continued*)

Signal Name	Function
TRACK0	When active low, TRACK0 indicates that the track zero sensor has been activated and that the heads are over the outermost cylinder.
WRITE_PROTECT	When active low, WRITE_PROTECT indicates that the inserted diskette is write-protected and that drive write operations are disabled.
READ_DATA	When active, READ_DATA enables data from the disk to be transferred to the host through this signal line.
HEAD_SELECT	When low, HEAD_SELECT selects head 1. When high, HEAD_SELECT selects head 0.
DISK_CHANGE	When low, DISK_CHANGE indicates that the drive tape medium has been changed. DISK_CHANGE is reset when a new disk is inserted and an enable signal is sent by the host.

C.1.8.3 Hard Drives

The system unit supports two SCSI hard drive capacities: 4.2-Gbyte and 9.1-Gbyte. The 4.2-Gbyte hard drive is of the 1-inch form factor. The 9.1-Gbyte hard drive is of the 1.6-inch form factor. All hard drives have a single connector configuration. A drive bracket is used to mount the drive. TABLE C-5 lists the supported hard drives. The *4.2-Gbyte Disk Drive Specifications*, part number 802-7744, provides installation instructions, power requirements, and performance data for the 4.2-Gbyte disk drive. The *9-Gbyte Disk Drive Specifications*, part number 802-7745, provides installation instructions, power requirements, and performance data for the 9.1-Gbyte disk drive.

TABLE C-5 Supported Hard Drives

Form Factor Dimension	Disk Drive Capacity	Wide	RPM	Seek Time
1.00-inch (2.54 cm)	4.2 Gbyte	Yes	7200	9.5 ms
1.63-inch (41.3 cm)	9.1 Gbyte	Yes	7200	9.5 ms

C.1.9 Other RMA Storage Device X-Options

The system unit supports other RMA storage device X-options that can be installed in the system unit in lieu of the CD-ROM drive. These storage device X-options include the 4-GByte 4-mm DDS and DDS3 tape drives, the 12-GByte 4-mm DDS3 tape drive, the 8705XDX, 7-GByte tape drive, and the SLR5 QIC tape drive. For a listing of all X-options, refer to the product guide.

C.1.10 Keyboard and Mouse, Diskette, and Parallel Port

The keyboard and mouse, diskette, and parallel port interfaces are managed by the SuperIO component. FIGURE C-6 shows keyboard, diskette, and parallel port interface functionality. For a brief description of the SuperIO, see Section C.1.16, “SuperIO” on page C-36.

C.1.10.1 Keyboard and Mouse Port

The keyboard and mouse are connected to an 8-pin DIN connector, located on the motherboard, and to two serial ports on the SuperIO component. Each serial port on the SuperIO ASIC provides 16-byte FIFO buffering. Data is asynchronously exchanged with the keyboard and mouse at 1200 baud. Keyboard current is limited to 700 milliamperes (mA) by a resettable fuse. Only the Sun Type-5 keyboard is supported.

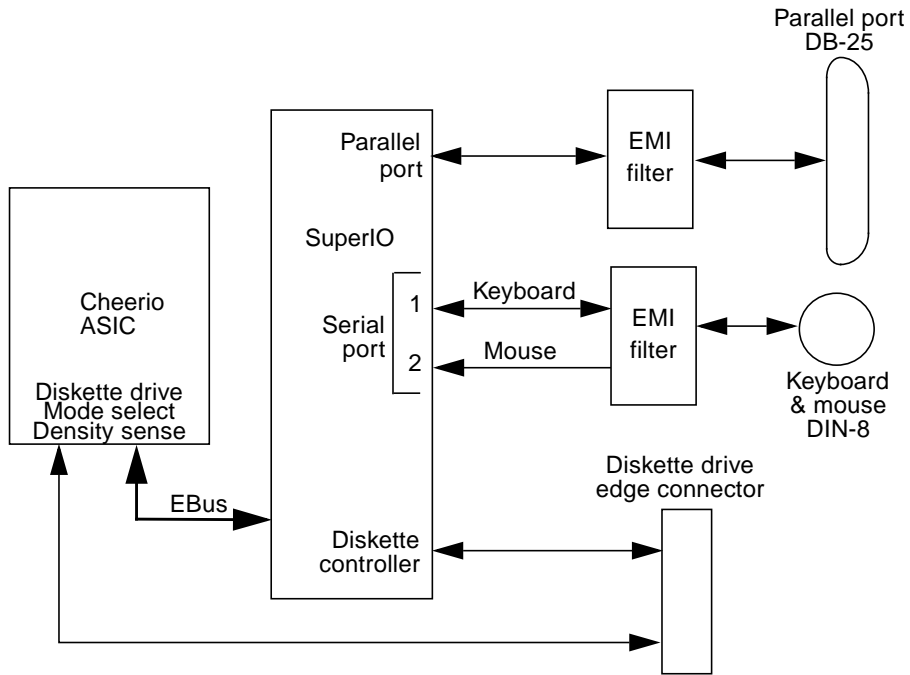

FIGURE C-6 Keyboard and Mouse, Diskette, and Parallel Port Functional Block Diagram

C.1.10.2 Diskette Port

The diskette port is supported by a diskette controller, located on the SuperIO ASIC, and the Cheerio ASIC. The diskette controller is software compatible with the DP8473, DP765A, and the N82077 diskette controller. The SuperIO ASIC is compatible with perpendicular recording drives (2.88-Mbyte formatted diskettes) as well as standard diskette drives. There is a 16-byte FIFO for buffering and support for burst and non-burst modes. The diskette controller handles data rates of 2 Mbps, 1 Mbps, 500 Kbps, and 250 Kbps.

Note – Sun utilizes the N82077 diskette controller.

There are two extra pins on the Cheerio ASIC that combine with the SuperIO component-to-diskette drive interface to support all Sun standard diskette drives. This includes diskette drives that use Density_Select and Density_Sense pins as well as diskette drives that use a Disk_Change signal. It is DMA driven via a DMA channel in the EBus interface of the Cheerio ASIC. Auto eject and manual eject diskette drives (IDs of 0 or 1, respectively) are supported.

Power is supplied to the diskette drive from a separate connector pigtailed from the power supply. The diskette drive operates from the 5-Vdc supply and draws a maximum power of 1.1 watts operating and 44 milliwatts in standby mode. The diskette drive is connected to the SCSI backplane with a 34-pin ribbon cable. Maximum cable length is 1.5 meters. From the SCSI backplane, it is cabled to the motherboard with the SCSI connections.

C.1.10.3 Parallel Port

The parallel port is supported by an IEEE 1284-compatible parallel port controller that is located on the SuperIO component. The parallel port controller is a PC-industry-standard controller that achieves a 2-megabits per second (Mbps) data transfer rate. The parallel port controller interface supports the ECP protocol as well as the following:

- Centronics – Provides a widely accepted parallel port interface.
- Compatibility – Provides an asynchronous, byte-wide forward (host to peripheral) channel with data and status lines used according to their original definitions.
- Nibble mode – Provides an asynchronous, reverse (peripheral-to-host) channel, under control of the host. Data bytes are transmitted as two sequential, four-bit nibbles using four peripheral-to-host status lines.

Parallel Port Cables

The parallel port cable is IEEE1284 compliant and consists of 18 pairs of signal wires that are double shielded with braid and foil. The maximum length of the parallel port cable is 2 meters.

Electrical Characteristics

Drivers operate at a nominal 5-Vdc transistor-transistor logic (TTL) levels. The maximum open circuit voltage is 5.5 Vdc and the minimum is -0.5 Vdc. A logic high-level signal is at least 2.4 Vdc at a source current of 0.32 mA and a logic low-level signal is no more than 0.4 Vdc at a sink current of 14 mA.

Receivers also operate at nominal 5-Vdc TTL levels and can withstand peak voltage transients between -2 Vdc and 7 Vdc without damage or improper operation. The high-level threshold is less than or equal to 2.0 Vdc and the low-level threshold is at least 0.8 Vdc. Sink current is less than or equal to 0.32 mA at 2.0 Vdc and source current is less than or equal to 12 mA at 0.8 Vdc.

C.1.11 Serial Port

The system unit incorporates two serial ports. Each serial port is synchronous and asynchronous with full modem controls. All serial port functions are controlled by a serial port controller that is electrically connected to the system through the EBus. Line drivers and line receivers control the serial port signal levels and provide RS-232 and RS-423 compatibility. Each serial port interfaces through its own DB-25 connector.

The major features of each serial port include:

- Two fully functional synchronous and asynchronous serial ports
- DB-25 connectors
- Increased baud rate speed (to 384 Kbaud, synchronous, 460.8 Kbaud, asynchronous)
- Variable edge rate for greater performance
- EBus interface

FIGURE C-7 shows a functional block diagram of the serial port.

Serial Port Components

Serial port components include a serial port controller, line drivers, and the line receivers.

The serial port controller contains 64-byte buffers on both the input and output. This enables the serial port to require less CPU bandwidth. Interrupts are generated when the buffer reaches 32 bytes or half full. The serial port controller contains its own crystal oscillator that supports rates of up to 921.6 Kbaud.

The line drivers and line receivers are compatible with both RS-232 and RS-423. Two system board jumpers are used to set the line drivers and line receivers to either RS-232 or RS-423 protocols. The line driver slew rate is also programmable. For baud rates over 100K, the slew rate is set to 10 Vdc/ μ sec. For baud rates under 100K, the slew rate is set to 5 Vdc/ μ sec.

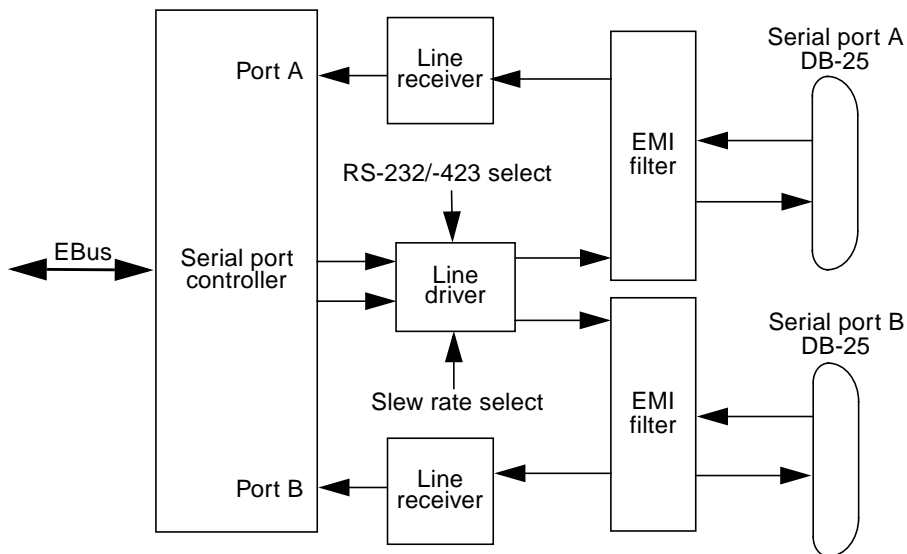

FIGURE C-7 Serial Port Functional Block Diagram

Serial Port Functions

The serial port provides a variety of functions. Modem connection to the serial port allows access to the internet. Synchronous X.25 modems are used for telecommunications in Europe. An ASCII text window is accessible through the serial port on non-graphic systems. Low speed printers, buttonboxes (for CAD/CAM applications) and exotic devices that function like a mouse are also accessible through the serial port. The additional speed of the serial port can be used to execute communications with a CSU/DSU for a partial T1 line to the internet at 384 Kbaud per second.

EIA Levels

Each serial port supports both RS-232 and RS-423 protocols. RS-232 signaling levels are between -3 Vdc and -15 Vdc and +3 Vdc and +15 Vdc. A binary 1 (001_2) is anything greater than +3 Vdc and a binary 0 (000_2) is anything less than -3 Vdc. The signal is undefined in the transition area between -3 Vdc and +3 Vdc. The line driver switches at -10 Vdc and +10 Vdc with a maximum of -12 Vdc and +12 Vdc in RS-232 mode. RS-423 is similar except that signaling levels are between -4 Vdc to -6 Vdc and +4 Vdc and +6 Vdc. The line driver switches at -5.3 Vdc and +5.3 Vdc with a maximum of -6 V and +6 Vdc. Switching from RS-232 to RS-423 protocol is accomplished by changing jumpers J2604 and J2605. Jumper positions 1 and 2 are for RS-232 and jumper positions 2 and 3 are for RS-423.

The preferred signaling protocol is RS-423. The higher voltages of R-232 make it difficult to switch at the higher baud rates. The maximum rate for RS-232 is approximately 64 Kbaud while the maximum rate for RS-423 is 460.8 Kbaud. The system default is set to RS-232.

Synchronous Rates

The serial synchronous ports operate at any rate from 50 Kbaud to 256 Kbaud when the clock is generated from the serial port controller. When the clock is generated from an external source, the synchronous ports operate at up to 384 Kbaud. Clock generation is accurate within 1 percent for any rate that is generated between 50 Kbaud and 256 Kbaud.

Asynchronous Rates

The serial asynchronous ports support twenty baud rates that are all exact divisors of the crystal frequency (with exception for 110, which is off by less than 1 percent). Baud rates include 50, 75, 110, 200, 300, 600, 1200, 1800, 2400, 4800, 9600, 19200, 38400, 57600, 76800, 115200, 153600, 230400, 307200, and 460800.

Slew Rate and Cable Length

The maximum RS-423 cable length is 118 feet (30 meters) and the maximum RS-232 cable length is 50 feet (15.24 meters). The slew rate changes depending on the speed. For speeds less than 100 Kbaud, the slew rate is set at 5 Vdc per microsecond. For rates greater than 100 Kbaud, the slew rate is increased to 10 Vdc per microsecond. This allows maximum performance for the greater baud rates and better signal quality at the lesser baud rates.

C.1.12 Ethernet

The system unit supports 10-Mbps, 10BASE-T, twisted-pair Ethernet and 100-Mbps, 100BASE-X, media independent interface (MII) Ethernet with the use of a single magnetics module. Twisted-pair Ethernet is provided through an 8-pin RJ45 connector. MII Ethernet is provided through a 40-pin MII connector. The MII port allows connection to any cable medium, including unshielded twisted-pair (UTP), shielded twisted-pair (STP), and fiber optic accompanied by the appropriate external transceiver. The system automatically senses an external transceiver, thus disabling an on-board transceiver. The Ethernet circuitry design is based on a Quality Semiconductor PHY.

The PHY chip integrates a 100BASE-T physical coding sub-layer (PCS) and a complete 10BASE-T module in a single chip. It provides a standard MII to communicate between the physical signaling and the medium access control layers for both 100BASE-X and 10BASE-T operations. The PHY IC interfaces to the 100-Mbps physical-medium-dependent transceiver Twister IC.

The 100BASE-X portion of the PHY IC consists of the following functional blocks:

- Transmitter
- Receiver
- Clock generation module
- Clock recovery module

The 10BASE-T section of the PHY IC consists of the 10-Mbps transceiver module with filters.

The 100BASE-T transceiver is included in a separate Twister IC and features adaptive equalization, baseline wander correction, and transition time control on the output signals.

The 100BASE-X and 10BASE-T sections share the following functional characteristics:

- PCS control
- MII registers
- IEEE 1149.1 controller (JTAG compliance)
- IEEE 802.3u auto negotiation

The following sections provide brief descriptions of the following:

- Automatic negotiation
- External transceivers
- External cables
- Connectors
- MII power
- MII port timing

C.1.12.1 Automatic Negotiation

Automatic negotiation controls the cable when a connection is established to a network device. It detects the various modes that exist in the linked partner and advertises its own abilities to automatically configure the highest performance mode of inter-operation, namely, 10BASE-T, 100BASE-TX, or 100BASE-T4 in half- and full-duplex modes.

The Ethernet port supports automatic negotiation. At power up, an on-board transceiver advertises 100BASE-TX in half-duplex mode, which is configured by the automatic negotiation to the highest common denominator based on the linked partner.

C.1.12.2 External Transceivers

The following external transceivers are connected through the MII port:

- 6211 Micro 100BASE-FX FastEthernet transceiver
- CT4-1030 100BASE-T4 transceiver
- CFX-107X 100BASE-FX transceiver
- XF467A MII-to-AUI transceiver

C.1.12.3 External Cables

The MII port supports a 0.5-meter long, 40-conductor, 20 signal-ground, STP cable. The single-ended impedance of the cable is 68 ohms (+/-10%). The propagation delay for each twisted-pair, measured from the MII connector to the PHY, does not exceed 2.5 nanoseconds.

The RJ45 Ethernet port supports a Category 5, UTP cable for the 100BASE-T, and a Category 3, 4, or 5 UTP cable for the 10BASE-T operation.

Note – The maximum cable segment lengths for the 100BASE-TX and 10BASE-TX are 100 meters and 1000 meters, respectively.

C.1.12.4 Connectors

A 40-pin connector is used for the MII connector. A standard 8-pin RJ45 connector with a shield is used for the AUI connector.

C.1.12.5 MII Power

A regulated 5-Vdc (+/- 5%) voltage is supplied to the PHY IC over the load range of from 0 to 750 mA. A 2-amp overcurrent protection circuit is provided by a polymer-based resettable fuse to the MII supply voltage.

MII-to-AUI connection to a 10-Mbps medium attachment unit requires a supplemental power source to meet the AUI power supply requirements. The MII-AUI converter provides the necessary supplemental power.

C.1.12.6 MII Port Timing

MII port timing encompasses two configurations involving the use of either an on-board transceiver or external transceivers. For either transceiver configuration, the MII port timing is the same because MII operates with a 40-nanosecond cycle time.

FIGURE C-8 illustrates MII being used to interconnect both integrated circuits and circuit assemblies. This enables separate signal transmission paths to exist between the reconciliation sublayer, embedded in the Cheerio ASIC, and a local PHY IC, and between the reconciliation sublayer and a remote PHY IC. The unidirectional paths between the reconciliation sublayer and the local PHY IC are composed of sections A1, B1, C1 and D1. The unidirectional paths between the reconciliation sublayer and the remote PHY IC are composed of sections A2, B2, C2, and D2.

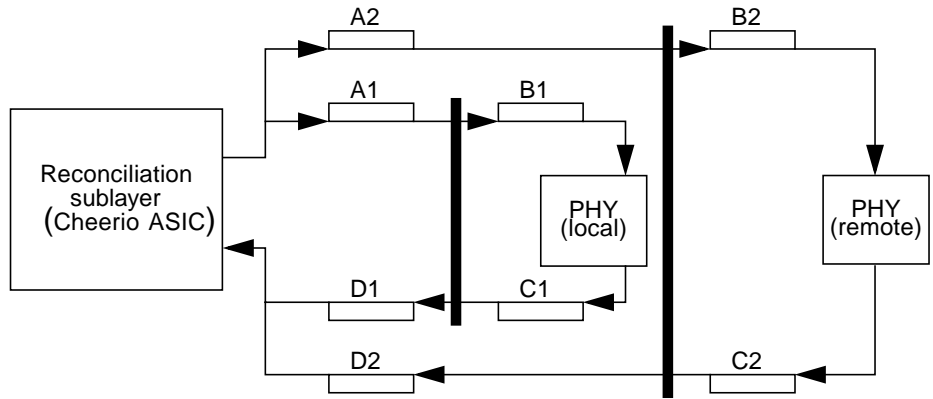

FIGURE C-8 MII Port Timing Model

C.1.13 Audio Card and Connector

The audio card provides various audio applications from telephone-quality speech to CD-quality music. The audio card supports four jacks of identical type: line in, line out, headphone out, and microphone in. TABLE C-6 lists the major features of the audio card and FIGURE C-9 illustrates a functional block diagram.

TABLE C-6 Audio Card Features

Figure Reference	Feature	Description
A	Stereo line level	Attenuated by a resistor divider network and then fed into the Line Inputs of the Codec.
B	Stereo microphone input	Buffered by a non-inverting operational amplifier (one operational amplifier for the left channel and one operational amplifier for the right channel). The left and right outputs are then fed into the left and right Mic Inputs of the Codec. A filtered +5 Vdc is fed to the signal inputs.
C	Internal CD-ROM peripheral analog outputs	Cabled to the motherboard and AC-coupled to the left and right Aux1 inputs of the Codec.
D	Codex mono-output	Fed into an active graphic equalizer to add bass boost and mid-range attenuation. Equalizer output is amplified and routed to the front mounted 16-ohm, 68-mm speaker.
E	Line output	A direct output, except E1, which enables muting of this signal. The mute function is driven from the Codec PIO lines.
F	Headphone output	Buffered by an operational amplifier to give headphone drive with low impedances of 16 ohms or more. Is independently mutable, driven from Codec PIO lines.
G	MultiMedia Codec (MMCodec)	Heart of the audio module. A single-chip, stereo, A/D and D/A converter based on delta-sigma conversion.

The audio card connector is a dual-position, standard-edge connector whose features include:

- 23 dual positions (46 total)
- 50-millimeter centerline
- 1.49 inches (total length)

The audio connector supports the following:

- Nine Codec address lines
- Eight Codec data lines
- Control lines: Write, read, Codec chip select, PROM chip select, reset
- Codec DMA support signals: playback request, playback acknowledge, capture request, and capture acknowledge
- Codec power down line
- Audio analog lines: DC volume control line
- Audio present
- Power/ground: Two +12 Vdc lines, one -12 Vdc line, one Vcc line, five digital grounds, and four analog grounds
- Two spare pins

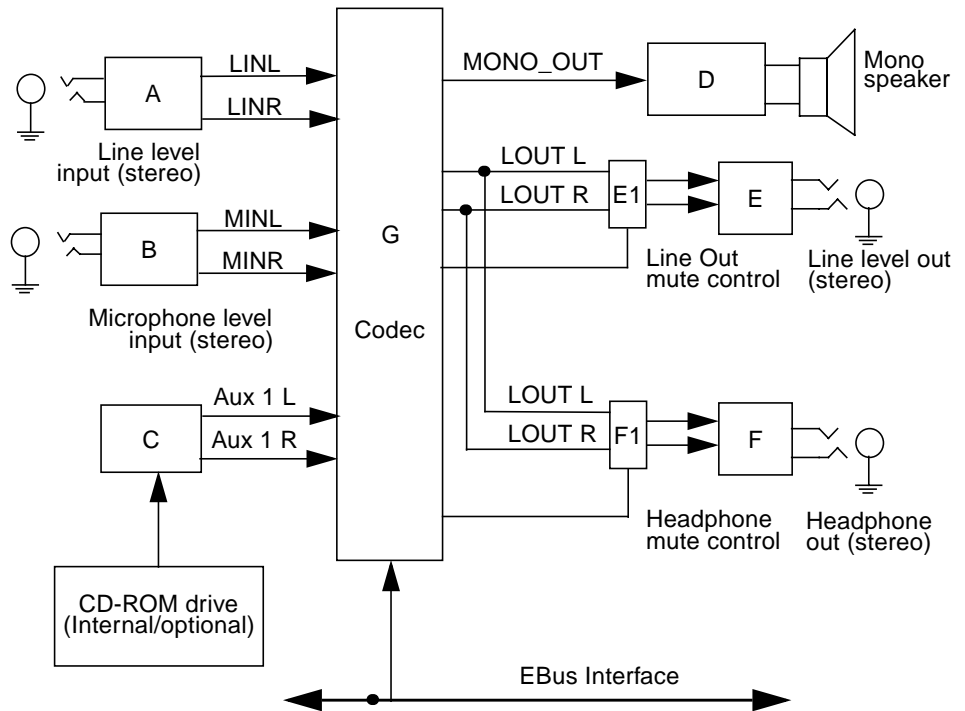

FIGURE C-9 Audio Card Functional Block Diagram

C.1.14 SCSI

The system unit implements a small computer system interface (SCSI) Fast-20 (UltraSCSI) parallel interface bus. The UltraSCSI provides the following:

- Efficient peer-to-peer I/O bus devices.
- Mechanical, electrical, and timing specification definition that support transfer rates of 20 or 40 Mbytes per second (corresponding to the data path width of an 8-bit, or 16-bit bus, respectively).
- Peak bandwidth of 40 Mbytes per second (with implemented 16-bit bus width).

The internal SCSI bus is terminated at each end. One set of terminators is located close to the CD-ROM drive connector on the CD-ROM SCSI card. A second set of terminators is located close to the 68-pin external SCSI connector. FIGURE C-10 shows the SCSI bus configuration.

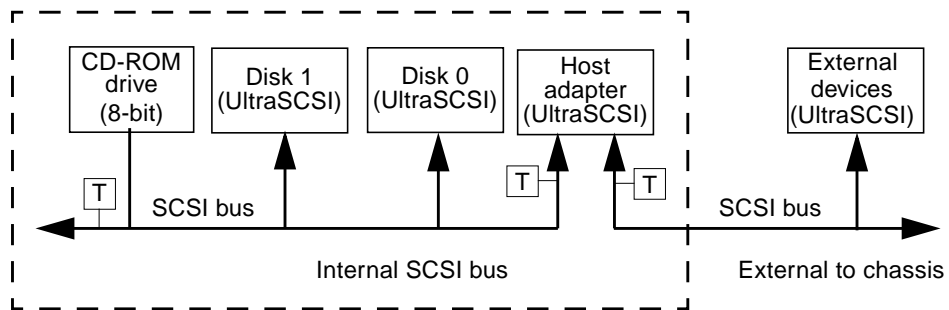

FIGURE C-10 Configuration for the SCSI Bus

C.1.14.1 Host Adapter

The host adapter is a Symbios Logic PCI-SCSI I/O processor IC. The host adapter and all target devices comply with the Fast-20 single-ended drivers and receivers characteristics. The electrical characteristics of the output buffers include:

- V_{ol} (output low) equals 0 to 0.5 Vdc with I_{ol} at 48 mA (signal asserted)
- V_{oh} (out high) equals 2.5 to 3.7 Vdc (signal negated)
- t_{rise} (rising slew rate) equals 520 mV per nanosecond maximum (0.7 to 2.3 Vdc)
- t_{fall} (falling slew rate) equals 520 mV per nanosecond maximum (2.3 to 0.7 Vdc)

The Fast-20 electrical characteristics for the host adapter and target device include:

- V_{il} (input low) equals 1.0 Vdc maximum (signal true)
- V_{ih} (input high) equals 1.9 Vdc minimum (signal false)
- I_{il} (input low current) equals +/- 20 μ A at V_i equals 0.5 Vdc
- I_{ih} (input high current) equals +/- 20 μ A at V_i equals 2.7 Vdc
- Minimum input hysteresis equals 0.3 Vdc

C.1.14.2 Supported Target Devices

The SCSI subsystem supports a maximum of four internal devices, including the host adapter. The CD-ROM drive is a narrow device. A unpack with one drive or a six-pack, accommodating six drives, can be used as external devices. TABLE C-7 lists the target devices supported by the SCSI subsystem.

TABLE C-7 Supported Target Devices

Target Device	Comment
Internal disks	Up to two 3.5-inch x 1.6-inch disks (4.2-, or 9.1-Gbyte). All internal disks are UltraSCSI-compliant.
Internal CD-ROM drive	Optional 644-Mbyte SunCD 12X speed; photo CD compatible. Headphone jack with volume control. CD-ROM drive is a narrow SCSI device.
Internal tape drive(s)	Refer to product guide.
External SPARCstorage UniPack	Refer to product guide.
External SPARCstorage SixPack	Refer to product guide.

C.1.14.3 External Cables

External UltraSCSI-compliant SCSI cables have an impedance of 90 ohm (+/- 6 ohm) and are required for UltraSCSI interface. Sun's implementation of UltraSCSI requires that the total SCSI bus length be limited to no more than approximately 20 feet (6 meters) with up to 12 Sun compensated devices. Due to the considerably short bus length, an approximate 32-inch (0.8-meter) UltraSCSI-compliant external cable is supported in addition to an approximate 6.5-foot (2-meter) UltraSCSI-compliant external cable.

Note – Consult your authorized Sun sales representative or service provider to order a 0.8-meter or a 2-meter UltraSCSI-compliant external cable.

C.1.14.4 Internal SCSI Subassembly

The internal SCSI subassembly consists of two cable assemblies and two SCSI cards. The SCSI subassembly is attached to the motherboard using an insulation displacement connector (IDC) receptacle attached to a 80-conductor cable. In addition to the SCSI signals, the 80-conductor cable carries diskette drive and system LED signals to the SCSI backplane card. The IDC receptacle mates with a right-angle plug that is mounted on the motherboard.

The 80-conductor cable attaches on the other end to the SCSI backplane card with another IDC connector. The SCSI backplane card incorporates two SCA-2 connectors for mounting the hard drives, a four-circuit power connector to supply 5 Vdc and 12 Vdc power to the hard drives, a 34-pin diskette drive signal connector, and a green, right-angle LED.

A 68-conductor cable exits the SCSI backplane card, carrying 27 SCSI signals and the *Termpower* to the internal CD-ROM drive (or tape drive). The SCSI backplane card houses the CD-ROM drive connector and three SCSI bus terminators. The *Termpower* is routed through the SCSI subassembly to connect to the terminators on the SCSI backplane card in support of the multi-host configuration. FIGURE C-11 shows the functionality of the internal SCSI subassembly.

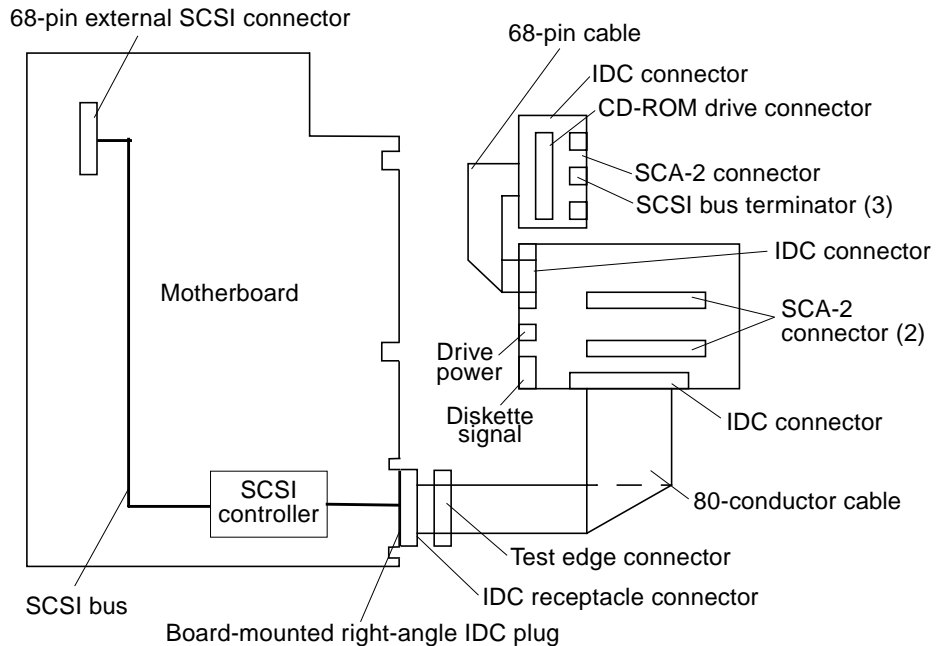

FIGURE C-11 SCSI Subassembly Functional Block Diagram

C.1.14.5 SCSI ID Selection

The motherboard host adapter is assigned the SCSI identification of 7 for both ports. The two internal drives attached to the SCA-2 connectors have a SCSI identification of 0 and 1, while the CD-ROM has an identification of 6.

C.1.15 ASICs

The system unit achieves a high level of integration through application-specific integrated circuits (ASICs). All ASICs are 1149.1 (JTAG) compliant. The following ASICs are highlighted and are described in the following subsections:

- K9+
- Marvin
- PCI-to-EBus/Ethernet controller (Cheerio)
- UPA-to-PCI bridge (PSYCHO+)
- Frame buffer controller (FBC)
- Reset, interrupt, scan, and clock (RISC)

Also included in this section are brief discussions of the SuperIO component.

C.1.15.1 K9+

The K9+ ASIC is a buffered memory crossbar device that acts as the bridge between the six system unit buses. The six system unit buses include two processor buses (144 bits wide), a memory data bus (two buses, each 288 bits wide), a graphics bus, and two I/O buses. The chip is bit-sliced such that 9 parts are required to implement a full connection to the system.

The K9+ ASIC provides the following:

Note – Referred data formats are as follows: a byte is 8 bits, a halfword is 16 bits, a word is 32 bits, and a doubleword is 64 bits.

- Six-port crossbar
- Decoupled memory port; loading and unloading of memory data can take place in parallel with other operations
- Burst transfers operate on a doubleword of data per slice
- A total of eight two-entry first-in-first-out (FIFO) devices for read data storage
- Power-up safe buses (tristated)

C.1.15.2 Marvin

The Marvin ASIC provides system control. It controls the UPA interconnect between the major system unit components and main memory. The Marvin ASIC provides the following:

- Interconnect packet receive
- Memory arbiter
- Non-cached arbiter
- Memory controller
- Snoop interface
- Coherence controller
- S_register dispatcher
- Internet packet send
- Datapatch scheduler
- EBus interface

C.1.15.3 Cheerio

The PCI-to-EBus/Ethernet controller (Cheerio) ASIC performs dual roles: PCI bus-to-Ebus bridging and Ethernet control. The Cheerio ASIC provides the electrical connection between the PCI bus and all other I/O functions.

Cheerio also contains an embedded 10/100Mb Ethernet media-access controller to manage Ethernet transactions and provides the electrical connection to slower on-board functions, such as the Flash PROM, TOD/NVRAM, SuperIO, serial ports, SC/RISC, and the audio module.

Cheerio also contains four dedicated DMA channels; parallel port, audio capture, audio playback, and floppy.

C.1.15.4 PSYCHO+

The UPA-to-PCI bridge (PSYCHO+) ASIC provides an I/O connection between the UPA bus and the two PCI buses. The PSYCHO+ ASIC features include:

- Full master and slave port connection to the high-speed UPA interconnect. The UPA is a split address/data packet-switched bus that has a potential data throughput rate of greater than 1 Gbyte per second. UPA data is ECC protected.
- Two physically separate PCI bus segments with full master and slave support:
 - 66-MHz PCI bus segment (PCI bus A): 3.3-Vdc I/O signaling, 64-bit data bus, compatible with the PCI 66-MHz extensions, support for up to four master devices (at 33 MHz only)
 - 33-MHz PCI bus segment (PCI bus B): 5.0-Vdc I/O signaling, 64-bit data bus, support for up to six master devices

- One 64-bit merge buffer used to perform partial DVMA write in consistent mode. The merge buffer participates in the UPA coherence protocol.
- Two separate 16-entry streaming caches, one for each bus segment, for accelerating some kinds of PCI DVMA activity. Single IOMMU with 16-entry TLB for mapping DVMA addresses for both buses (IOMMU used to translate 32-bit or 64-bit PCI addresses into 41-bit UPA addresses).
- An IOMMU used to translate 32- or 64-bit PCI addresses into 41-bit UPA addresses. The IOMMU is shared between both PCI busses.
- A mondo-vector dispatch unit for delivering interrupt requests to CPU modules, including support for PCI interrupts from up to six slots, as well as interrupts from on-board I/O devices.
- Two 32-bit counters.

C.1.15.5 FBC

The frame buffer controller (FBC) ASIC is the graphics draw ASIC that provides interface between the UPA and the 3DRAM. The FBC ASIC provides 2D and 3D graphics draw acceleration. The FBC resides on the UPA graphics card, not on the Ultra 60 motherboard.

Highlights of the FBC ASIC features include:

- UPA slave device with write-mostly philosophy
- Supports single buffered and DBZ configurations
- Interfaces with 3DRAM to achieve accelerated graphics performance
- Supports frame buffer-to-frame buffer copy
- Supports viewport clipping, picking, and pixel processing
- Supports byte, plane masks, raster operations, blend operations, and conditional writes in 3DRAM
- 83.3-MHz UPA operation and 75-MHz 3DRAM operation
- 3.3-Vdc and 5-Vdc (for RAMDAC ASIC) supply voltage

C.1.15.6 RISC

The reset, interrupt, scan, and clock (RISC) ASIC implements four functions: reset, interrupt, scan, and clock. Generation and stretching of the reset pulse is performed in this ASIC. Interrupt logic concentrates 42 different interrupt sources into a 6-bit code, which communicates with the PSYCHO+ ASIC. It also integrates a JTAG controller.

Highlights of the RISC ASIC features include:

- Determines system clock frequency
- Controls reset generation
- Performs PCI bus and miscellaneous interrupt concentration for PSYCHO+
- Controls flash PROM programming, frequency margining, and lab console operation
- 33-MHz operation
- 3.3-Vdc and 5-Vdc supply voltage

C.1.16 SuperIO

The SuperIO is a commercial, off-the-shelf component that controls the keyboard, diskette, and parallel port interfaces. It contains a DMA-driven diskette controller, two serial port controllers, an IEEE 1284 parallel port interface, and an IDE disk interface (not currently used). The SuperIO drives the various ports directly with some EMI filtering on the keyboard and parallel port signals. Support for mixed voltage modes and power management features for low power operation are also included. Features of the SuperIO include:

- Two independent serial ports used for keyboard and mouse
- N82077 diskette drive interface
- IEEE 1284 parallel port interface

C.2 Power Supply

The system unit uses a 350-watt power supply that operates under the voltage range of 90 to 264 volts root-mean-square (V_{rms}) and a frequency range of 47 to 63 Hz. The maximum input current is 7 amps and the inrush current is limited to 80 peak amps.

The power supply output voltages are listed in TABLE C-8. The power supply continues to regulate all outputs for 20 milliseconds after AC power is removed.

TABLE C-8 Power Supply Output Values

Output	Voltage (Vdc)	Max Current (A)	Regulation Band
1	3.3	60.0	3.23 to 3.43
2	5.0	30.0	4.85 to 5.25

TABLE C-8 Power Supply Output Values (Continued)

Output	Voltage (Vdc)	Max Current (A)	Regulation Band
3	12.0	6.0	11.65 to 12.60
4	-12.0	0.4	-12.60 to -11.40
5	2.5 to 3.5	25.0	+/- 2%

Note – The combined power of output 1 and output 3 must be less than 300 watts.

C.2.1 Control Signals

With the exception of the PowerOn signal, all power supply control signals are at TTL signal levels. TABLE C-9 lists these control signal values.

TABLE C-9 Power Supply Control Signal

Parameter	Min	Max
V _{OH} (high-level output voltage)	2.4 Vdc	
V _{OL} (low-level output voltage)		0.4 Vdc
V _{IH} (high-level input voltage)	2.0 Vdc	
V _{IL} (low-level input voltage)		0.8 Vdc

C.2.1.1 Remote Enable PowerOn and PowerOff

A remote interface can disable the DC outputs with a momentary low signal to the PowerOff input and enable the DC outputs with a momentary low signal to the PowerOn input. Both signals are interfaced to the power supply through the motherboard.

C.2.1.2 On/Off Functionality

The system unit uses a latching relay to remember the state of the power supply. This system uses a momentary On/Off switch and enables other parts of the system (such as software or the keyboard switch) to control the state of power supply.

Turning the System Unit On

The system unit can be turned on in the following ways:

- Keyboard switch
- Set the TOD timer to wake-up at a given time
- Power switch on front of system

Turning the System Unit Off

The system unit can be turned off in the following ways:

- Type `power-off` from shell window (this does a graceful shutdown)
- Halt system and type `power-off` from the OBP
- Activate Energy Star
- Press the keyboard Shift and Power key simultaneously from the OBP
- Press power switch on front of system unit

Note – Energy Star powers off the system only after a period of inactivity and will turn the system back on if set by the user. Energy Star can only be set to be on during a certain time frame, such as from 6 p.m. to 7 a.m. and only comes back on through: TOD, keyboard, or power switch. Energy Star is not a part of the operating system and must be loaded by the user.

C.2.1.3 System Unit Power Budget

The following subsections present the system unit power budgets.

CPU Modules

TABLE C-10 lists the power estimate for the single and dual 300-MHz (3.3-ns) CPU modules.

TABLE C-10 300-MHz (3.3-ns) CPU Module(s) Power Estimate

Description	Qty	2.5-Vdc Core (amps)		3.3-Vdc System (amps)		Watt (max)	
		ea.	sub	ea.	sub	ea.	sub
SRAM (8 data +1 tag)	9			0.909	8.18	3.00	27.00
CPU module core + I/O	1	13.33	13.33			33.33	33.33
CPU module I/O	1			0.27	0.27	0.90	0.90
BDB (@ 2.5 Vdc, EPIC 4)	2	1.04	2.08			2.6	5.20
CPU module	1		15.41		8.45		66.43
CPU module	1		15.41		8.45		66.43

PCI Cards

The PCI card power budget supports a total of 60 watts, which is distributed among four PCI cards in an arbitrary way as long as the total PCI power does not exceed 60 watts. TABLE C-11 lists the power estimate for the 5-Vdc PCI card and TABLE C-12 lists the power estimate for the 3.3-Vdc PCI card.

TABLE C-11 PCI Card (5 Vdc) Power Estimate

Voltage Rail (Vdc)	PCI Cards (Max No.)	Current each (amps)	Current total (amps)	Total Power (W)
5	3	3.0	12.0	
3.3	1	0	0	<= 60
+12	4	0.5	2.0	
-12	4	0.1	0.4	

TABLE C-12 PCI Card (3.3 Vdc) Power Estimate

Voltage Rail (Vdc)	PCI Cards (Max No.)	Current each (amps)	Current total (amps)	Total Power (W)
5	3	0	0	
3.3	1	4.55	18.18	<= 60
+12	4	0.5	2.0	
-12	4	0.1	0.4	

Memory System

TABLE C-13 lists the power estimates for the memory subsystem.

TABLE C-13 Memory Subsystem Power Estimate

Number of DIMMs	WC current total [amps]	Total Power @5 Vdc [W]
16	9.33	46.66

Mass Storage Devices

TABLE C-14 lists power estimates for the storage devices

TABLE C-14 Mass Storage Device Power Estimates

Description	Qty	5-Vdc System (amps)		2.5-Vdc Core (amps)		3.3-Vdc System (amps)		12-Vdc System (amps)		-12Vdc System [amps]		Watt (max)	Watt (max)
		ea.	sub	ea.	sub	ea.	sub	ea.	sub	ea.	sub	ea.	sub
Motherboard 16-DIMM no CPU module	1	9.9	9.9			4.25	4.25	0.23	0.23			66.2	66.2
CPU module	1			15.4	15.4	9.5	9.5					66.4	66.4
Diskette drive	1	0.3	0.3									1.20	1.2
Hard drive, 1-inch 7200 rpm	0	1.2	0.0					1.2	0			15.0	0.0

TABLE C-14 Mass Storage Device Power Estimates (Continued)

Description	Qty	5-Vdc System (amps)		2.5-Vdc Core (amps)		3.3-Vdc System (amps)		12-Vdc System (amps)		-12Vdc System [amps]		Watt (max)	Watt (max)
Hard drive, 1.6-inch 7200 rpm	2	1.5	3.0					1.65	3.3			20.0	40.0
Mammoth tape	1	2.4	2.4					0.7	0.7			17.0	17.0
DBZ graphics	0	0.4	0			5	0	0.1	0			20	0.0
PCI (5 Vdc)	4	3	12					0.5	2.0	0.1	0.4	15	60.0
PCI (3.3 Vdc)						4.6	18.2						
MII	1	0.8	0.8									4	4.0
Fan	2							0.4	0.8			4.8	9.6
Total		20.0	28.4	15.4	15.4	26.7	32.0	4.9	7.0	0.1	0.4	185	264

C.2.2 Built-In Speaker

The system unit contains a cost-effective speaker. The speaker provides audio functionality in the absence of external speakers. Audio from all sources is available. TABLE C-15 lists the built-in speaker specifications.

TABLE C-15 Built-In Speaker Specifications

Speaker	Specifications
Power output	1.5W average, 3W peak
Distortion	0.02%, typical at 1 kHz
Impedance	16Ω +/- 20%
Frequency response	150 Hz to 17 kHz +/- 0.5 dB

C.2.3 Standard System Facilities

In addition to the previously listed features, the system unit provides the following:

- TOD/NVRAM for clock and identification functions
- Flash PROM for operating system initialization. The flash PROM is re-programmable through UNIX and OBP utilities.
- Single LED for status. If LED is lighted, the system unit has power and some functional intelligence through OBP.

C.3 Motherboard

FIGURE C-12 illustrates a block diagram of the system unit motherboard.

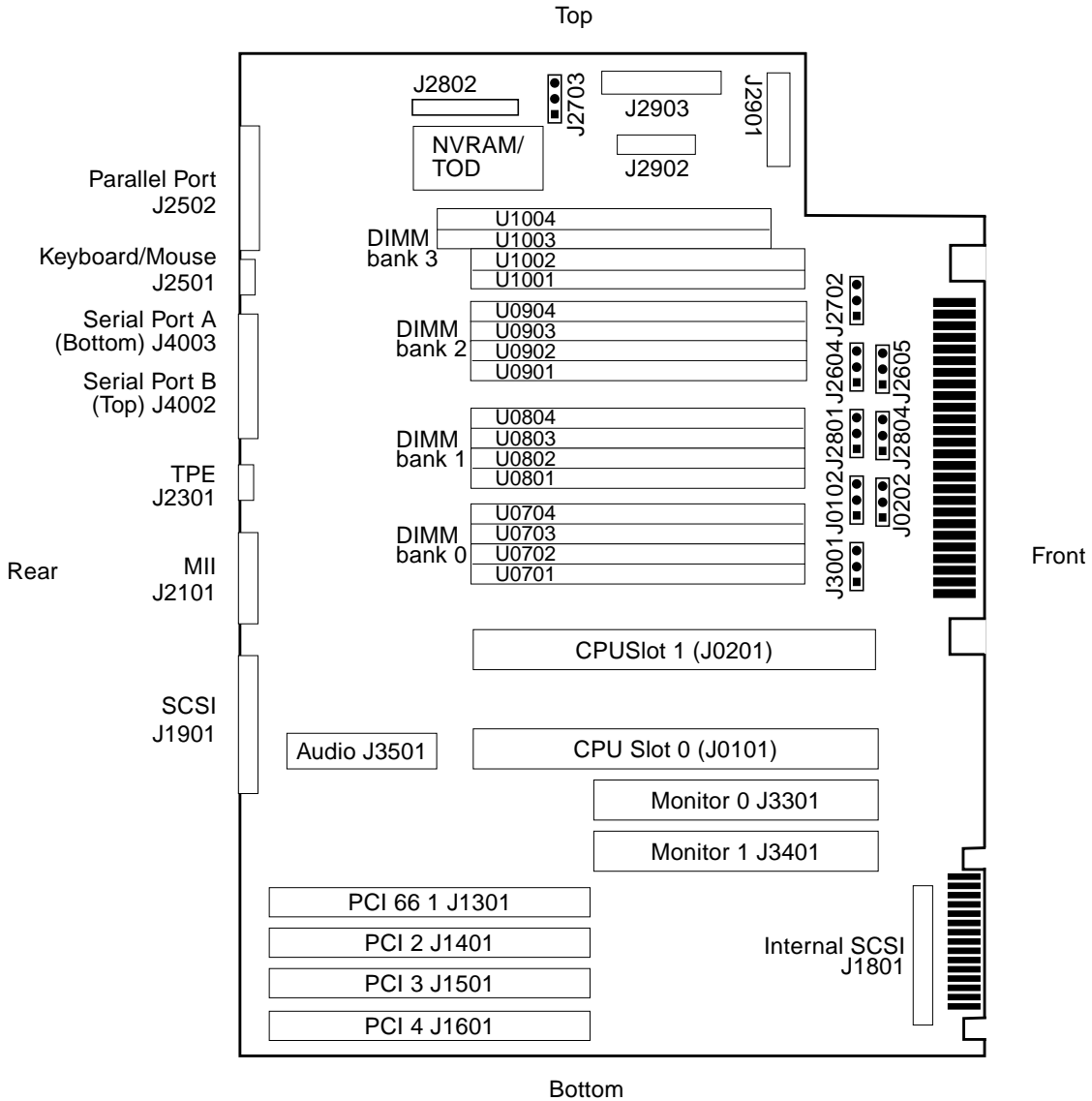

J2703=FPPROM R/W, J2605 + J2604=RS423/232,
 J3001=UPA Clk /2 /3, J2804=FPPROM Boot Hi-Lo.

FIGURE C-12 System Unit Motherboard Functional Block Diagram

C.4 Jumper Descriptions

Jumper configurations can be changed by setting jumper switches on the motherboard. The motherboard's jumpers are preset at the factory.

A jumper switch is *closed* (sometimes referred to as shorted) with the plastic cap inserted over two pins of the jumper. A jumper is *open* with the plastic cap inserted over one or no pin(s) of the jumper. FIGURE C-13 shows the different jumper settings that are used on the motherboard.

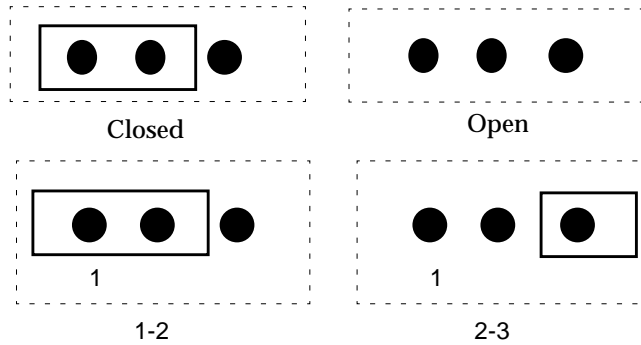

FIGURE C-13 Selected Jumper Settings

Jumper descriptions include brief overviews of serial port jumpers, flash PROM jumpers, and additional system board jumper and connector blocks.

Jumpers are identified on the system board by J designations. Jumper pins are located immediately adjacent to the J designator. Pin 1 is marked with an asterisk in any of the positions shown (FIGURE C-14). Ensure that the serial port jumpers are set correctly.

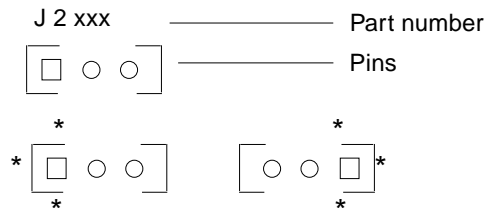

FIGURE C-14 Identifying Jumper Pins

C.4.1 Serial Port Jumpers

Serial port jumpers J2604 and J2605 can be set to either RS-423 or RS-232 serial interface. The jumpers are preset for RS-423. RS-232 is required for digital telecommunication within the European Community. TABLE C-16 identifies serial port jumper settings. If the system is being connected to a public X.25 network, the serial port mode jumper setting may need to change from RS-423 to RS-232 mode.

To change the serial port mode jumper setting:

- 1. Power off the system unit.**

See Section 6.2, “Powering Off the System Unit” on page 6-3.

- 2. Remove the side access cover.**

See Section 7.1, “Removing the Side Access Cover” on page 7-2.



Caution – Use proper ESD grounding techniques when handling components. Wear an antistatic wriststrap and use an ESD-protected mat. Store ESD-sensitive components in antistatic bags before placing them on any surface.

- 3. Attach the wrist strap.**

See Section 7.2, “Attaching the Wrist Strap” on page 7-3.

- 4. Locate the jumpers on the system board. Change the J2604 and J2605 jumper selection.**

See TABLE C-16.

- 5. Detach the wrist strap.**

- 6. Replace the side access cover.**

See Section 7.3, “Replacing the Side Access Cover” on page 7-4.

- 7. Power on the system unit.**

See Section 6.1, “Powering On the System Unit” on page 6-2.

TABLE C-16 Serial Port Jumper Settings

Jumper	Pins 1 + 2 Select	Pins 2 + 3 Select	Default Jumper on Pins
J2604	RS-232	RS-423	2 + 3
J2605	RS-232	RS-423	2 + 3

C.4.2 Flash PROM Jumpers

Flash PROM jumpers J2703 and J2704 are for reprogramming specific code blocks and remote programming of the flash PROM. TABLE C-17 identifies the flash PROM jumper settings. The default shunt setting of J2703 is on pins 1 and 2. Placing the shunt on pins 2 and 3 enables reprogramming of the flash PROM.

TABLE C-17 Flash PROM Jumper Settings

Jumper	Pins 1 + 2 Select	Pins 2 +3 Select	Default Jumper on Pins	Signal Controlled
J2703	Write protect	Write Enable	1 + 2	FLASH PROM PROG ENABLE
J2704	High half booting	Normal Booting	2 + 3	XOR LOGIC SET

C.5 Enclosure

The system unit uses an enclosure that reflects style, ergonomics, serviceability, functionality, versatility, and quality. Physical orientation allows for a rack-mount, desktop, or under desk installation. The enclosure design complies with all necessary environmental and regulatory specifications.

C.5.1 Enclosure Basics

Overall dimensions of the enclosure are 17.70 inches (45.00 cm) x 7.50 inches (19.00 cm) x 17.60 inches (49.60 cm). The enclosure houses:

- One 3.5-inch diskette drive
- One 1.6-inch CD-ROM drive
- One spare 3.5-inch device slot

Note – The CD-ROM drive slot is used for either the CD-ROM drive or an X-option-selected tape drive.

- Two 1-inch single-connector 3.5-inch disk drives
- Two plug-in UltraSPARC modules

- Sixteen DIMMs (grouped in banks of four)
- Four PCI slots
- One UPA64S module

C.5.2 Enclosure Features

Enclosure features include:

- Good access for internal upgrades and service
- Optimized system board layout
- Graphics expansion module (UPA64S connector)
- Processor placed on plug-in module. Allows for upgrades
- All standard connectors and no splitter cables on rear panel

C.6 Environmental Compliance

The system unit meets or exceeds the specifications defined by the “Controlled Office” classification of the 990-1146-03, Rev A document.

C.7 Agency Compliance

The system unit complies with international and domestic regulatory requirements for safety, ergonomics, EMI, immunity, electrical, and telecommunication.

C.8 Energy Star Software Support

Energy Star® power management software is supported on the Ultra 60 system when used with version 2.6 and later of the Solaris operating environment.

Glossary

- address** A unique location within computer or peripheral memory. Reference made to an address is usually for retrieving or storing data.
- ASIC** Application-specific integrated circuit.
- ASP** Authorized service provider.
- boot** A term used to identify the process of reading initial software into the computer.
- boot PROM** In Sun workstations, contains the PROM monitor program, a command interpreter used for booting, resetting, low-level configuration, and simple test procedures.
- CDE** Common Desktop Environment.
- CD-ROM** Compact disk-read only memory.
- DBZ** Double buffer with Z.
- DCE** Data communication equipment. An external modem.
- default** A preset value that is assumed to be correct unless changed by the user.
- DIMM** Dual in-line memory module. A small printed circuit card that contains dynamic random-access memory chips.
- DMA** Direct memory address.
- dpi** Dots per inch.
- DPS** Data path scheduler. Controls all data flow that coordinates the activity of the BMX chips.
- DRAM** Dynamic random-access memory. A read/write dynamic memory in which the data can be read or written in approximately the same amount of time for any memory location.

DTAG	Dual tag or data tag.
DTE	Data terminal equipment.
ECP	Extended capability port. An IEEE.1284 standard.
EMI	Electro-magnetic interference. Electrical characteristic that directly or indirectly contributes to a degradation in performance of an electronic system.
Ethernet	A type of network hardware that provides communication between systems connected directly together by transceiver taps, transceiver cables, and various cable types such as coaxial, twisted-pair, and fiber-optic.
FBC	Frame buffer controller. An ASIC responsible for the interface between the UPA and the 3DRAM. Also controls graphic draw acceleration.
FIFO	First-in first-out.
flash PROM	Flash programmable read-only memory.
Gbyte	Gigabyte.
GUI	Graphical user interface.
IDC	Insulation displacement connector.
I/O	Input/output.
Kbyte	Kilobyte.
LED	Light-emitting diode.
Mbyte	Megabyte.
MBps	Megabyte per second.
Mbps	Megabit per second.
MHz	Megahertz.
MII	Media independent interface.
ns	Nanosecond.
NVRAM	Non-volatile random-access memory. Stores system variables used by the boot PROM. Contains the system hostID number and Ethernet address.
OBP	OpenBoot PROM. A routine that tests the network controller, diskette drive system, memory, cache, system clock, network monitoring, and control registers.

PCI	Peripheral component interconnect. A high-performance 32- or 64-bit-wide bus with multiplexed address and data lines.
PCIO	PCI-to-EBus/Ethernet controller. An ASIC that bridges the PCI bus to the EBus, enabling communication between the PCI bus and all miscellaneous I/O functions, as well as the connection to slower on-board functions.
PCMCIA	Personal computer memory card international association.
PID	Process ID.
POR	Power-on reset.
POST	Power-on self-test. A series of tests that verify system board components are operating properly. Initialized at system power-on or when the system is rebooted.
RAMDAC	RAM digital-to-analog converter. An ASIC responsible for direct interface to 3DRAM. Also provides on-board phase-lock loop (PLL) and clock generator circuitry for the pixel clock.
RC	Resistive-capacitive.
RISC	Reset, interrupt, scan, and clock. An ASIC responsible for reset, interrupt, scan, and clock.
RMA	Removable media assembly. Can include a CD-ROM drive or 4-mm, 8-mm, a diskette drive, and any other 3.5-inch device, such as a second diskette drive or a peripheral component interconnect (PCI) device.
SB	Single buffer.
SCSI	Small computer system interface.
SC_UP+	System controller uniprocessor plus. An ASIC that regulates the flow of requests and data throughout the system unit.
STP	Shielded twisted-pair.
SunVTS	A diagnostic application designed to test hardware.
TPE	Twisted-pair Ethernet.
TOD	Time of day. A timekeeping intergrated circuit.
TTL	Transistor-transistor logic.
U2P	UPA-to-PCI. An ASIC that controls the PCI buses. It forms the bridge from the UPA bus to the PCI buses.

UPA	UltraSPARC port architecture. Provides processor-to-memory interconnection.
UPA AD 0	UPA address bus 0. Provides data interface between CPU module 0 and the QSC ASIC.
UPA AD 1	UPA address bus 1. Provides data interface between CPU module 1 and the QSC ASIC. Supports slave UPA connection to the expansion slot for graphics capability.
UPA AD 2	UPA address bus 2. Provides data interface between QSC ASIC and the U2P ASIC.
UPA AD 3	UPA address bus 3. Provides data interface between QSC ASIC and the UPA graphics.
UPA DATA 0	UPA data bus 0. Provides 144-bit-wide data bus between the XB9+ ASIC and CPU module 0.
UPA DATA 1	UPA data bus 1. Provides 144-bit-wide data bus between the XB9+ ASIC and the UPA graphics.
UPA DATA 2	UPA data bus 2. Provides 64-bit-wide data bus between the XB9+ ASIC and CPU module 0.
UPA DATA 3	UPA data bus 3. Provides 72-bit-wide data bus between the XB9+ ASIC and the U2P ASIC.
UTP	Unshielded twisted-pair.
VIS	Visual instruction set.
Vrms	Volts root-mean-square.

Index

A

- agency compliance, C-48
- all above
 - output message, 4-23
- ASIC
 - FBC, C-35
 - PCIO, C-7, C-34
 - QSC, C-34
 - RISC, C-35
 - XB9+, C-33
- ASICs, C-33
- attaching wrist strap to chassis, 7-4, 8-22, 8-23, 8-24
- audio
 - card
 - connector, C-28
 - features, C-28
 - functional block diagram, C-29
 - connector, B-10
 - line assignments, B-11
 - pin configuration, B-11
 - module
 - removing, 10-16
 - replacing, 10-18
 - output message, 4-22
- automatic negotiation, C-25

B

- baud rate, verifying, 3-4
- built-in speaker, C-42
- bypassing POST, 3-21

C

- CD-ROM drive, C-16
 - removing, 9-6
 - replacing, 9-8
- CD-ROM drive failure, 4-3
- chassis foot
 - removing, 8-16, 8-17
 - replacing, 8-17, 8-18
- commands, keyboard control, 3-22
- compliance
 - agency, C-48
 - environmental, C-48
- components, system unit, 1-5
- connector
 - audio, B-10
 - keyboard/mouse, B-2
 - MII, B-14
 - parallel port, B-11
 - pin assignments
 - keyboard/mouse, B-2
 - MII, B-14
 - parallel port, B-12

- serial port A, B-3
- serial port B, B-3
- TPE, B-6
- UltraSCSI, B-7
- UPA graphics card, B-16
- pin configuration
 - audio, B-11
 - keyboard/mouse, B-2
 - MII, B-14
 - parallel port, B-12
 - TPE, B-6
 - UltraSCSI, B-7
 - UPA graphics card, B-16
- serial port A, B-3
- serial port B, B-3
- TPE, B-5
- UltraSCSI, B-6
- UPA graphics card, B-16
- cover, side access
 - removing, 7-2
 - replacing, 7-4
- CPU
 - fan assembly
 - removing, 8-36
 - replacing, 8-37
 - module
 - removing, 10-2
 - replacing, 10-4

D

- description
 - functional, C-1
 - product, 1-1
 - signal, B-1
 - SunVTS, 2-1
- desktop workstation, Ultra 60 series, 1-2
- diag-level
 - switch settings, 3-2
 - variable
 - set to max, 3-7
 - set to min, 3-14
- diagnostics, OBP on-board, 4-8
- DIMM

- bank location, 10-13
- bank-to-U-number mapping, C-13
- failure, 4-7
- physical address mapping
 - IL = 0, C-14
- physical memory address, 4-8
- removing, 10-13
- replacing, 10-15
- row location, 10-13
- socket pair location, 10-13
- disk drive failure, 4-3
- diskette drive, C-16
 - cable assembly
 - removing, 8-12
 - replacing, 8-13
 - connectors, C-16
 - functions, C-17
 - removing, 9-8
 - replacing, 9-9
 - signals, C-17
 - SuperIO interface, C-16
 - supported features, C-16
- diskette port, C-19, C-20
 - functional block diagram, C-20
- document organization, xvii

E

- EBus DMA/TCR registers output message, 4-16
- EBus2, C-7
- electrical specifications, A-2
- EMI filler panel
 - removing, 8-14
 - replacing, 8-15
- enclosure
 - basics, C-47
 - features, C-48
- environmental
 - compliance, C-48
 - requirements, A-3

error reporting, POST, 3-18

Ethernet, C-24

 automatic negotiation, C-25

 connectors, C-26

 external cables, C-26

 MII port timing, C-26

 MII power, C-26

 output message, 4-17

 transceivers, external, C-26

external

 cables, C-26

 cables, SCSI, C-31

F

failure

 CD-ROM drive, 4-3

 DIMM, 4-7

 disk drive, 4-3

 power-on, 4-2

 video output, 4-3

FBC ASIC, C-35

flash PROM

 jumper settings, C-47

 jumpers, C-47

floppy output message, 4-18

foot, chassis, 8-16

front view, system unit, 1-4

functional

 block diagram

 audio card, C-29

 diskette port, C-20

 keyboard/mouse port, C-20

 memory module, C-11

 memory system, C-10

 parallel port, C-20

 SCSI subassembly, C-32

 system unit, C-3

 system unit motherboard, C-44

 UPA

 address bus, C-5

 data bus, C-5

 description, C-1

G

graphics, C-14

 card

 features, C-15

 performance, C-15

H

hard drive

 removing, 9-2

 replacing, 9-3

 supported, C-18

host adapter, C-30

how this book is organized, xvii

I

I/O devices, 1-3

 supported, 1-3

identification, internal drives, 4-4

identifying jumper pins, 10-24, C-45

illustrated parts list, 11-1

imaging, C-14

initializing POST, 3-5

internal

 drives identification, 4-4

 SCSI sub-assembly, C-32

J

jumper

 settings

 flash PROM, C-47

 serial port, 10-23, C-46

 settings, selected, C-45

jumper pins

- identifying, C-45
- jumpers
 - flash PROM, C-47
 - serial port, C-46

K

- keyboard
 - LED patterns, 3-21
 - output message, 4-17
 - Sun type-5, 6-3, 8-35
- keyboard/mouse
 - connector, B-2
 - pin assignments, B-2
 - pin configuration, B-2
 - port, C-19
 - functional block diagram, C-20

L

- LEDs, 3-5
 - keyboard, 3-22
 - patterns, keyboard, 3-21
 - system, 3-22
- line assignments, audio connector, B-11
- lock block location, 7-2

M

- major subassemblies, 8-1
- maximum level of POST, 3-6
- memory
 - module functional block diagram, C-11
 - system, C-9
 - functional block diagram, C-10
 - timing, C-14
- MII
 - connector, B-14
 - pin assignments, B-14
 - pin configuration, B-14
 - port timing, C-26

- port timing model, C-27
- power, C-26
- minimum level of POST, 3-6
- motherboard
 - component replacement, 10-1
 - initializing POST, 3-23
 - removing, 10-20
 - replacement, 10-1
 - replacing, 10-23
- mouse output message, 4-18

N

- NVRAM
 - output message, 4-22
- NVRAM/TOD
 - removing, 10-5
 - replacing, 10-6

O

- OBDDiag menu, 4-14
- OBDDiags, 4-13
- OBP on-board diagnostics, 4-8
 - probe-SCSI, 4-10
 - probe-SCSI-all, 4-10
 - selected tests, 4-12
 - watch-clock, 4-9
 - watch-net, 4-9
 - watch-net-all, 4-9
- on/off functionality, C-37
- OpenBoot diagnostics, 4-13
- operation
 - SunVTS, 2-2
- other RMA storage device X-options, C-19
- output message
 - all above, 4-23
 - audio, 4-22
 - EBus DMA/TCR registers, 4-16

- Ethernet, 4-17
- floppy, 4-18
- keyboard, 4-17
- mouse, 4-18
- NVRAM, 4-22
- parallel port, 4-19
- PCI/PCIO, 4-15
- probe-scsi, 4-10
- probe-scsi all, 4-10
- SCSI, 4-23
- serial port A, 4-19
- serial port A with TIP line, 4-20
- serial port B, 4-21
- test, 4-11
- watch-clock, 4-9
- watch-net, 4-9
- watch-net all, 4-10
- overview
 - POST, 3-2
 - SunVTS, 2-1

P

- parallel port, C-19, C-21
 - cables, C-21
 - connector, B-11
 - pin assignments, B-12
 - pin configuration, B-12
 - electrical characteristics, C-21
 - functional block diagram, C-20
 - output message, 4-19
- parts list, illustrated, 11-1
- PCI
 - card
 - removing, 10-7
 - replacing, 10-9
 - fan assembly
 - removing, 8-5, 8-6, 8-25
 - replacing, 8-6
- PCIO ASIC, C-7, C-34
- peripheral

- component interconnect bus, C-6
- power cable assembly
 - removing, 8-11
 - replacing, 8-12
- peripherals, C-15
 - CD-ROM drive, C-16
 - diskette drive, C-16
- physical specifications, A-2
 - system unit, A-2
- ported, C-16
- POST
 - bypassing, 3-21
 - error reporting, 3-18
 - initializing, 3-5
 - maximum level, 3-6
 - minimum level, 3-6
 - motherboard, initializing, 3-23
 - overview, 3-2
 - progress reporting, 3-18
- power supply
 - connector J2901, 4-6
 - pin description, 4-6
 - connector J2902, 4-6
 - pin description, 4-6
 - connector J2903, 4-7
 - pin description, 4-7
 - control signals, C-37
 - on/off functionality, C-37
 - output values, C-36
 - remote enable
 - PowerOff, C-37
 - PowerOn, C-37
 - removing, 8-2
 - replacing, 8-3
 - test, 4-5
- powering
 - off the system unit, 6-3
 - on the system unit, 6-2
- power-on
 - failure, 4-2
 - self-test, 3-1

- pre-POST preparation, 3-2
 - setting up tip connection, 3-3
 - verifying baud rate, 3-4
- probe
 - SCSI, 4-10
 - SCSI-all, 4-10
- probe scsi all output message, 4-10
- probe scsi output message, 4-10
- procedures
 - troubleshooting, 4-1
- processor, UltraSPARC II, C-8
- product
 - description, 1-1
 - specifications, A-1
- progress reporting, POST, 3-18

Q

- QSC ASIC, C-34

R

- rear view
 - system unit, 1-5
- removing
 - audio module, 10-16
 - cable assembly
 - diskette drive, 8-12
 - peripheral power, 8-11
 - chassis foot, 8-16, 8-17
 - CPU fan assembly, 8-36
 - CPU module, 10-2
 - DIMM, 10-13
 - diskette drive, 9-8
 - EMI filler panel, 8-14
 - hard drive, 8-26, 9-2, 9-3
 - motherboard, 10-20
 - NVRAM/TOD, 10-5
 - PCI card, 10-7
 - PCI fan assembly, 8-5, 8-6, 8-25

- power supply, 8-2
- RMA, 9-4
- SCSI drive bay, 8-7
- shroud assembly, 8-38
- side access cover, 7-2
- UPA graphics card, 10-10
- x-option tape drive, 9-6
- replaceable components
 - system unit, 1-6
- replacing
 - audio module, 10-18
 - cable assembly
 - diskette drive, 8-13
 - peripheral power, 8-12
 - CD-ROM drive, 9-8
 - chassis foot, 8-17, 8-18
 - CPU fan assembly, 8-37
 - CPU module, 10-4
 - DIMM, 10-15
 - diskette drive, 9-9
 - EMI filler panel, 8-15
 - hard drive, 8-26, 9-3
 - motherboard, 10-23
 - NVRAM/TOD, 10-6
 - PCI card, 10-9
 - PCI fan assembly, 8-6
 - power supply, 8-3
 - RMA, 9-9
 - SCSI drive bay, 8-9
 - shroud assembly, 8-39
 - side access cover, 7-4
 - UPA graphics card, 10-11
 - x-option tape drive, 9-8
- requirements, environmental, A-3
- RISC ASIC, C-35
- RMA
 - removing, 9-4
 - replacing, 9-9

S

- safety requirements, 5-2
- SCSI, C-30
 - drive bay
 - removing, 8-7
 - replacing, 8-9
 - external cables, C-31
 - host adapter, C-30
 - internal SCSI sub-assembly, C-32
 - output message, 4-23
 - subassembly functional block diagram, C-32
 - supported target devices, C-31
- selected jumper settings, C-45
- serial
 - port, C-22
 - asynchronous rates, C-24
 - cable length, C-24
 - components, C-22
 - EIA levels, C-23
 - functions, C-23
 - jumper settings, 10-23, C-46
 - jumpers, C-46
 - slew rate, C-24
 - synchronous rates, C-24
 - port A
 - connector, B-3
 - pin assignments, B-3
 - output message, 4-19
 - output message with TIP line, 4-20
 - port B
 - connector, B-3
 - pin assignments, B-3
 - output message, 4-21
- setting up tip connection, 3-3
- shell prompts, xix
- shroud assembly
 - removing, 8-38
 - replacing, 8-39
- side access cover
 - removing, 7-2
 - replacing, 7-4
- signal descriptions, B-1
- speaker, built-in, C-42
- specifications
 - electrical, A-2
 - physical, A-2
 - product, A-1
- standard system facilities, C-43
- storage devices, 9-1
- Sun
 - Type-5 keyboard, 3-5
 - type-5 keyboard, 6-3, 8-35
 - Type-5 keyboard LEDs, 3-5
- SunVTS
 - description, 2-1
 - documentation, 2-2
 - operation, 2-2
 - overview, 2-1
- SuperIO, C-36
 - diskette drive interface, C-16
- supported
 - hard drives, C-18
 - I/O devices, 1-3
 - target devices, C-31
- switch
 - settings, diag-level, 3-2
- symbols, 5-2
- System, C-5
- system
 - facilities, standard, C-43
 - power-on (front panel), 6-2, 8-35
- system controller, C-5
- system unit, C-2
 - components, 1-5
 - exploded view, 11-2
 - front view, 1-4
 - functional block diagram, C-3
 - motherboard functional block diagram, C-44
 - physical specifications, A-2
 - power budget, C-39
 - 300-MHz CPU module, C-39
 - mass storage devices, C-41
 - memory system, C-41

- PCI cards, C-40
- power-off (front panel), 6-4, 8-20
- rear view, 1-5
- replaceable components, 1-6, 11-3

T

- test power supply, 4-5
- tip connection, setting up, 3-3
- tools required, 5-4
- TPE
 - connector
 - pin assignments, B-6
 - pin configuration, B-6
- TPE connector, B-5
- troubleshooting procedures, 4-1
- typical error code failure message, 3-19
- typographic conventions, xix

U

- Ultra 60 series desktop workstation, 1-2
- UltraSCSI
 - connector, B-6
 - pin assignments, B-7
 - pin configuration, B-7
- UltraSPARC II processor, C-8
- UNIX commands, xviii
- UPA, C-4
 - address bus functional block diagram, C-5
 - data bus functional block diagram, C-5
 - port identification assignments, C-4
- UPA graphics card, 4-12
 - connector, B-16
 - pin assignments, B-16
 - pin configuration, B-16
 - removing, 10-10
 - replacing, 10-11

V

- verifying baud rate, 3-4
- video output failure, 4-3

W

- watch
 - clock, 4-9
 - clock output message, 4-9
 - net all output message, 4-10
 - net output message, 4-9
- wrist strap, attaching to chassis, 7-4, 8-22, 8-23, 8-24

X

- XB9+ ASIC, C-33
- x-option tape drive
 - removing
 - CD-ROM drive, 9-6
 - replacing, 9-8